

MEETING NOTICE

NOTICE IS HEREBY GIVEN that the Regular Meeting of the President and Board of Trustees of the Village of Tinley Park, Cook and Will Counties, Illinois will be held on Tuesday, April 5, 2022, beginning at 6:30 PM in the Council Chambers at the Village Hall of Tinley Park, 16250 South Oak Park Avenue, Tinley Park, Illinois.

6:30 PM CALL TO ORDER
 PLEDGE OF ALLEGIANCE
 ROLL CALL

ITEM #1

SUBJECT: CONSIDER APPROVAL OF AGENDA

ACTION: Discussion - **Consider approval of agenda as written or amended.**

COMMENTS: _____

ITEM #2

SUBJECT: CONSIDER APPROVAL OF MINUTES OF THE SPECIAL
 VILLAGE BOARD MEETING HELD ON MARCH 15, 2022.

ACTION: Discussion: **Consider approval of minutes as written or amended.**

COMMENTS: _____

ITEM #3

SUBJECT: CONSIDER PROCLAIMING APRIL 10 TO APRIL 16, 2022, AS NATIONAL
 PUBLIC SAFETY TELECOMMUNICATORS WEEK IN THE VILLAGE OF
 TINLEY PARK – **President Glotz**

ACTION: Discussion: Whether it’s a fire, robbery, medical or another personal
 emergency, there’s always someone to answer our call for help in our moment
 of need. The Tinley Park 911 Center is staffed 24/7, 365 days a year, and these
 professionals, also known as Telecommunicators, are prepared to answer your
 emergency. The Village appreciates all the dedication and hard work the
 Telecommunicators do every day. **Consider proclaiming April 10th through
 April 16th as National Telecommunicator Week.**

COMMENTS: _____

ITEM #4

SUBJECT: RECEIVE PRESENTATIONS OF THE TINLEY PARK BUSINESS SPOTLIGHT - THE BARKETPLACE AND VCI MED SPA - **President Glotz and Clerk O'Connor**

ACTION: Discussion:

1. The Barketplace is an independently-owned pet supply store on Oak Park Avenue that specializes in natural pet food, pet treats, and gifts for pet parents. We are pleased to welcome Amanda Daly, owner of The Barketplace.
2. VCI Med Spa offers a full array of rejuvenation, cosmetic enhancement, and vein treatment services by meticulously-trained practitioners with medical backgrounds. Please join me in welcoming Angela Arrigo-Dunlap, RN, BSN, Director of VCI Med Spa.

COMMENTS: _____

ITEM #5

SUBJECT: CONSIDER APPOINTING ORLANDO PIMENTEL TO THE POSITION OF 911 DISPATCHER - **President Glotz**

ACTION: Discussion: Orlando has over 26 years of experience in dispatching emergency and non-emergency services working for another municipality for 20 years and then transitioning to a centralized 911 call center remaining dedicated to serving the community. He has been LEADS certified and is a former APCO Certified Trainer. **Consider appointing Orlando Pimentel to the position of 911 Dispatcher effective April 6, 2022.**

COMMENTS: _____

ITEM #6

SUBJECT: CONSIDER APPOINTING SANDRA YOUNG TO THE POSITION OF APPLICATION SUPPORT ANALYST - **President Glotz**

ACTION: Discussion: Sandra has over 24 years of experience in Information Technology holding various front-end user and back-end development roles supporting the technology needs for a large organization. She is skilled in a broad range of project management, database and systems administration, software development, and help desk support functions. She has multiple years of experience interacting with project stakeholders, training new users, supporting internal end-users, data extraction, and with vendor management. Sandra holds a Bachelor of Science in Computer Science. **Consider appointing Sandra Young to the position of Application Support Analyst effective May 2, 2022.**

COMMENTS: _____

ITEM #7

SUBJECT: CONSIDER APPOINTING AMANDA GAUS TO THE POSITION OF SPECIAL EVENTS SPECIALIST - **President Glotz**

ACTION: Discussion: Amanda has over 15 years of experience in marketing, programming, and special events management working in various corporate marketing and recreation management roles. She has managed numerous programs and facility projects as well as coordinated large special events. She has found innovative ways to create success in event planning, facility management, recreational programming, marketing, and aquatics. Amanda holds a Bachelor of Arts degree in Business Administration with a concentration in Marketing and Management. **Consider appointing Amanda Gaus to the position of Special Events Specialist effective April 18, 2022.**

COMMENTS: _____

ITEM #8

SUBJECT: CONSIDER APPOINTING PASTOR RICCI DEL PRIORE TO THE POSITION OF FIRE DEPARTMENT CHAPLAIN – **President Glotz**

ACTION: Discussion: Ricci Del Priore is a Pastor for Parkview Christian Church, and has nearly 11 years of experience. He has been the campus pastor at the Parkview Christian Church New Lenox location since their opening in 2016. Pastor Ricci is very passionate about helping first responders, and has graciously volunteered his time to provide spiritual support and encouragement to the members of the Tinley Park Fire Department. **Consider appointing Pastor Ricci Del Priore to the position of Fire Department Chaplain effective April 6, 2022.**

COMMENTS: _____

ITEM #9

SUBJECT: CONSIDER APPOINTING TIMOTHY O’HAGAN TO THE POSITION OF ASSISTANT FIRE CHIEF - **President Glotz**

ACTION: Discussion: Tim began his fire service career as a volunteer firefighter in 1983 for the Village of Tinley Park and has continued to serve the community and Fire Department for over 38 years. With his dedication to the department, he has served as President of the Firefighters Association for over 25 years and more recently assisted with the personnel division’s key initiatives.

Tim has achieved numerous certifications, including Advanced Fire Officer, and holds an Associate Degree in Business Science. In addition, Tim brings his expansive fire service experience into the classroom for firefighters across the State of Illinois as an instructor with the Illinois Fire Service Institute. Tim also volunteers with the Illinois Firefighter Peer Support Team, helping support fellow firefighters’ mental health. Tim enjoys being involved in the community and fire department events, including the parade and annual charity golf outing.

Consider appointing Timothy O’Hagan to the position of Assistant Fire Chief effective April 6, 2022.

COMMENTS: _____

ITEM #10

SUBJECT: CONSIDER APPOINTING WILLIAM MURRAY TO THE POSITION OF ASSISTANT FIRE CHIEF - **President Glotz**

ACTION: Discussion: Bill joined the Tinley Park Fire Department in 2001 and over the past 20 years rose through the ranks serving most recently as Captain of Station 48. He also works full-time as the Assistant Chief of Operations for the Romeoville Fire Department.

Bill grew up in Tinley Park and is a graduate of Andrew High School and a former Tinley Park Bulldog. He received his Associate Degree from Moraine Valley Community College and is now in his final year at Southern Illinois University where he is pursuing his bachelor degree in Fire Service Administration. In addition, he has achieved the highest level of executive leadership education in the State of Illinois and holds the Chief Fire Officer Certification from the Office of the State Fire Marshal. Additionally, he currently teaches classes for the Illinois Fire Service Institute as well as the Romeoville Fire Academy and is a licensed Drone Operator through the Federal Aviation Association and participates in missing persons searches. **Consider appointing William Murray to the position of Assistant Fire Chief effective April 6, 2022.**

COMMENTS: _____

ITEM #11

SUBJECT: CONDUCT A SWEARING IN CEREMONY FOR ASSISTANT FIRE CHIEF TIMOTHY O'HAGAN AND ASSISTANT FIRE CHIEF WILLIAM MURRAY
- **Trustee Brennan**

ACTION: Discussion: Clerk O'Connor will swear-in the Assistant Fire Chiefs. **No specific action is required.**

COMMENTS: _____

ITEM #12

SUBJECT: CONSIDER APPROVAL OF THE FOLLOWING CONSENT AGENDA ITEMS:

- A. CONSIDER ADOPTING RESOLUTION 2022-R-025 AUTHORIZING AN AGREEMENT WITH BETTENHAUSEN & ASSOCIATES, LLC FOR AN AMOUNT NOT TO EXCEED \$90,000.
- B. CONSIDER APPROVAL OF FUNDING FOR THE VisitTinleyPark.com TOURISM WEBSITE.
- C. CONSIDER ADOPTING RESOLUTION 2022-R-026 APPROVING AN INTERGOVERNMENTAL AGREEMENT BETWEEN THE VILLAGE OF TINLEY PARK AND KIRBY SCHOOL DISTRICT 140 FOR SCHOOL SAFETY LIGHTS AT 80TH AVENUE & 167TH STREET AT AN ESTIMATED COST TO THE VILLAGE OF \$20,000.
- D. CONSIDER ADOPTING RESOLUTION 2022-R-027 APPROVING A CONTRACT RENEWAL BETWEEN THE VILLAGE OF TINLEY PARK AND AQUAMIST PLUMBING & LAWN SPRINKLING, INC. FOR 2022 IRRIGATION MAINTENANCE IN THE AMOUNT OF \$41,339.41.
- E. CONSIDER PAYMENT OF IMPACT FEES THROUGH FEBRUARY 2022 IN THE AMOUNT OF \$1,300 TO CONSOLIDATED HIGH SCHOOL DISTRICT 230.
- F. CONSIDER REQUEST FROM HARALD VIKING LODGE #13 TO CONDUCT A QUEEN OF HEARTS RAFFLE BEGINNING APRIL 6, 2022, WITH THE WINNER BEING DRAWN EACH TUESDAY AT THE VIKING LODGE, 6730 175TH STREET.
- G. CONSIDER PAYMENT OF OUTSTANDING BILLS IN THE AMOUNT OF \$1,457,065.27 AS LISTED ON THE VENDOR BOARD APPROVAL REPORTS DATED FRIDAY, MARCH 18 AND 25, AND APRIL 1, 2022.

ACTION: Discussion: **Consider approval of consent agenda items.**

COMMENTS: _____

ITEM #13

SUBJECT: CONSIDER ADOPTING ORDINANCE 2022-O-023 APPROVING A PURCHASE AND SALE AGREEMENT BETWEEN THE VILLAGE OF TINLEY PARK AND GSP DEVELOPMENT, LLC, FOR THE SALE OF PROPERTY LOCATED AT 7551 191ST STREET IN TINLEY PARK, ILLINOIS - **Trustee Mueller**

ACTION: Discussion: This Ordinance seeks approval of the execution of a purchase and sale agreement for the property located at 7551 191st Street (southwest corner of 191st and Harlem Avenue) to GSP Development, LLC in the amount of \$1,700,000. **This Ordinance is eligible for adoption.**

COMMENTS: _____

ITEM #14

SUBJECT: CONSIDER ADOPTING RESOLUTION 2022-R-029 APPROVING A QUALIFIED BASED SELECTION (QBS) PROCEDURE - **Trustee Mahoney**

ACTION: Discussion: Qualification Based Selection (QBS) ensures that federal agencies receive highly technical architect and engineering services from the most experienced and well qualified firms at a fair and reasonable cost. The QBS process is required by State and Federal law for certain public projects in Illinois. Adopting a standard Village QBS procedure provides consistency and expedites projects moving forward. This item was discussed at the Committee of the Whole Committee held prior to this meeting. **This Resolution is eligible for adoption.**

COMMENTS: _____

ITEM #15

SUBJECT: CONSIDER ADOPTING RESOLUTION 2022-R-030 APPROVING A FIRST AMENDMENT TO THE INTERGOVERNMENTAL AGREEMENT (IGA) BETWEEN THE VILLAGE OF TINLEY PARK AND COOK COUNTY, ILLINOIS BY AND THROUGH THE DEPARTMENT OF TRANSPORTATION AND HIGHWAYS FOR 175TH STREET - OAK PARK AVENUE TO RIDGELAND AVENUE - **Trustee Mahoney**

ACTION: Discussion: This Resolution seeks approval of an amendment to Resolution 2017-R-040, an IGA with Cook County increasing the County's total estimated cost for the 175th Street - Oak Park Avenue to Ridgeland Avenue project from \$482,562 to \$532,560. This item was discussed at the Committee of the Whole meeting held prior to this meeting. **This resolution is eligible for adoption.**

COMMENTS: _____

ITEM #16

SUBJECT: CONSIDER ADOPTING RESOLUTION 2022-R-031 APPROVING A SERVICE CONTRACT BETWEEN THE VILLAGE OF TINLEY PARK AND CARDNO, NOW STANTEC, FOR STORMWATER AREA MAINTENANCE - FY 2023 (YEAR 1 OF 3) - **Trustee Mahoney**

ACTION: Discussion: This requested service contract is for a qualified contractor to provide maintenance for stormwater areas including installation and stewardship for naturalized areas at various locations throughout the Village. Public Works is recommending that we approve a service contract to Cardno, now Stantec, in the amount of \$228,000. This item was discussed at the Committee of the Whole meeting held prior to this meeting. **This Resolution is eligible for adoption.**

COMMENTS: _____

ITEM #17

SUBJECT: CONSIDER ADOPTING RESOLUTION 2022-R-032 APPROVING A SERVICE CONTRACT BETWEEN THE VILLAGE OF TINLEY PARK AND CITY ESCAPE GARDEN AND DESIGN, LLC FOR LANDSCAPE BED MAINTENANCE (YEAR 1 OF 3) - **Trustee Mahoney**

ACTION: Discussion: This requested service contract is for a qualified contractor to provide maintenance to the Villages' 5.6 acres of landscape beds throughout Tinley Park. Public Works is recommending that we approve a contract to City Escape Garden and Design, LLC in the amount of \$153,089.46. This item was discussed at the Committee of the Whole meeting held prior to this meeting. **This Resolution is eligible for adoption.**

COMMENTS: _____

ITEM #18

SUBJECT: RECEIVE COMMENTS FROM STAFF -

COMMENTS: _____

ITEM #19

SUBJECT: RECEIVE COMMENTS FROM THE BOARD -

COMMENTS: _____

ITEM #20

SUBJECT: RECEIVE COMMENTS FROM THE PUBLIC -

COMMENTS: _____

ADJOURNMENT

**MINUTES OF THE SPECIAL BOARD MEETING OF THE TRUSTEES,
VILLAGE OF TINLEY PARK, COOK AND WILL COUNTIES,
ILLINOIS, HELD MARCH 15, 2022**

The special meeting of the Board of Trustees, Village of Tinley Park, Illinois, was held in the Council Chambers located in the Village Hall of Tinley Park, 16250 Oak Park Avenue, Tinley Park, IL on March 15, 2022. President Glotz called this meeting to order at 5:16 p.m.

At this time President Glotz led the Board and audience in the Pledge of Allegiance.

At this time President Glotz and Trustee Brady called for a moment of silence for the people of the Ukraine.

Clerk O'Connor called the roll. Present and responding to roll call were the following:

Village President:	Michael W. Glotz
Village Clerk:	Nancy O'Connor
Trustees:	William P. Brady William A. Brennan Dennis P. Mahoney Michael G. Mueller Colleen M. Sullivan
Absent:	Diane M. Galante
Also Present:	
Village Manager:	Patrick Carr
Asst. Village Manager:	Hannah Lipman
Village Attorney:	Paul O'Grady

Motion was made by Trustee Brennan, seconded by Trustee Mahoney to approve the agenda as written or amended for this meeting. President Glotz asked if there were any comments from members of the Board or public. There were none. Vote on roll call. Ayes: Brady, Brennan, Mahoney, Mueller, Sullivan. Nays: None. Absent: Galante. President Glotz declared the motion carried.

Motion was made by Trustee Brennan, seconded by Trustee Mueller to approve and place on file the minutes of the Regular Village Board Meeting held on March 1, 2022. President Glotz asked if there were any comments from members of the Board or public. There were none. Vote on roll call. Ayes: Brady, Brennan, Mahoney, Mueller, Sullivan. Nays: None. Absent: Galante. President Glotz declared the motion carried.

At this time President Glotz presented the Tinley Park Business Spotlight.

- St. Coletta's of Illinois, 18350 Crossing Drive

At this time a presentation of Official Recognition of the Village's Class 6 Flood Insurance Rating to Public Works Director John Urbanski was made.

Motion was made by Trustee Mueller, seconded by Trustee Sullivan to consider approving the following Consent Agenda items:

- A. CONSIDER ADOPTING RESOLUTION 2022-R-023 APPROVING A CONTRACT RENEWAL BETWEEN THE VILLAGE OF TINLEY PARK AND TRUGREEN IN THE AMOUNT OF \$41,107 FOR 2022 LAWN TREATMENTS.
- B. CONSIDER PAYMENT OF OUTSTANDING BILLS IN THE AMOUNT OF \$4,095,175.17 AS LISTED ON THE VENDOR BOARD APPROVAL REPORTS DATED MARCH 4 AND 11, 2022.

President Glotz asked if anyone from the Board would like to remove or discuss any items from the Consent Agenda. No items were removed or discussed. President Glotz asked if there were any comments from members of the public. There were none. Vote on roll call. Ayes: Brady, Brennan, Mahoney, Mueller, Sullivan. Nays: None. Absent: Galante. President Glotz declared the motion carried.

Motion was made by Trustee Mueller, seconded by Trustee Brennan to adopt and place on file **ORDINANCE 2022-O-022 FOR A SPECIAL USE PERMIT TO PERMIT A RESTAURANT PICKUP WINDOW SPEAKER POST FOR DURBIN'S EXPRESS AT 18250 OAK PARK AVENUE.** The Petitioner, Thomas McAuliffe of Durbin's Pizza, has requested a change to the previously approved Restaurant Pickup Window Special Use to allow for a speaker post in the NF (Neighborhood Flex) Zoning District.

The Plan Commission held a Public Hearing on March 3, 2022, and voted 6-0 to recommend approval of the Special Use with conditions in accordance with the plans listed and Findings of Fact in the Staff Report. President Glotz asked if there were any comments from members of the Board or public. There were none. Vote on roll call. Ayes: Brady, Brennan, Mahoney, Mueller, Sullivan. Nays: None. Absent: Galante. President Glotz declared the motion carried.

Motion was made by Trustee Brady, seconded by Trustee Brennan, to adopt and place on file **ORDINANCE 2022-O-021 AUTHORIZING THE DISPOSAL OF SURPLUS PERSONAL PROPERTY OWNED BY THE VILLAGE OF TINLEY PARK – FLEET VEHICLE/EQUIPMENT.** The Public Works Fleet Vehicle/Equipment List for Disposal includes various items valued at over \$1,000. The Village uses multiple methods to achieve the highest amount of compensation for its surplus vehicles or equipment. Most items will be sold through Public Auctions or salvage and recycling companies. Consider authorizing the Public Works fleet vehicle/equipment list for disposal. President Glotz asked if there were any comments from members of the Board or public. Trustee Brady asked where the funds received from the auction sale of vehicles go. Financial and Administrative Consultant Brad Bettenhausen stated it goes back to the capital fund for purchase of equipment. Vote on roll call. Ayes: Brady, Brennan, Mahoney, Mueller, Sullivan. Nays: None. Absent: Galante. President Glotz declared the motion carried.

Motion was made by Trustee Brennan, seconded by Trustee Sullivan to adopt and place on file **RESOLUTION 2022-R-024 APPROVING A CONTRACT BETWEEN THE VILLAGE OF TINLEY PARK AND CITY ESCAPE GARDEN AND DESIGN, LLC FOR 2022 LANDSCAPE MAINTENANCE MOWING IN THE AMOUNT OF \$252,189.02.** Public Works is recommending that the Village award a contract for mowing service for our 234 acres of turf in various locations in Tinley Park. The contract has the option of two (2) – one (1) year renewals. This would be the first year out of the possible three (3) year contract.

The awarding of this contract to City Escape Garden and Design, LLC is in the amount of \$252,189.02. This item was discussed at the Committee of the Whole meeting held prior to this meeting. President Glotz asked if there were any comments from members of the Board or public. There were none. Vote on roll call. Ayes:

Brady, Brennan, Mahoney, Mueller, Sullivan. Nays: None. Absent: Galante. President Glotz declared the motion carried.

At this time a **PRESENTATION OF THE DRAFT 2023 FISCAL YEAR BUDGET** was made.

Assistant Village Manager Hannah Lipman and Financial Consultant Brad Bettenhausen presented an overview of the Fiscal Year (FY) 2023 Budget which included FY 2022 estimated actuals, FY 23 Estimated Revenues, Departmental Overviews, and Capital and Personnel Requests.

- FY 2022 Est. Actuals

	Revenue	Expenditure
General Fund	\$69,685,683	\$59,136,413
Hotel/Motel Tax Fund	\$ 2,056,000	\$ 1,132,135
Water & Sewer Fund	\$26,815,595	\$24,879,347
Storm Water Fund	\$ 729,725	\$ 696,230
Commuter Parking Lot (CPL)	\$ 201,140	\$ 418,850

- FY 2023 Proposed Key Revenues

General Fund	\$ 69,942,659
Property Tax	\$ 19,920,000
Sales Tax	\$26,600,000 *
Income Tax	\$ 7,406,000
Use Tax	\$ 1,830,000

*Does not include the impact of Governor's proposed tax holiday

Overview of Key Revenues was presented:

- Sales Taxes:
 - FY 2022 estimated revenues expected to exceed budget by 32%;
 - The economy has remained strong;
 - Benefits from “Leveling the Playing Field for Illinois Retail Act”;
 - Sales tax reporting for out of state and internet-based retail;
 - Monthly sales tax receipts have averaged 30% greater than the prior year; and
 - Expected stabilization January 2022 sales tax (received April 2022)
 - FY 2023 projected at a modest 2.2% overall increase; and
 - Anticipates partial year increased sales tax from a new grocer
- Use Taxes:
 - FY 2022 estimated revenues expected at 2% over budget;
 - “Leveling the Playing Field for Illinois Retail Act” shifts many out of state and internet retailers to collect sales tax versus Use Tax; and
 - Monthly tax receipts average a 13% decrease from the prior year (Net of impact to MT & HMR overall positive benefit)
 - FY 2023 projects continued decline in Use Tax distributions

- Income Taxes:
 - FY 2022 estimated revenues expected to be 32% over budget ;
 - Economy & employment has remained strong;
 - FY 2023 projects a modest 3% decrease;
 - Both Village and State populations decreased in the 2020 census will increase State per capita distributions by 0.5%; and
 - Offset by Village population decrease
- Amusement Taxes:
 - FY 2022 did not budget revenues to due COVID uncertainty;
 - Nearly \$667,000 in revenues estimated for the year; and
 - Music theater season started late consisting of only 17 shows which are below the historical average;
 - FY 2023 projects \$1,200,000 in revenues; and
 - Potentially will be the largest season in the facility's 33-year history
- Telecom Tax & Franchise Fees:
 - FY 2022 estimated revenues expected to fall short of budget by 9%; and
 - Decrease in hardline phone services and cable services
 - FY 2023 projects continued declines

Overview of Departmental and Personnel Request Overview was presented.

- Overall, departments were directed to 'hold the line' and keep things status quo within their line items;
- However, in nearly all departments, training, meetings & conferences budgets were increased after having been cut due to COVID in the prior budget;
- Department compensation and benefit line items typically reflect increases after Human Resources worked with departments to ensure staffing hours were appropriately budgeted and the correct level of benefits included; and
- Certain line items were taken out of departmental budgets and centralized in Overhead (01-14) to facilitate monitoring the costs.
 - i.e. Recruiting Costs and Post-Employment Benefits

Overview of Capital Requests

There was \$8.2 million in capital project requested. The Treasurer and Manager recommend 7.6 million in capital projects. There is approximately \$20 million in Bond, American Rescue Plan Act, and Rebuilding Illinois funds received by the Village. This has helped move the Village forward on the Capital Requests in the FY 2023 budget. There are carryovers in this proposed budget some due to supply chain issues.

Overview of next steps in the budget process.

- Continue to receive input from the Village Board;
- Public Hearing (tentatively scheduled for April 5, 2022); and
- Final adoption April 19, 2022, Village Board Meeting

The President and Board thanked the Finance Staff and Department Heads for their hard work on the budget. President Glotz asked if there were any comments from members of the Staff. There were none. President Glotz asked if there were any comments from members of the Board.

President Glotz thanks Village Staff, Volunteers, Residents, and Business Owners for making the St. Patrick's Day Parade a success. He noted the Knights of Columbus fundraiser was a success and he enjoyed the entertainment.

President Glotz thanked Police Chief Matt Walsh for attending the Archer Avenue Parade with him on Saturday, March 12th. The parade was in honor of fallen Police Officer Ella French.

Trustee Brady noted that the Village float in the St. Patrick's Day parade was decorated by Boy Scout Troop 911 and the Sea Scouts. These troops are sponsored by the Tinley Park Police. He thanked the troops and EMA for help with the float.

Trustee Brady noted that the Tinley Park Park District will be holding a free boating safety course on March 27th and 26th. Contact the Park District for more information.

President Glotz asked if there were any comments from members of the public. There were none.

Motion was made by Trustee Mueller, seconded by Trustee Mahoney, at 6:14 p.m. to adjourn to Executive Session to discuss the following:

- A. THE APPOINTMENT, EMPLOYMENT, COMPENSATION, DISCIPLINE, PERFORMANCE, OR DISMISSAL OF SPECIFIC EMPLOYEES OF THE PUBLIC BODY OR LEGAL COUNSEL FOR THE PUBLIC BODY, INCLUDING HEARING TESTIMONY ON A COMPLAINT LODGED AGAINST AN EMPLOYEE OF THE PUBLIC BODY OR AGAINST LEGAL COUNSEL FOR THE PUBLIC BODY TO DETERMINE ITS VALIDITY.
- B. THE PURCHASE OR LEASE OF REAL PROPERTY FOR THE USE OF THE PUBLIC BODY, INCLUDING MEETINGS HELD FOR THE PURPOSE OF DISCUSSING WHETHER A PARTICULAR PARCEL SHOULD BE ACQUIRED.

Vote on roll call. Ayes: Brady, Brennan, Mahoney, Mueller, Sullivan. Nays: None. Absent: Galante. President Glotz declared the motion carried.

Motion was made by Trustee Brennan, seconded by Trustee Brennan, to adjourn the Village Board meeting at 6:40 p.m. Vote on roll call. Ayes: Brady, Brennan, Mahoney, Mueller, Sullivan. Nays: None. Absent: Galante. President Glotz declared the motion carried.

PLEASE NOTE: Where there is no summary of discussion on any items in the minutes, this reflects that no discussion occurred other than the introduction of the item.

APPROVED:

Village President

ATTEST:

Village Clerk

TINLEY PARK



PROCLAMATION

Recognizing April 10-16, 2022 as National Public Safety Telecommunicators Week in the Village of Tinley Park

WHEREAS, emergencies can occur at any time that require police, fire or emergency medical services; and

WHEREAS, when an emergency occurs the prompt response of police officers, firefighters, and paramedics is critical to the protection of life and preservation of property; and

WHEREAS, the safety of our police officers and firefighters is dependent upon the quality and accuracy of information obtained from citizens who telephone the Village of Tinley Park emergency communications center; and

WHEREAS, Public Safety Telecommunicators are the first and most critical contact our citizens have with emergency services; and

WHEREAS, Public Safety Telecommunicators are the single vital link for our police officers and firefighters by monitoring their activities by radio, providing them information and ensuring their safety; and

WHEREAS, Public Safety Telecommunicators of the Village of Tinley Park have contributed substantially to the apprehension of criminals, suppression of fires and treatment of patients; and

WHEREAS, each dispatcher has exhibited compassion, understanding, and professionalism during the performance of their job in the past year; and

NOW, THEREFORE, BE IT RESOLVED, that the President and Board of Trustees of the Village of Tinley Park, Cook and Will Counties, Illinois, declares the week of April 10 through 16, 2022, to be National Public Safety Telecommunicators Week in the Village of Tinley Park, in honor of the men and women whose diligence and professionalism keep our city and citizens safe.

APPROVED this 5th Day of April 2022

MICHAEL W. GLOTZ, VILLAGE PRESIDENT



NANCY M. O'CONNOR, VILLAGE CLERK

TRUSTEE WILLIAM P. BRADY

TRUSTEE WILLIAM A. BRENNAN

TRUSTEE DIANE M. GALANTE

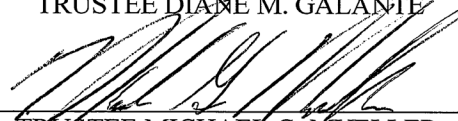
TRUSTEE DENNIS P. MAHONEY

TRUSTEE MICHAEL G. MUELLER

TRUSTEE COLLEEN M. SULLIVAN

TINLEY PARK BUSINESS SPOTLIGHT

President Glotz and
Clerk O'Connor

CONSIDER THE APPOINTMENT OF:

ORLANDO PIMENTEL - 911 DISPATCHER

SANDRA YOUNG - APPLICATION SUPPORT ANALYST

AMANDA GAUS - SPECIAL EVENTS SPECIALIST

President Glotz

**Interoffice**Issued/Approved by: **Stephen C. Klotz**, ^{SK}
Fire Chief Administrator

Memo

Memo #22-27

Date: February 22, 2022

To: Pat Carr, Village Manager

From: Stephen Klotz, Fire Chief Administrator

Subject: Fire Department Chaplain

Over the years fire service has experienced an increase of mental health issues, emotional stress, and suicides. Many of these issues stems from the types of incidents experienced by firefighters on the calls they respond to everyday. We do a great job of preparing our firefighters for combat with daily training, great personnel protective gear, and all the tools they need for the incidents they respond to. Currently, one of the most important tools we do not provide them is the mental health tool. The department Chaplain would be a person to talk to after a stressful incident, or loss of life.

I would like to put a Fire Department Chaplain on staff to help with some of the following:

- Level of uncertainty
- Interpersonal tension
- Extreme physical conditions
- Human tragedy
- Fear

The Chaplain will also work with Fire Department personnel on a regular basis to accomplish the following:

- Comfort and counsel
- Watch for signs of physical or emotional stress
- Visit the crews while on-duty
- Attend fire department functions
- Visit members who may be sick or in the hospital
- Help with the administrating of Critical Incident Stress Debriefing
- Respond to large scale critical incidents

My goal is to get one Chaplain on-board, then eventually expand the program to include other Chaplains in the area. I have had interest from a couple of pastors that would be honored in meeting this challenge. The Chaplain program would be managed through the Fire Department Administration, and a formal General Order for Fire Department Chaplain.

Thank you for your consideration in this matter.

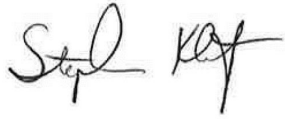

*Stephen C. Klotz,
Fire Chief Administrator*

SCK/mb

	<h1>Tinley Park Fire Department Manual</h1>	Fire Chaplain		G.O. 111
		100 - Administration		
		Effective: March 1,2022		
		REPLACES:		Low
		Authorized by	Stephen Klotz, Fire Chief	

SUMMARY: Qualifications, Requirements and Responsibilities of the Chaplain

OBJECTIVE: To provide for full range of fire department personnel needs through the establishment of a chaplaincy program within the Tinley Park Fire Department.

PROCEDURE: Because of the major risk and constant stresses faced by fire service personnel in the line of duty, a Chaplain will be appointed to function within the Tinley Park Fire Department. The Chaplain will be appointed by written order of the Fire Chief. The Chaplain is not held to confidentiality in matters concerning current child abuse, intended suicide/homicide or threat of bodily injury to self or danger to others.

Qualifications and Training:

1. Will be an Ordained member of the clergy
2. In good physical health
3. Interested in the Fire Service
4. Willing to commit the time to make the ministry effective
5. Committed to learn the skills necessary to effectively relate to and minister to the firefighters
6. Must be able to pass a criminal background check
7. Demonstrate compassion, understanding and strong ethical and moral beliefs

To the extent possible, the Chaplain will be given the opportunity to meet with members and staff of the department, visit the stations and receive guidance in understanding fire department organization and General Orders. Training will also be provided to help protect themselves and be able to render proper help at an emergency scene.

Emergency Situations:

The Chaplain will respond when dispatched by radio or a call from dispatch or command when available. When the Chaplain arrives at an Emergency Scene they will report to the Incident Commander. The Chaplain will respond when available but not limited to the following situations:

1. Working fire in progress
2. Critical incident in progress
3. Critical injury or death to a firefighter
4. Whenever the Incident Commander determines that the service of the Chaplain may be of value in the ongoing emergency operation.

Response to the Hospital:

1. If the Incident Commander or Fire Chief determines that the victim or family may need support.
2. If the victim’s family needs to be located and notified
3. If a member of the fire department is the victim

Follow-up Actions:

1. Comfort and counsel victims while on the scene
2. Watch for signs of physical or emotional stress of the firefighters
3. Assist with providing firefighters needs such as water, rest, ect.

	<h1>Tinley Park Fire Department Manual</h1>	Fire Chaplain		G.O. 111
		100 - Administration		
		Effective: March 1,2022		
		REPLACES:		Low
		Authorized by	Stephen Klotz, Fire Chief	

4. Report any Chaplain needs to the Incident Commander
5. Insure firefighter’s needs are met after the incident in the areas of on-the-job injuries, critical incident stress, etc.

Routine Duties:

1. Visit all the stations and shift whenever possible
2. Visit hospitalized department members
3. Participate in recruit training as suggested by the Chief of the Training Division
4. Be available for helping members in times of stress or difficulty.
5. Assist when requested by any division within the department
6. Attend fire department functions when possible
7. Conduct funeral/memorial services as needed and requested
8. Be a member of the Critical Incident Stress Debriefing team

General Guidelines for the Chaplaincy:

The Chaplain does not replace the home church pastor, but seeks to support the concern of every church for its members who may be in professions with special risks or needs. Moreover, the Chaplain must be for the advantage of every member of the department, regardless of his or her nationality, race, sex, or religion.

Any communication a person makes to the Chaplain is on a strictly confidential basis and will not be released to department members or any other person. Any fire personnel may go to the Chaplain without having to notify his or her supervisor or anyone else.

Any fire department officer or member (including administrative staff) who is made aware of any situation which may need the response of the Chaplain may contact the Chaplain directly. Fire department administration will keep current telephone numbers for the Chaplain. The Chaplain may also be contacted through fire department administration if desirable.

Issued Equipment:

After appointment the Chaplain will be issued the following equipment:

1. Basic PPE with a helmet with a Chaplain shield affixed to it
2. Chaplain badge, identification card
3. FD Call pager and the G2 app for the phone
4. Chaplain business cards

REFERENCES: Federation of Fire Chaplains

FORMS:

CONTACT: Deputy Chief

CONSIDER THE APPOINTMENT OF:

TIMOTHY O'HAGAN - ASSISTANT FIRE CHIEF

WILLIAM MURRAY - ASSISTANT FIRE CHIEF

President Glotz

**CONDUCT A SWEARING IN CEREMONY
FOR
ASSISTANT FIRE CHIEF TIMOTHY
O'HAGAN
AND
ASSISTANT FIRE CHIEF WILLIAM
MURRAY**

THE VILLAGE OF TINLEY PARK
Cook County, Illinois
Will County, Illinois

RESOLUTION
NO. 2022-R-025

**A RESOLUTION AUTHORIZING AN AGREEMENT WITH BETTENHAUSEN &
ASSOCIATES, LLC FOR AN AMOUNT NOT TO EXCEED \$90,000**

MICHAEL W. GLOTZ, PRESIDENT
NANCY M. O'CONNOR, VILLAGE CLERK

WILLIAM P. BRADY
WILLIAM A. BRENNAN
DIANE M. GALANTE
DENNIS P. MAHONEY
MICHAEL G. MUELLER
COLLEEN M. SULLIVAN
Board of Trustees

RESOLUTION NO. 2022-R-025**A RESOLUTION AUTHORIZING AN AGREEMENT WITH BETTENHAUSEN & ASSOCIATES, LLC FOR AN AMOUNT NOT TO EXCEED \$90,000**

WHEREAS, the Village of Tinley Park, Cook and Will Counties, Illinois, is a Home Rule Unit pursuant to the Illinois Constitution of 1970; and

WHEREAS, the Corporate Authorities of the Village of Tinley Park, Cook and Will Counties, Illinois, have considered approving a staffing agreement with Bettenhausen & Associates, LLC, a true and correct copy of such agreement being attached hereto and made a part hereof as **EXHIBIT 1**; and

WHEREAS, the Corporate Authorities of the Village of Tinley Park, Cook and Will Counties, Illinois, have determined that it is in the best interests of said Village of Tinley Park that said Agreement be entered into by the Village of Tinley Park;

NOW, THEREFORE, Be It Resolved by the President and Board of Trustees of the Village of Tinley Park, Cook and Will Counties, Illinois, as follows:

Section 1: The Preambles hereto are hereby made a part of, and operative provisions of, this Resolution as fully as if completely repeated at length herein.

Section 2: That this President and Board of Trustees of the Village of Tinley Park hereby find that it is in the best interests of the Village of Tinley Park and its residents that the aforesaid "Agreement" be entered into and executed by said Village of Tinley Park, with said Contract Extension to be substantially in the form attached hereto and made a part hereof as **EXHIBIT 1**, subject to review and revision as to form by the Village Attorney.

Section 3: That the President and Clerk of the Village of Tinley Park, Cook and Will Counties, Illinois are hereby authorized to execute for and on behalf of said Village of Tinley Park the aforesaid Contract.

Section 4: That this Resolution shall take effect from and after its adoption and approval.

ADOPTED this 5th day of April, 2022, by the Corporate Authorities of the Village of Tinley Park on a roll call vote as follows:

AYES:

NAYS:

ABSENT:

APPROVED this 5th day of April, 2022 by the President of the Village of Tinley Park.

Village President

ATTEST:

Village Clerk

EXHIBIT 1

**AUTHORIZING AN AGREEMENT WITH BETTENHAUSEN & ASSOCIATES, LLC
FOR AN AMOUNT NOT TO EXCEED \$90,000**

STATE OF ILLINOIS)
COUNTY OF COOK) SS
COUNTY OF WILL)

CERTIFICATE

I, NANCY M. O’CONNOR, Village Clerk of the Village of Tinley Park, Counties of Cook and Will and State of Illinois, DO HEREBY CERTIFY that the foregoing is a true and correct copy of Resolution No. 2022-R-025, “A RESOLUTION AUTHORIZING AN AGREEMENT WITH BETTENHAUSEN & ASSOCIATES, LLC FOR AN AMOUNT NOT TO EXCEED \$90,000,” which was adopted by the President and Board of Trustees of the Village of Tinley Park on April 5, 2022.

IN WITNESS WHEREOF, I have hereunto set my hand and affixed the corporate seal of the Village of Tinley Park this 5th day of April, 2022.

VILLAGE CLERK

INDEPENDENT CONTRACTOR AGREEMENT
TO PROVIDE PROFESSIONAL SERVICES AS INTERIM TREASURER/FINANCE
DIRECTOR AND DEPARTMENT SERVICES FOR THE VILLAGE OF TINLEY PARK

This Professional Services Independent Contractor Agreement ("Agreement") is made this 4th day of April, 2022, by and between the Village of Tinley Park, Illinois, ("VILLAGE") and Bettenhausen & Associates LLC ("BA LLC"). The VILLAGE and BA LLC may be referred to herein individually as "Party" or collectively as the "Parties."

1. **DEFINITION OF BA LLC.** As used in this Agreement, BA LLC shall be construed to include all of BA LLC' s officers, directors, members, managers, employees and agents.
2. **SERVICES.** BA LLC agrees to provide professional services as described in **EXHIBIT A** to this Agreement. The performance of the services by BA LLC under this Agreement shall not be construed as creating any employment relationship or employment contract or partnership or joint venture relationship between the VILLAGE and BA LLC. Professional Services will include:
 - A. Provide administrative assistance to the Finance Department and support the execution of the Department's Operating Plan.
 - B. Provide assistance with the Village's recently initiated bond issue.
 - i. Monitoring spend-out of proceeds to meet the "safe-harbor" rules to avoid the necessity of arbitrage calculations.
 - C. Assist Finance staff in preparing for the FY2022 audit report and related filings.
 - D. Supervise completion of Annual TIF reporting for FY 2021 and provide other related TIF analysis and assistance.
 - E. Aid in the finalization/assembly of the FY 2023 budget. Assist with budget implementation.
 - F. Assist in the evaluation and selection process for new ERP (enterprise resource program) financial, and related software applications.
 - G. Revenue and incentive tracking.

- H. Monitor tax exempt status of Village property acquisitions since 2018. Continue to work with Cook County regarding properties to be acquired through the No Cash Bid (NCB) program and related tax exemption applications.
 - I. Review and update written procedures and guidance regarding Finance and related activities. Where feasible, provide training to Finance and Administrative staff relative to such activities.
 - J. Assist in the transition of leadership within the Finance Department once new leadership is hired.
 - K. BA LLC agrees to provide any additional work as directed by the Village Manager and authorized separately by the Board of Trustees, and subject to separate authorization.
3. **TERM.** The Term of the agreement shall commence on 4 April, 2022. The professional services work will coincide with the needs of the VILLAGE to address issues in the Finance Department. In accordance with **Exhibit A** to this Agreement, the Village Manager shall provide a three week notice of project completion to permit project assignment closeout and any final report preparation.
- 1 4. **COMPENSATION.** The compensation will be for the completion of the Professional Services elements as described in **Exhibit A** to this agreement. Additional work elements as may be requested by the Village will be priced subject to the approval of the parties.
BA LLC shall provide a no less than monthly invoice to the Village Manager or his designee. The VILLAGE shall make payment to BA LLC within thirty (30) days thereafter, subject to the approval of the rules governing the VILLAGE. In compliance with Village requirements, BA LLC will provide a W-9 prior to the first payment. No deductions of any kind whatsoever shall be made by the VILLAGE to any compensation paid to BA LLC for any and all applicable federal, state, local and other taxes and deductions, which shall remain the sole and exclusive obligation of BA LLC.
5. **INDEPENDENT CONTRACTOR STATUS.** BA LLC is retained by the VILLAGE only for the purposes and to the extent set forth in this Agreement, and BA LLC' s relation to the VILLAGE shall, during the term of this Agreement and period of its services hereunder, be that of an independent contractor. BA LLC shall be free to dispose of such portion of its entire time, energy and skill during regular business hours when BA LLC is not obligated to devote time and

services hereunder to the VILLAGE, in such manner as BA LLC sees fit and to such persons, firms or corporations as BA LLC deems advisable. It is acknowledged that at all times BA LLC is separate and independent from the VILLAGE and that BA LLC will utilize a high level of skill necessary to perform the services under this Agreement.

- A. Not an Employee. BA LLC shall not be considered as having an employee status, nor shall the VILLAGE withhold any sums for the payment of income taxes or FICA taxes, nor shall BA LLC be entitled to participate in any plans, arrangements or distributions by the VILLAGE pertaining to or in connection with any pension or retirement plans, or any other benefits for the regular full-time or part-time employees of the VILLAGE. As an independent contractor, it is the responsibility of BA LLC to file all necessary tax returns (federal, state, county and local) and to pay all income tax, social security, and any and all other taxes due as an independent contractor in its profession. As an independent contractor, BA LLC agrees that it is ineligible to file a claim for unemployment compensation benefits or for workers compensation benefits against the VILLAGE and agrees not to file such claims in the event this Agreement is terminated. BA LLC agrees to assume all risk of death, illness and injury relative to performing all services under this Agreement. BA LLC understands and agrees that, as an independent contractor, it is not an employee of the VILLAGE for any purposes of any kind and all state, federal and county laws or regulations that apply to or provide benefits or protections to employees do not apply to it, including, but not limited to, the application of the Fair Labor Standards Act minimum wage and overtime payments, Federal Insurance Contribution Act, the Social Security Act, the Federal Unemployment Tax Act and the Worker's Compensation Act (820 ILCS 305/1, et seq.).
 - B. No Insurance Provided by System. The VILLAGE will not provide any form of insurance coverage, including but not limited to health, worker's compensation, professional liability insurance or other employee benefits for or on behalf of BA LLC.
6. **INDEMNIFICATION.** BA LLC agrees to defend, indemnify and hold harmless the VILLAGE, its representatives, officers, trustees, agents, and employees from and against any and all claims, actions, suits, damages, costs, expenses and liabilities, including the reasonable fees and expenses of their attorneys, expert witnesses and consultants, court costs and fines, asserted against them or sought to be imposed upon them, individually, jointly or severally, and which arise directly or indirectly out of or in connection in any way with BA LLC' s performance of the terms of this Agreement, except to the extent that those

claims, actions, suits, damages, costs, expenses and liabilities arise from the sole negligence of the VILLAGE, its representatives, officers, trustees, agents and employees.

The scope of BA LLC's indemnification shall include, but is not limited to:

- A. Any negligent, tortuous or wrongful act or omission of the BA LLC, its officers, agents, employees, contractors or subcontractors, resulting in personal injury, bodily injury, sickness or death to any person, loss or damage of any kind to the property of any person, including BA LLC, its officers, agents, employees, and licensees, or damage to or loss of other intangible property rights or personal rights, including but not limited to libel, slander and invasion of privacy; and
 - B. Loss or damage of any kind resulting from the BA LLC's failure to comply with any provision of this Agreement, or of any federal, state or local law or regulation applicable to the BA LLC.
7. **INSURANCE**. As part of the indemnification required by this Agreement, but without limiting the same, BA LLC agrees to carry, during the term of this Agreement, at its expense, public liability insurance, including, but not limited to coverage for bodily injury, death, and property damage written on the comprehensive form, in the amount of \$1,000,000 per occurrence and \$2,000,000 aggregate.
 8. **EQUIPMENT**. The VILLAGE will provide an office space and any equipment (e.g., computers), and clerical support to BA LLC to the extent that it is presently available.
 9. **CONFIDENTIALITY**. BA LLC agrees to maintain the confidentiality of all VILLAGE information and documents received or obtained or learned as part of attending VILLAGE meetings and/or executive sessions or in performing its duties under this Agreement, unless specifically directed to release such information or documents by the VILLAGE or a court order or government regulatory agency order. BA LLC agrees that all conversations by attendees of and any information or documents reviewed or discussed in any executive session are confidential and shall not be disclosed or released by BA LLC, unless specifically directed to release such information or documents by the VILLAGE, a court order or government regulatory agency order. BA LLC shall faithfully adhere to the requirements of this Agreement and the professional ethical principles applicable hereto, including, but limited to, the ICMA Code of Ethics, and shall avoid all personal acts that might injure the reputation of the VILLAGE or undermine the business transactions and other operations of the VILLAGE.

10. **TERMINATION.**
- A. The Village may terminate this Agreement without cause upon thirty (30) days written notice to BA LLC. In the event of termination pursuant to this paragraph (10. A.), the Village shall pay BA LLC any Fees then due and payable for any Services completed up to and including the date of such termination.
 - B. The Village may terminate this Agreement in the event that BA LLC breaches this Agreement.
 - i. The Village shall provide written notice to BA LLC promptly after a breach has been identified.
 - ii. BA LLC shall cure such breach within ten (10) days after receipt of said written notice.
 - iii. If the breach is not cured, or such breach is incapable of cure, the termination of the agreement will become effective immediately thereafter.
11. **WAIVER AND ASSUMPTION OF LIABILITY.** BA LLC assumes all risks and liability for personal injuries or illness of any kind or death that might occur while performing any services or acting under this Agreement. BA LLC assumes all risks, liability and responsibility for its personal property while performing any services under this Agreement. BA LLC agrees to waive any claims or causes of action of any kind against the VILLAGE, except for non-payment for actual services rendered under this Agreement.
12. **APPLICABLE LAW.** The statutes and common law of the State of Illinois shall govern the interpretation, validity, enforcement and performance of the terms of this Agreement. The Parties agree that, for the purpose of any litigation or proceeding brought with respect to this Agreement and its enforcement, venue shall be in the Circuit Court of Cook or Will County, Illinois, as determined by the VILLAGE and the Parties agree to voluntarily submit to the jurisdiction of such court for the purpose of any such litigation or proceeding.
13. **ASSIGNMENT.** This Agreement may not be assigned, transferred or conveyed by BA LLC without the prior written consent of the VILLAGE.
14. **NOTICES.** All written notices of any kind to be given or delivered under this Agreement shall be deemed to have been properly given if (a) delivered by hand, (b) delivered by a nationally recognized overnight courier service, or (c) sent by registered or certified United States Mail, return receipt requested and first class postage prepaid. Such notices shall be sent to the Parties at their respective addresses as follows:

If to the VILLAGE:

Mr. Patrick Carr, Village Manager
Village of Tinley Park
16250 Oak Park Ave
Tinley Park, Illinois 60477

With a copy to:

Village President Michael Glotz
Village of Tinley Park
16250 Oak Park Ave
Tinley Park, Illinois 60477

If to Bettenhausen Associates LLC:

Brad Bettenhausen
Bettenhausen & Associates LLC
16620 Fulton Ter
Tinley Park, IL 60477-1908

15. **AUTHORITY**. This Agreement shall be in full force and effect, and legally binding, after it is signed by the duly authorized officer of each party. Each of the signatories to this Agreement are the duly authorized representatives of their respective entity and each such person has signed this Agreement pursuant to the authority duly granted to him or her by the authorities of said entity, who have acted by motion or approved a resolution (in the VILLAGE's case, at an open public meeting) that authorized and directed the representatives to sign this Agreement. This Agreement shall be binding upon and shall inure to the benefit of the parties agreeing hereto and to their successor corporations, officers, officials, trustees, successors in office, heirs, representatives, and assigns.
16. **EFFECTIVE DATE**. This Agreement shall become effective on the date of the last signatory to sign and authorize this Agreement.

VILLAGE OF TINLEY PARK, ILLINOIS

Michael W. Glotz
Village President

Date _____

Bettenhausen & Associates LLC

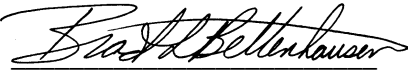

Brad Bettenhausen

Managing Director

Date 4 Apr 2022

EXHIBIT A

The Managing Director of BA LLC, is a Certified Public Accountant with over forty years of experience in public and governmental accounting, including previously serving as the Village's Treasurer/Finance Director for over 37 years spanning across five decades. There are few individuals that can bring both the governmental accounting and financial background and institutional knowledge of Tinley Park (as well as its history) to the table to address the current crisis created by the unexpected and untimely departure of the Treasurer/Finance Director with a minimum of familiarization lead time required. In other words, BA LLC can hit the ground running.

BA LLC has identified key work elements with importance to the Village of Tinley Park. The work plan itself will proceed with concurrent work plan tasks, as all of the issues BA LLC has identified are very important to Tinley Park. There are some functions, that are foreseen as being potentially beneficial to be handled on an ongoing basis over a longer horizon to assist the overall finance and administration activities and staff transitions. Upon approval of the agreement, BA LLC and the Village Manager will identify the specific tasks and priorities. The identified tasks include:

1. Provide administrative assistance to the Finance Department and support the execution of the Department's Operating Plan.
2. Provide assistance with the Village's recently initiated bond issue.
BA LLC would suggest that Assistant Village Manager Hannah Lipman, and at least one of the senior finance staff member, assist in this process so that BA LLC' Principal Consultant may provide training for the future and hopefully transfer some institutional knowledge in the process.
 - A. Monitoring spend-out of proceeds to meet the "safe-harbor" rules to avoid the necessity of arbitrage calculations.
3. Assist Finance staff in finalizing FY2021 audit report and related filings. Furthermore, assist staff in preparing for the FY2022 audit.
 - A. State Comptroller
 - B. County Clerks
 - C. Cook County Treasurer Debt Disclosure Ordinance (DDO)

- D. Participation in the GFOA Certificate of Achievement program
4. Supervise completion of Annual TIF reporting for FY 2021 and provide other related TIF analysis and assistance.
 - A. Filings with State Comptroller
 - B. Distribution of copies to Joint Review Board overlapping taxing bodies
 - C. TIF activity monitoring including TIF EAV analysis, incremental property tax projections, Tax Base analysis.
 - I. For potential new projects
 - ii. For existing TIF incentive agreements
 - iii. For overall TIF status
 - D. Prepare charts and graphs to be utilized for annual Joint Review Board meetings and for presentation to the Village Board.
 5. Assist Finance and administrative staff in the process of assembling and preparing the FY 2023 budget.
 6. Assist in the evaluation and selection process for new ERP (enterprise resource program) financial, and related software applications.
 7. Revenue and incentive tracking.
 - A. Sales Tax
(This will require updated authorizations under the Reciprocal Information Exchange agreement with the Illinois Department of Revenue. BA LLC will assist in preparing the necessary documents.)
 - B. State Revenue Distributions
(Income/LGDF, MFT, Cannabis, Video Gaming, etc.)
 - C. Incentive tracking
It is important to remain on top of the various existing incentive agreements and payments in order to not default on the Village's obligations under these arrangements. With familiarity of the requirements and timetables under agreements approved prior to June 2021, BA LLC would also review any incentive payments paid subsequent to June 2021 to assure that they have been calculated properly.
 - D. Confirm that any newly approved/activated sales tax incentive disclosures have been filed with Illinois Department of Revenue as required by state statute.
 - E. Assist with implementation of the approved Storage Facilities Tax. Shortly after adoption, action had been deferred in 2020 due to COVID and it is unlikely it has moved forward to live status.
 - F. Assist in reviewing/implementing other revenue options (e.g. Food and Beverage Tax).

8. Assess status of Village grants and reporting requirements. Assist Finance staff as necessary.
9. Monitor Village real estate property records
 - I. Monitor status of tax exemption applications pending at end of June 2021, and any parcels that may have been subsequently acquired by the Village. The tax exempt status of two Village property acquisitions in 2018 had not been approved as of June 2021 and continued monitoring of status is required.
 - ii. Properties to be acquired through the Cook County No Cash Bid (NCB) program and related tax exemption applications.
 - A. Continue monitoring the status of properties that the Village is attempting to acquire through the NCB program that remained pending and in limbo due to COVID delays at end of June 2021.
 - B. Prepare any related reporting required to the County.
 - C. Review and monitor for additional potential parcels that the Village would benefit by acquisition through the NCB and related programs.
 - iii. Annual Tax Exemption filings with Cook and Will Counties for Village owned properties.
 - iv. Provide training to appropriate finance and administrative staff relative to this annual process/requirement.
10. Property tax levy

BA LLC is aware that the Village Board has already provided its required determination of estimate of levy reflecting a 1% increase over the prior year.

 - I. Review the levy ordinance and related tax abatement ordinances prior to adoption.
 - ii. Assist the Deputy Clerk with the preparation of appropriate Certificate of Compliance with regard to the Truth in Taxation Act to be submitted with the approved levy.
 - iii. Assist the Deputy Clerk with County filings of adopted ordinances.
 - iv. Provide additional training to appropriate finance and administrative staff relative to this process for the future.
11. Review and update written procedures and guidance regarding Finance and related activities. Where feasible, provide training to Finance and Administrative staff relative to such activities in an attempt to transfer institutional knowledge and promote greater "self-sufficiency" amongst the Finance and Management teams going forward.
12. Assist in the transition of leadership within the Finance Department once new leadership is hired.

13. Assist with the ERP (Enterprise Resource Program) financial software selection and implementation.
As the current ERP software is nearing its end of life (i.e. will soon be no longer supported by the software company), it is critical that this process not be delayed or stalled. It has long been a Village goal and objective that financial activities are directly integrated into the ERP as much as possible or have direct interfaces to the selected ERP. (By an analogy - stimulating the growth of one big tree, rather than a forest of small trees). Integration with the ERP is viewed as critically important for related applications such as HR software that is being considered.
14. BA LLC agrees to provide any additional work as directed by the Village Manager and authorized separately by the Board of Trustees, and subject to separate authorization.

Other Terms

Brad Bettenhausen will serve as Principal Consultant under this agreement.

The Tinley Park engagement is complex and some tasks are under a tight time line, but both are expected to be well within the capabilities of BA LLC and its representatives to execute and perform the required tasks.

While BA LLC will be heavily relying on Department personnel for support, some additional support may be necessary; Associate Consulting time could also be required to help in the project work elements. BA LLC envisions spending no more than three days a week on site, with possibly some exceptions as may be required from time to time due to the task or activity.

Billing rates:

Principal Consultant \$150 per hour

Associate Consultant \$125 per hour (if required)

Out of pocket costs, if any, will be billed in addition to the above amounts.

Transportation to and from the Village is not charged, and will not be included in the billing.

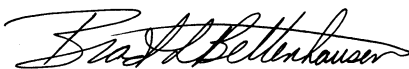

Brad Bettenhausen
Managing Director
Bettenhausen & Associates LLC

**Interoffice****Memo**

Date: February 10, 2021

To: **Committee of the Whole**

From: Donna Framke, Marketing Director

Subject: *Tinley Park Life Amplified* Tourism Website

The marketing department has been working diligently with Point B Communications to develop the creative design and messaging required to take the *Tinley Park Life Amplified* brand out to market. I will unveil that for you in the coming weeks. The next step in the process of building our tourism infrastructure is the design and development of a dedicated VisitTinleyPark.com website.

Currently, Tinley Park's visitor information is housed beneath the Visitor tab on the TinleyPark.org website. Although that site reflects the Tinley Park Life Amplified brand and the visitor content is accessible via a redirect of the VisitTinleyPark.com URL, the site exists as a content-heavy, governmental site, which is limited and makes the visitor and event planners' user experience difficult to navigate.

The proposed site will be focused on promoting Tinley Park as a destination, using an open source CMS optimized for organic search and mobile usage. We will build upon the content that exists on our visitor tab, which simply inventories our hospitality amenities, and develop engaging messaging and aesthetics that will be supported by multiple heading styles, fonts and photos designed to encourage users to read more, click through and stay on the site a little longer. The end result will be a digital touchpoint presented with a fresh, clean and updated look designed to inform potential visitors of the many entertainment options available. The site will also provide a full-service RFP submission portal for future convention and meeting event planners.

The creation and development of this website is expected to take 16 – 18 weeks and will be paid for from Hotel-Motel tax.





Interoffice

Memo

Date: March 28, 2022

To: Pat Carr – Village Manager
Hannah Lipman – Assistant Village Manager/Interim Village Treasurer
John Urbanski, Public Works Director

From: Terry Lusby, Jr. – Facilities/Fleet Superintendent

Subject: Intergovernmental Agreement for School District 140 School Safety Lights at 80th Ave./167th St.

Presented for Committee of the Whole/Village Board Meeting consideration and possible action:

Description:

Village staff met with Kirby School District 140 administration and investigated the need to install two solar powered school zone safety flashing beacon assemblies. Based on the collected data, staff recommends both entities split the costs to install the two (2) safety flashing beacon assemblies to increase driver awareness and enhance safety precautions for children, adults, and Village employees (crossing guards) utilizing the crosswalk at 80th Ave and 167th St. Kirby School District 140 will be fully responsible for the maintenance, operation, and any future costs for the safety flashing beacon assemblies after construction and installation. The plans and specifications were prepared by Christopher Burke Engineering.

The total estimated project cost will be \$40,000 with the Kirby School District 140 providing \$20,000 and the Village providing \$20,000.

Staff Direction Request:

1. Approve the Intergovernmental Agreement (IGA) between the Village and Kirby School District 140.
2. Direct Staff as necessary.

Attachments:

1. Intergovernmental Agreement with Kirby School District 140.
2. Safety flashing beacon assembly plans and specifications.

THE VILLAGE OF TINLEY PARK
Cook County, Illinois
Will County, Illinois

RESOLUTION
NO. 2022-R-026

**A RESOLUTION AUTHORIZING AN INTERGOVERNMENTAL AGREEMENT BETWEEN
THE VILLAGE OF TINLEY PARK AND SCHOOL DISTRICT 140 FOR THE INSTALLATION
OF SCHOOL ZONE SAFETY LIGHTS**

MICHAEL W. GLOTZ, PRESIDENT
NANCY M. O'CONNOR, VILLAGE CLERK

WILLIAM P. BRADY
WILLIAM A. BRENNAN
DIANE M. GALANTE
DENNIS P. MAHONEY
MICHAEL G. MUELLER
COLLEEN M. SULLIVAN
Board of Trustees

RESOLUTION NO. 2022-R-026**A RESOLUTION AUTHORIZING AN INTERGOVERNMENTAL AGREEMENT BETWEEN THE VILLAGE OF TINLEY PARK AND SCHOOL DISTRICT 140 FOR THE INSTALLATION OF SCHOOL ZONE SAFETY LIGHTS**

WHEREAS, the Village of Tinley Park is a Municipal Corporation situated in Will and Cook Counties, (hereinafter referred to as “VILLAGE”) under and by virtue of the Constitution and laws of the State of Illinois and has acted in the exercise of its statutory authority in the exercise of this agreement; and

WHEREAS, Kirby School District 140 is a body corporate and politic (hereinafter referred to as the “DISTRICT”); and

WHEREAS, Article VII, Section 10, of the Constitution of the State of Illinois of 1970 provides that units of local government may contract or otherwise associate among themselves to obtain or share services and to exercise, combine or transfer any power or function in any manner not prohibited by law or by ordinance; and

WHEREAS, the Illinois Intergovernmental Cooperation Act, (Illinois Compiled Statutes, Chapter 5, Section 220/1 *et seq.*), authorizes municipalities to exercise jointly with any public agency of the State, including other units of local government, any power, privilege, or authority which may be exercised by a unit of local government individually, and to enter into contracts for the performance of governmental services, activities, and undertakings; and

WHEREAS, the VILLAGE and DISTRICT, in order to facilitate the safe passage of students and faculty, are desirous of installing two solar powered school safety light flashers at 167th Street and 80th Avenue in the VILLAGE.

WHEREAS, the VILLAGE and the DISTRICT have elected to cooperate with each other and set forth the rights and responsibilities of each party regarding the cost of the two solar powered school safety light flashers.

NOW THEREFORE, in consideration of the mutual promises, obligations and undertakings set forth herein, the VILLAGE and the DISTRICT agree as follows:

1. The above Recitals are substantive and are incorporated herein by reference as if fully set forth in this paragraph 1.
2. The VILLAGE shall install, at the DISTRICT’S shared expense, two solar powered school safety light flashers pursuant VILLAGE and the DISTRICT specifications, and as further described in **Exhibit A**.
3. Upon completion of the project, the DISTRICT shall be solely responsible for the maintenance, damage/repair, and energy costs of the two solar powered school safety light flashers at 167th Street and 80th Avenue.
4. The VILLAGE shall, at its own expense, make or cause to be made all surveys, construction plans, specifications, and estimates, furnish resident engineering and the construction engineer

and provide or cause to be provided the material inspection of the project which is to be built in accordance with the approved plans and specifications.

- 5. Upon award of the contract for the improvement, the VILLAGE will invoice the DISTRICT for 50% of the amount of the estimated DISTRICT share of the construction costs not to exceed forty thousand dollars (\$40,000.00). Upon completion of the improvement and final acceptance by the DISTRICT, the VILLAGE and the DISTRICT will agree on each agency’s final share of the costs for the improvement based on the final actual costs.
- 6. This document shall be the final embodiment of the Agreement by and between the DISTRICT and VILLAGE. No oral changes or modifications for this Agreement shall be permitted or allowed. Changes or modification to this Agreement shall be made only in writing and upon the necessary and proper approvals of the DISTRICT and the VILLAGE.
- 7. All provisions of this Agreement shall be deemed severable, and if for any reason any portion of this Agreement is deemed invalid or unenforceable, or contrary to or in conflict with then applicable law then in any of such events, the invalid, unenforceable, conflicting or materially incompatible provisions shall be severed and deleted from this Agreement, without affecting the validity or enforceability of other provisions hereof.
- 8. This Agreement shall be binding upon and inure to the benefits of the parties hereto, their successors and assigns.
- 9. Venue for this agreement shall be in the courts of the Twelfth Judicial Circuit, Will County, Illinois and shall be governed by the laws of the State of Illinois irrespective of choice of law considerations.
- 10. Any notices under this Agreement shall be sent as follows:

If to the DISTRICT:

_____	_____
_____	_____
_____	_____
_____	_____

If to the VILLAGE:

Village of Tinley Park
 16250 S. Oak Park Avenue
 Tinley Park, IL 60477

Peterson, Johnson & Murray Chicago, LLC
 200 West Adams St., Suite 2125
 Chicago, IL 60606

The PARTIES agree that each shall be responsible to notify the other of any changes in notification procedures.

Dated at Joliet, Illinois this ____ day of _____, 20____.

ATTEST:

By _____
DISTRICT CLERK

By _____
DISTRICT Executive

(Seal)

Dated at Tinley Park, Illinois, this ____ day of _____, 20____.

ATTEST:

By _____
Village Clerk

Village President of Tinley Park

(Seal)

ADOPTED this this 5th day of April, 2022, by the Corporate Authorities of the Village of Tinley Park on a roll call vote as follows:

AYES:

NAYS:

ABSENT:

APPROVED this 5th day of April, 2022, by the President of the Village of Tinley Park.

Village President

ATTEST:

Village Clerk

EXHIBIT A

STATE OF ILLINOIS)
 COUNTY OF COOK) SS
 COUNTY OF WILL)

CERTIFICATE

I, NANCY M. O’CONNOR, Village Clerk of the Village of Tinley Park, Counties of Cook and Will and State of Illinois, DO HEREBY CERTIFY that the foregoing is a true and correct copy of Resolution No. 2022-R-026, **“A RESOLUTION AUTHORIZING AN INTERGOVERNMENTAL AGREEMENT BETWEEN THE VILLAGE OF TINLEY PARK AND SCHOOL DISTRICT 140 FOR THE INSTALLATION OF SCHOOL ZONE SAFETY LIGHTS,”** which was adopted by the President and Board of Trustees of the Village of Tinley Park on April 5, 2022.

IN WITNESS WHEREOF, I have hereunto set my hand and affixed the corporate seal of the Village of Tinley Park this 5th day of April, 2022.

VILLAGE CLERK

SCHOOL ZONE FLASHING BEACON SIGN ASSEMBLY INSTALLATION

80TH AVENUE AT 167TH STREET TINLEY PARK, ILLINOIS 60477

INDEX

- 1 TITLE SHEET
- 2 SUMMARY OF QUANTITIES
- 3 SIGN REMOVAL PLAN
- 4 - 5 SCHOOL ZONE FLASHING BEACON INSTALLATION AND SIGNING PLAN
- 6 - 21 TRAFFIC CONTROL HIGHWAY STANDARDS

LOCATION / VICINITY MAP

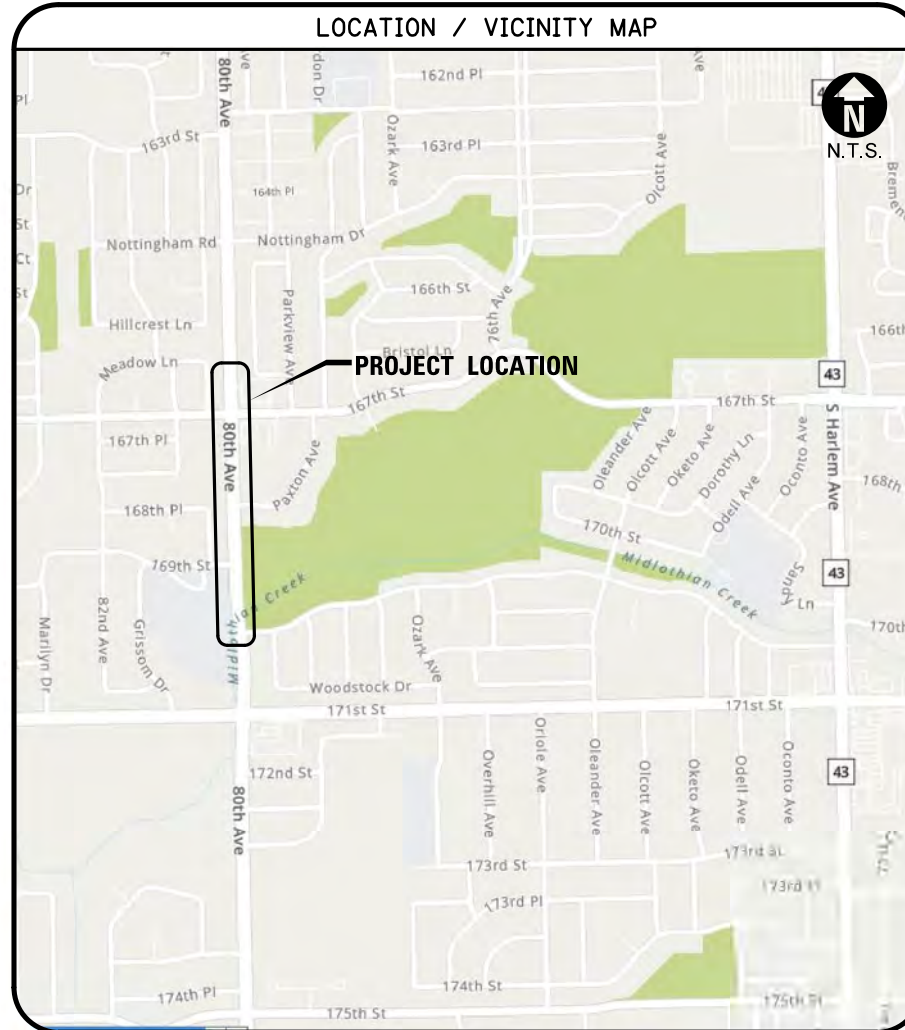

IDOT STANDARDS

STD. NO.	DESCRIPTION
000001-08	STANDARD SYMBOLS, ABBREVIATIONS AND PATTERNS
001006	DECIMAL OF AN INCH AND OF A FOOT
701101-05	OFF - ROAD OPERATIONS, MULTILANE, 15' TO 24" FROM EOP
701602-10	URBAN LANE CLOSURE, MULTILANE, 2W WITH BIDIRECTIONAL LEFT TURN LANE
701801-06	SIDEWALK, CORNER OR CROSSWALK CLOSURE
701901-08	TRAFFIC CONTROL DEVICES
720001-01	SIGN PANEL MOUNTING DETAILS
720006-04	SIGN PANEL ERECTION DETAILS
728001-01	TELESCOPING STEEL SIGN SUPPORT DETAIL
873001-02	TRAFFIC SIGNAL GROUNDING AND BONDING
878001-11	CONCRETE FOUNDATION DETAILS

BENCH MARK

LOCATION

CALL JULIE 1-800-892-0123
WITH THE FOLLOWING:
COUNTY COOK
CITY-TOWNSHIP TINLEY PARK
SEC. & 1/4 SEC. NO. _____
48 HOURS BEFORE YOU DIG.
EXCLUDING SAT., SUN., & HOLIDAYS

George M. Ziegler 3-14-2022
ENGINEER DATE

GEORGE M. ZIEGLER
ILLINOIS REGISTRATION No. 062-045853
EXPIRATION DATE: 11-30-2023

CLIENT : VILLAGE OF TINLEY PARK
16250 OAK PARK AVENUE
TINLEY PARK, IL 60477

CB **CHRISTOPHER B. BURKE ENGINEERING, LTD.**
9575 W. Higgins Road, Suite 600
Rosemont, Illinois 60018
(847) 823-0500
PROFESSIONAL DESIGN FIRM No.: 184-001742
EXPIRATION DATE: 04-30-2023

SUMMARY OF QUANTITIES

ITEM	UNIT	TOTAL	80th Avenue - 167th Street to 170th Place
SIGN PANEL - TYPE 1	SQ FT	47	47
SIGN PANEL - TYPE 2	SQ FT	24	24
REMOVE SIGN PANEL - TYPE 1	SQ FT	53	53
RELOCATE SIGN PANEL - TYPE 1	SQ FT	40	40
TELESCOPING STEEL SIGN SUPPORT	FOOT	107	107
TRAFFIC SIGNAL POST, GALVANIZED STEEL 14 FT.	EACH	2	2
CONCRETE FOUNDATION, TYPE A	FOOT	8	8
REMOVE EXISTING SIGN POST	EACH	10	10
TRAFFIC CONTROL AND PROTECTION, COMPLETE	EACH	1	1
FLASHING BEACON INSTALLATION, SOLAR POWERED	EACH	2	2

CHRISTOPHER B. BURKE ENGINEERING, LTD.
 9575 W. Higgins Road, Suite 600
 Rosemont, Illinois 60018
 (847) 823-0500

CLIENT: **VILLAGE OF TINLEY PARK**
16250 OAK PARK AVENUE
TINLEY PARK, IL 60477

NO.	DATE	NATURE OF REVISION	CHKD.	MODEL:	DSGN.	EJ	TITLE:
					DWN.	BC	SUMMARY OF QUANTITIES 80TH AVENUE AND 167TH STREET TINLEY PARK, ILLINOIS
					CHKD.	GMZ	
					SCALE:		
					PLOT DATE:	3/13/2022	
					CAD USER:	eJensen	
						Default	
FILE NAME		N:\TINLEYPARK\160373\160373.00028\Traffic\02_S00_160373-028.dgn					

PROJ. NO. 160373.00028
 DATE: 3/3/2022
 SHEET 2 OF 21
 DRAWING NO.

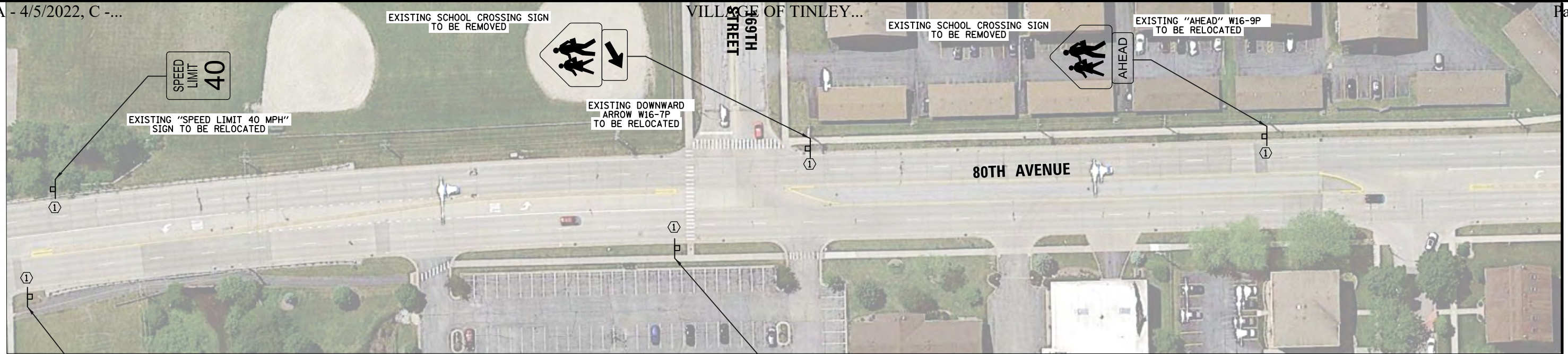

MATCH LINE A - A

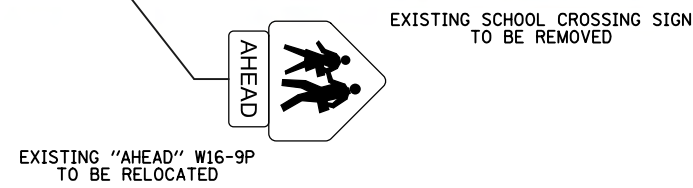

CONSTRUCTION NOTES:

- ① EXISTING SIGN POST TO BE REMOVED.
- EXISTING DOWNWARD ARROW W16-7P TO BE RELOCATED

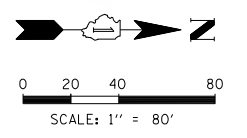
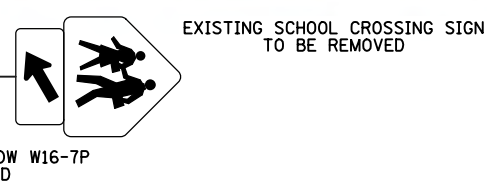

MATCH LINE A - A

CHRISTOPHER B. BURKE ENGINEERING, LTD.
 9575 W. Higgins Road, Suite 600
 Rosemont, Illinois 60018
 (847) 823-0500

CLIENT:
VILLAGE OF TINLEY PARK
16250 OAK PARK AVENUE
TINLEY PARK, IL 60477

NO.	DATE	NATURE OF REVISION	CHKD.	MODEL

TITLE:
SIGN REMOVAL PLAN
80TH AVENUE FROM 167TH STREET TO 169TH STREET
TINLEY PARK, ILLINOIS

PROJ. NO. 160373.00028
 DATE: 3/3/2022
 SHEET 3 OF 21
 DRAWING NO.

CONSTRUCTION NOTES:

- ① THE CONTRACTOR SHALL RELOCATE THE EXISTING SIGN PANEL AND/OR INSTALL A NEW SIGN PANEL ON THE PROPOSED TELESCOPING STEEL SIGN SUPPORT.
- ② THE FLASHING BEACON ASSEMBLIES SHALL BE PROGRAMMED TO OPERATE FROM 8:15 A.M. TO 8:45 A.M. AND FROM 3:15 P.M. TO 3:45 P.M., MONDAY THROUGH FRIDAY DURING THE SCHOOL YEAR AND HAVE A HOLIDAY SCHEDULE PROGRAMMED AS WELL. THE CONTRACTOR SHALL COORDINATE WITH THE VILLAGE FOR PROGRAMMING APPROVAL OF THE FLASHERS.
- ③ ALL SIGNS INSTALLED ON TELESCOPING STEEL SIGN SUPPORTS SHALL BE OFFSET 2' FROM FACE OF CURB TO EDGE OF SIGN IN ACCORDANCE WITH IDOT HIGHWAY STANDARD 720006. FLASHING BEACON CONCRETE FOUNDATIONS SHALL BE OFFSET 4' FROM BACK OF CURB TO CENTER OF FOUNDATION IN ACCORDANCE WITH IDOT D1 DETAIL TS-05.
- ④ EXISTING SIGNS AND EXISTING SIGN POST SHALL REMAIN.

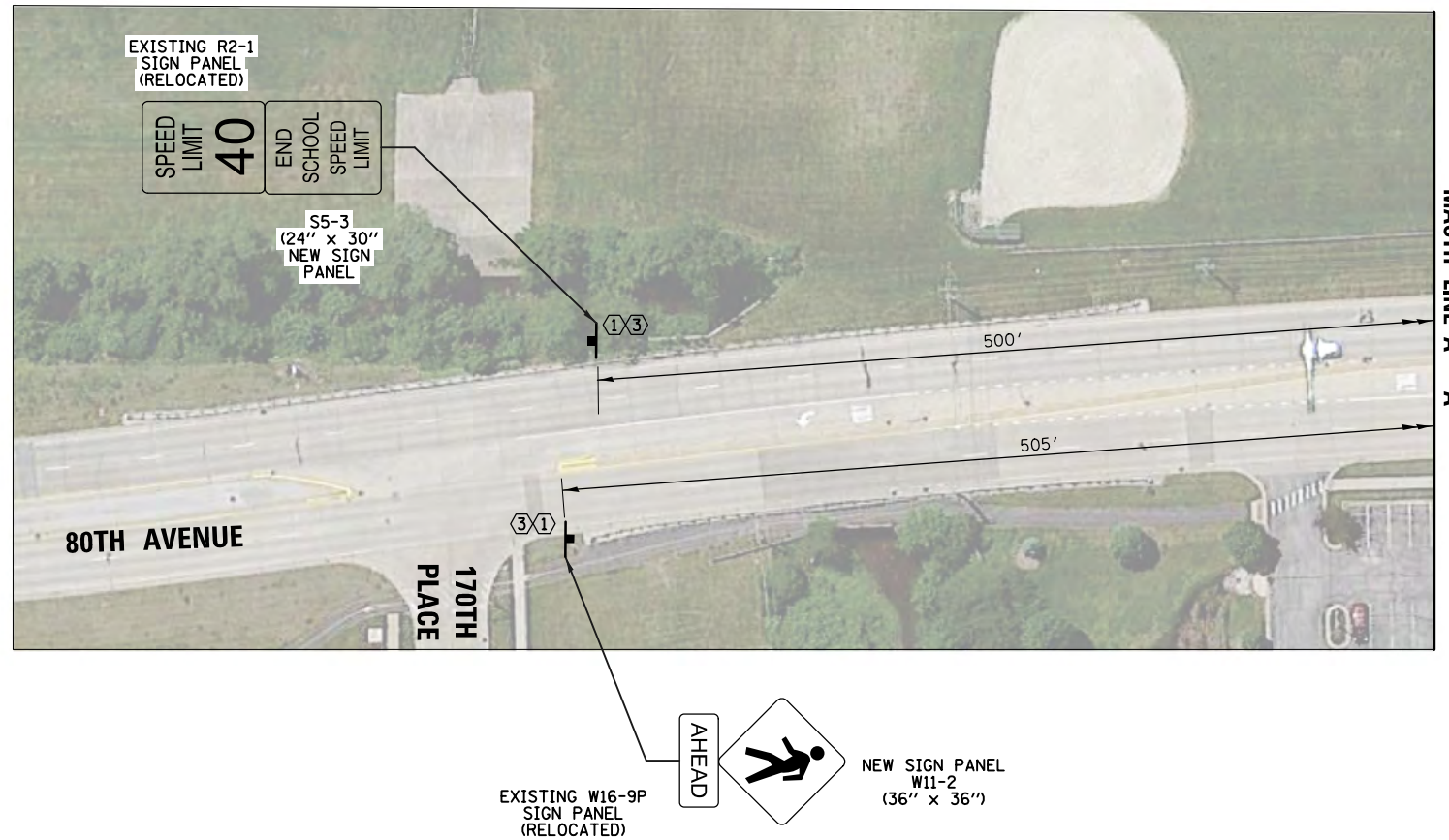
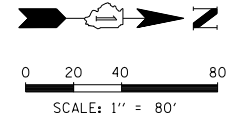

NOTE:

- 1. PROPOSED MUTCD SIGNS, W16-9P AND W11-2, SHALL HAVE A FLUORESCENT YELLOW-GREEN BACKGROUND.

RESTORATION OF WORK AREA. RESTORATION OF THE FLASHING BEACON WORK AREA SHALL BE INCIDENTAL TO THE RELATED PAY ITEM SUCH AS FOUNDATION AND NO EXTRA COMPENSATION SHALL BE ALLOWED. ALL ROADWAY SURFACES SUCH AS SHOULDERS, MEDIANS, SIDEWALKS, PAVEMENT, ETC. SHALL BE REPLACED IN KIND. ALL DAMAGE TO MOWED LAWNS SHALL BE REPLACED WITH AN APPROVED SOD, AND ALL DAMAGE TO UNMOWED FIELDS SHALL BE SEEDING IN ACCORDANCE WITH STANDARD SPECIFICATIONS 252 AND 250 RESPECTIVELY.

CHRISTOPHER B. BURKE ENGINEERING, LTD.
 9575 W. Higgins Road, Suite 600
 Rosemont, Illinois 60018
 (847) 823-0500

CLIENT:
VILLAGE OF TINLEY PARK
16250 OAK PARK AVENUE
TINLEY PARK, IL 60477

NO.	DATE	NATURE OF REVISION	CHKD.	MODEL:
FILE NAME	N:\TINLEY\160373\160373.00028\Traffic\05_PED_160373-028.dgn			

TITLE:
FLASHING BEACON INSTALLATION AND SIGNING PLAN
 (SHEET 1 OF 2)
80TH AVENUE FROM 167TH STREET TO 169TH STREET
TINLEY PARK, ILLINOIS

PROJ. NO. 160373.00028
 DATE: 3/3/2022
 SHEET 4 OF 21
 DRAWING NO.

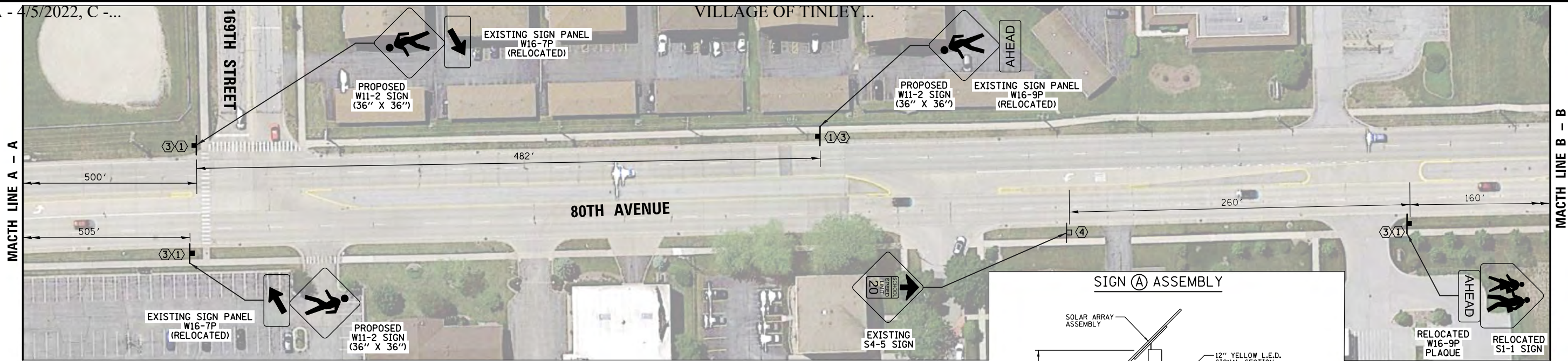

CONSTRUCTION NOTES:

- 1 THE CONTRACTOR SHALL RELOCATE THE EXISTING SIGN PANEL AND/OR INSTALL A NEW SIGN PANEL ON THE PROPOSED TELESCOPING STEEL SIGN SUPPORT.
- 2 THE FLASHING BEACON ASSEMBLIES SHALL BE PROGRAMMED TO OPERATE FROM 8:15 A.M. TO 8:45 A.M. AND FROM 3:15 P.M. TO 3:45 P.M., MONDAY THROUGH FRIDAY DURING THE SCHOOL YEAR AND HAVE A HOLIDAY SCHEDULE PROGRAMMED AS WELL. THE CONTRACTOR SHALL COORDINATE WITH THE VILLAGE FOR PROGRAMMING APPROVAL OF THE FLASHERS.
- 3 ALL SIGNS INSTALLED ON TELESCOPING STEEL SUPPORTS SHALL BE OFFSET 2' FROM FACE OF CURB TO EDGE OF SIGN IN ACCORDANCE WITH IDOT HIGHWAY STANDARD 720006. FLASHING BEACON CONCRETE FOUNDATIONS SHALL BE OFFSET 4' FROM BACK OF CURB TO CENTER OF FOUNDATION IN ACCORDANCE WITH IDOT D1 DETAIL TS-05.
- 4 EXISTING SIGNS AND EXISTING SIGN POST SHALL REMAIN.

NOTE:

1. PROPOSED MUTCD SIGNS, W16-9P AND W11-2, SHALL HAVE A FLUORESCENT YELLOW-GREEN BACKGROUND.

RESTORATION OF WORK AREA. RESTORATION OF THE FLASHING BEACON WORK AREA SHALL BE INCIDENTAL TO THE RELATED PAY ITEM SUCH AS FOUNDATION AND NO EXTRA COMPENSATION SHALL BE ALLOWED. ALL ROADWAY SURFACES SUCH AS SHOULDERS, MEDIANS, SIDEWALKS, PAVEMENT, ETC. SHALL BE REPLACED IN KIND. ALL DAMAGE TO MOWED LAWNS SHALL BE REPLACED WITH AN APPROVED SOD, AND ALL DAMAGE TO UNMOWED FIELDS SHALL BE SEEDED IN ACCORDANCE WITH STANDARD SPECIFICATIONS 252 AND 250 RESPECTIVELY.

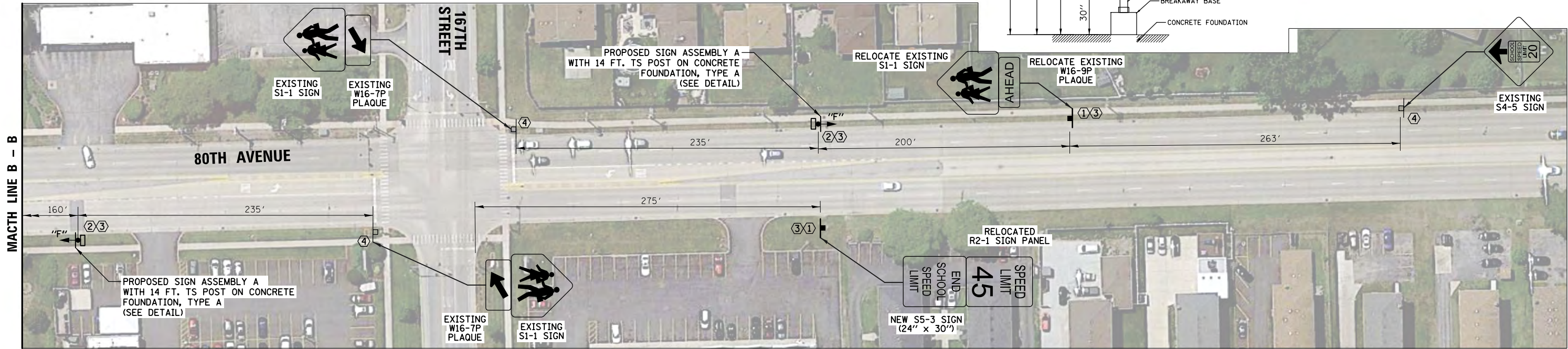
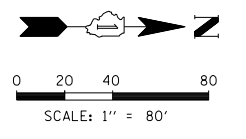
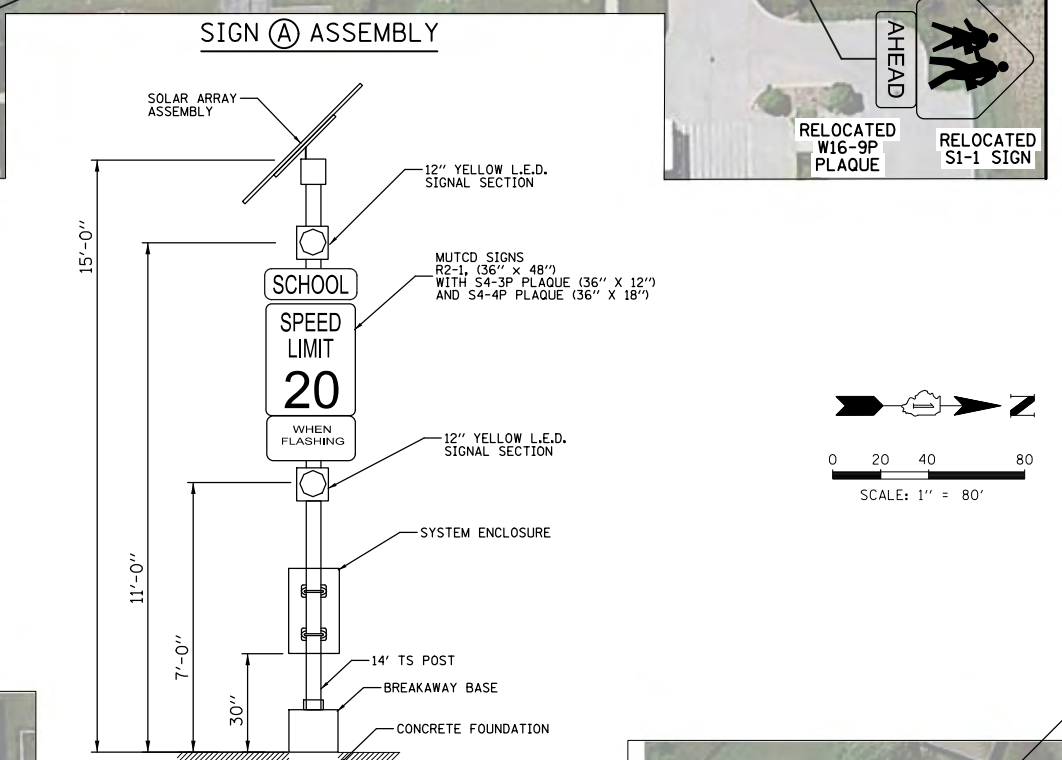

CHRISTOPHER B. BURKE ENGINEERING, LTD.
9575 W. Higgins Road, Suite 600
Rosemont, Illinois 60018
(847) 823-0500

CLIENT:
VILLAGE OF TINLEY PARK
16250 OAK PARK AVENUE
TINLEY PARK, IL 60477

NO.	DATE	NATURE OF REVISION	CHKD.	MODEL:

DSGN.	EAJ
DWN.	BG
CHKD.	GMZ
SCALE:	1" = 80'
PLOT DATE:	3/13/2022
CAD USER:	eJensen
FILE NAME	\\N\tINLEYPARK\60373\60373.00028\Ttraffic\06_PED2\60373-028.dgn

TITLE:
FLASHING BEACON INSTALLATION AND SIGNING PLAN
(SHEET 2 OF 2)
80TH AVENUE FROM 167TH STREET TO 169TH STREET
TINLEY PARK, ILLINOIS

PROJ. NO. 160373.00028
DATE: 3/3/2022
SHEET 5 OF 21
DRAWING NO.

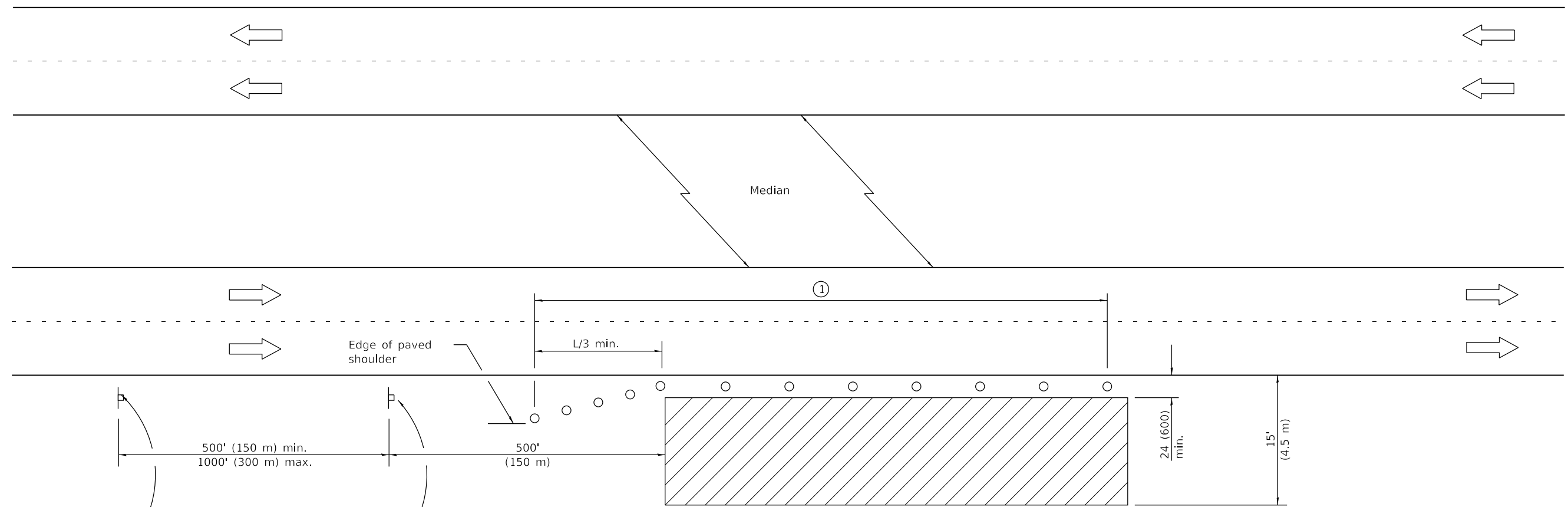

For contract construction projects



W20-1103(0)-48



W21-1(0)-48

For maintenance and utility projects



W20-1(0)-48

TYPICAL APPLICATIONS

- Utility operations
- Culvert extensions
- Side slope changes
- Guardrail installation and maintenance
- Delineator installation
- Landscaping operations
- Shoulder repair
- Sign installation and maintenance

① When the work operation exceeds one hour, cones, drums or barricades shall be placed at 25' (8 m) centers for L/3 distance, and at 50' (15 m) centers through the remainder of the work area.

SYMBOLS

- Work area
- Sign
- Cone, drum or barricade

GENERAL NOTES

This Standard is used where any vehicles, equipment, workers or their activities will encroach in the area 15' (4.5 m) to 24' (600) from the edge of pavement.

Calculate L as follows:

SPEED LIMIT	FORMULAS	
	English	(Metric)
40 mph (70 km/h) or less:	$L = \frac{WS^2}{60}$	$L = \frac{WS^2}{150}$
45 mph (80 km/h) or greater:	$L = (W)(S)$	$L = 0.65(W)(S)$

W = Width of offset in feet (meters).

S = Normal posted speed mph (km/h).

All dimensions are in inches (millimeters) unless otherwise shown.

DATE	REVISIONS
4-1-16	Corrected typo in title.
1-1-14	Revised workers sign number to agree with current MUTCD.

OFF-RD OPERATIONS, MULTILANE, 15' (4.5 m) TO 24" (600 mm) FROM PAVEMENT EDGE

STANDARD 701101-05

Illinois Department of Transportation

PASSED April 1, 2016

 ENGINEER OF SAFETY ENGINEERING

APPROVED April 1, 2016

 ENGINEER OF DESIGN AND ENVIRONMENT

ISSUED 1-1-97

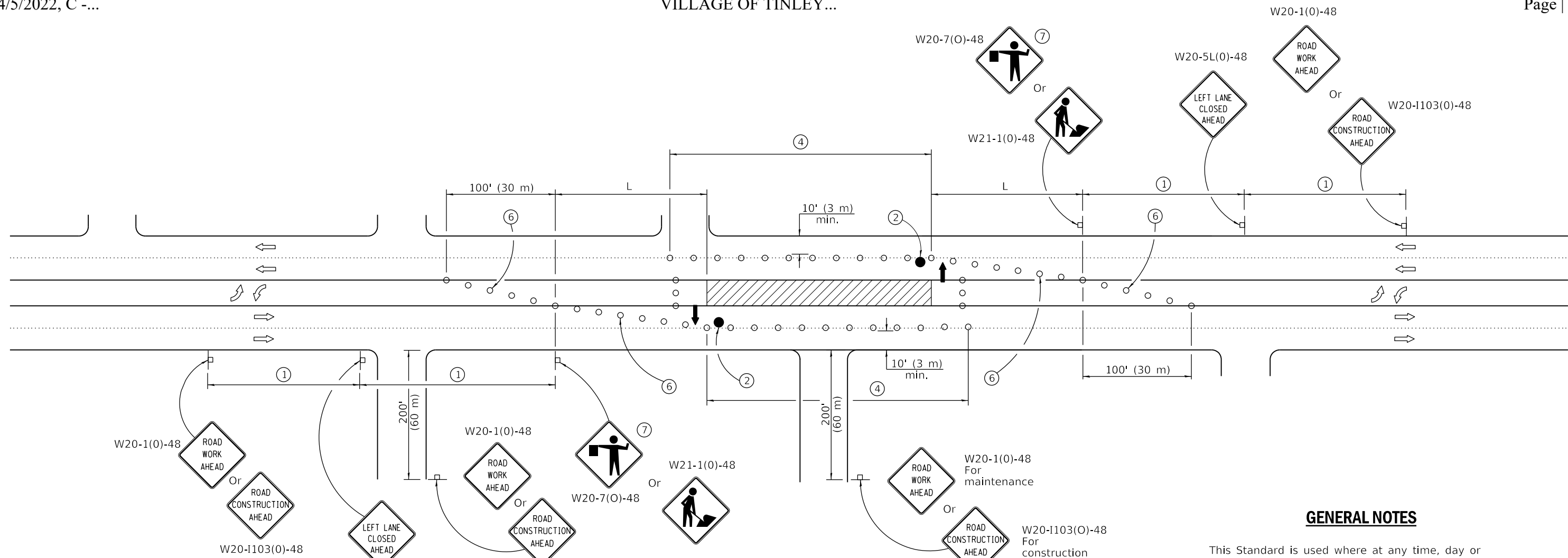

SIGN SPACING	
Posted Speed	Sign Spacing
55	500' (150 m)
50-45	350' (100 m)
<45	200' (60 m)

- SYMBOLS**
- Arrow board
 - Work area
 - Barricade or drum with steady burning mondirectional light
 - Flagger with traffic control sign
 - Cone, drum or barricade
 - Sign on portable or permanent support
 - Type III barricade with flashing lights

CASE I

- ① Refer to SIGN SPACING TABLE for distances.
- ② Required for speeds > 40 mph (70 km/h).
- ③ Required if work exceeds 500' (164 m) or 1 block, repeat every 1 mile (1.6 km).
- ④ Cones at 25' (8 m) centers for 250' (75 m) on approach. Additional cones may be placed at 50' (15 m) centers. When drums or type I or II barricades are used, the interval between devices may be doubled.
- ⑤ For approved sideroad closures.
- ⑥ Cones, drums or barricades at 20' (6 m) centers in taper.
- ⑦ Use flagger sign only when flagger is present.

GENERAL NOTES

This Standard is used where at any time, day or night, any vehicle, equipment, workers or their activities encroach on the pavement requiring the closure of one traffic lane in an Urban area.

If the work operation is performed between 9:00 a.m. and 3:00 p.m. and does not exceed 15 min. Traffic protection shall be as shown for Standard 701426.

Calculate L as follows:

SPEED LIMIT	FORMULAS	
	English	(Metric)
40 mph (70 km/h) or less:	$L = \frac{WS^2}{60}$	$L = \frac{WS^2}{150}$
45 mph (80 km/h) or greater:	$L=(W)(S)$	$L=0.65(W)(S)$

W = Width of offset in feet (meters).
 S = Normal posted speed mph (km/h).

All dimensions are in inches (millimeters) unless otherwise shown.

DATE	REVISIONS
1-1-19	Revised to allow cones at night.
1-1-18	Moved arrow boards into closed lanes for CASE I.

**URBAN LANE CLOSURE,
MULTILANE, 2W WITH
BIDIRECTIONAL LEFT TURN LANE**

(Sheet 1 of 4)

STANDARD 701602-10

Illinois Department of Transportation

APPROVED January 1, 2019

 ENGINEER OF SAFETY PROG. AND ENGINEERING

APPROVED January 1, 2019

 ENGINEER OF DESIGN AND ENVIRONMENT

ISSUED 1-1-13

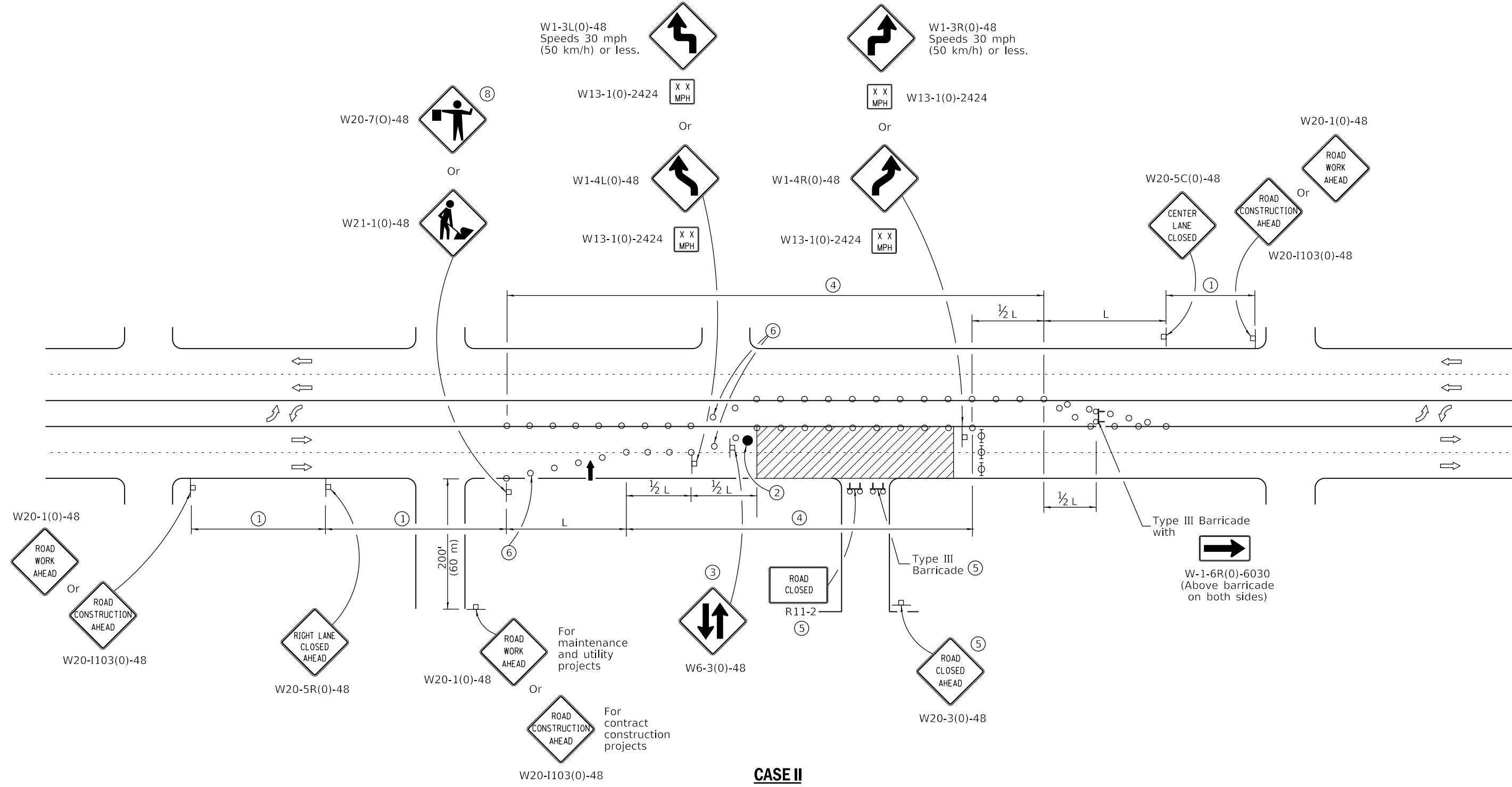

CASE II

Illinois Department of Transportation

APPROVED January 1, 2019
Cynthia Watt
 ENGINEER OF SAFETY PROG. AND ENGINEERING

APPROVED January 1, 2019
J. E. ...
 ENGINEER OF DESIGN AND ENVIRONMENT

ISSUED 1-1-13

**URBAN LANE CLOSURE,
 MULTILANE, 2W WITH
 BIDIRECTIONAL LEFT TURN LANE**

(Sheet 2 of 4)

STANDARD 701602-10

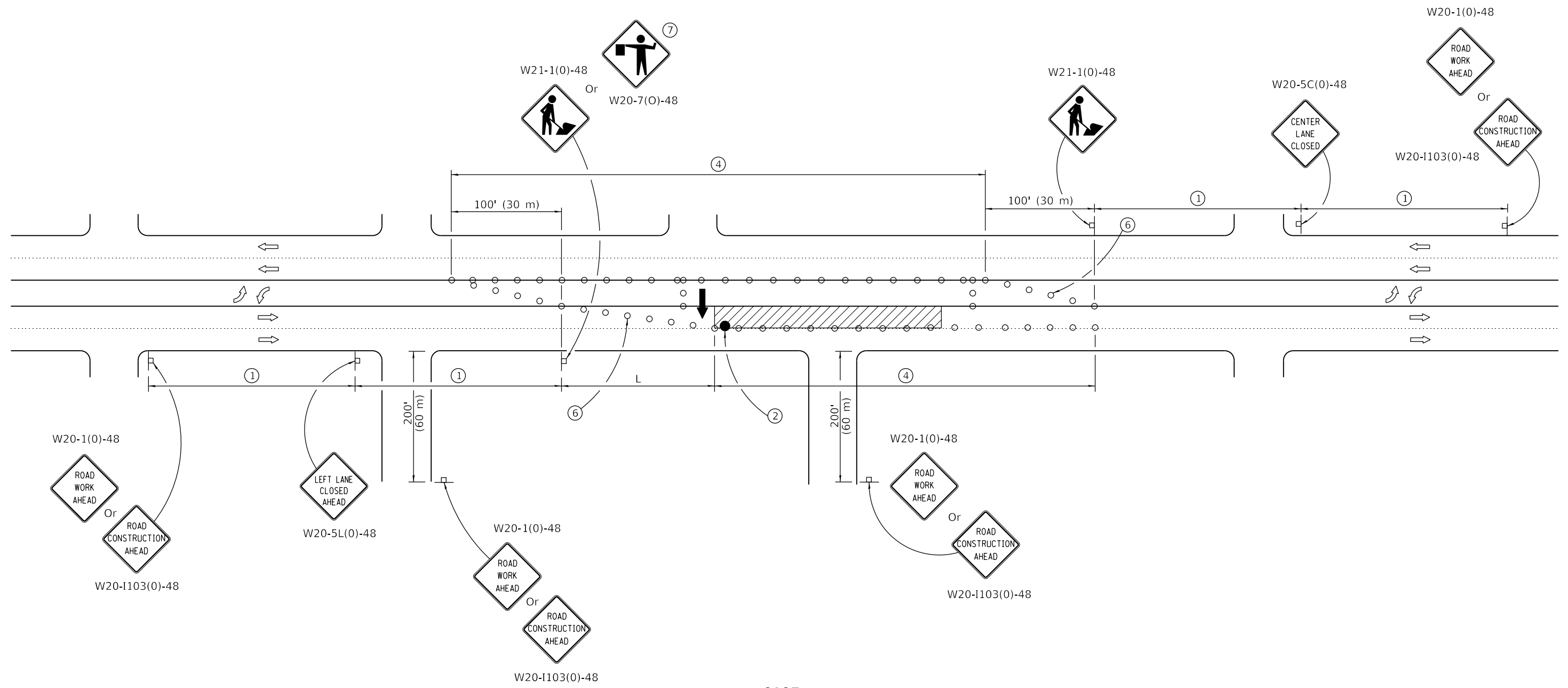

CASE III

Illinois Department of Transportation

APPROVED January 1, 2019
Cynthia Watt
 ENGINEER OF SAFETY PROG. AND ENGINEERING

APPROVED January 1, 2019
J. E. ...
 ENGINEER OF DESIGN AND ENVIRONMENT

ISSUED 1-1-13

**URBAN LANE CLOSURE,
 MULTILANE, 2W WITH
 BIDIRECTIONAL LEFT TURN LANE**

(Sheet 3 of 4)

STANDARD 701602-10

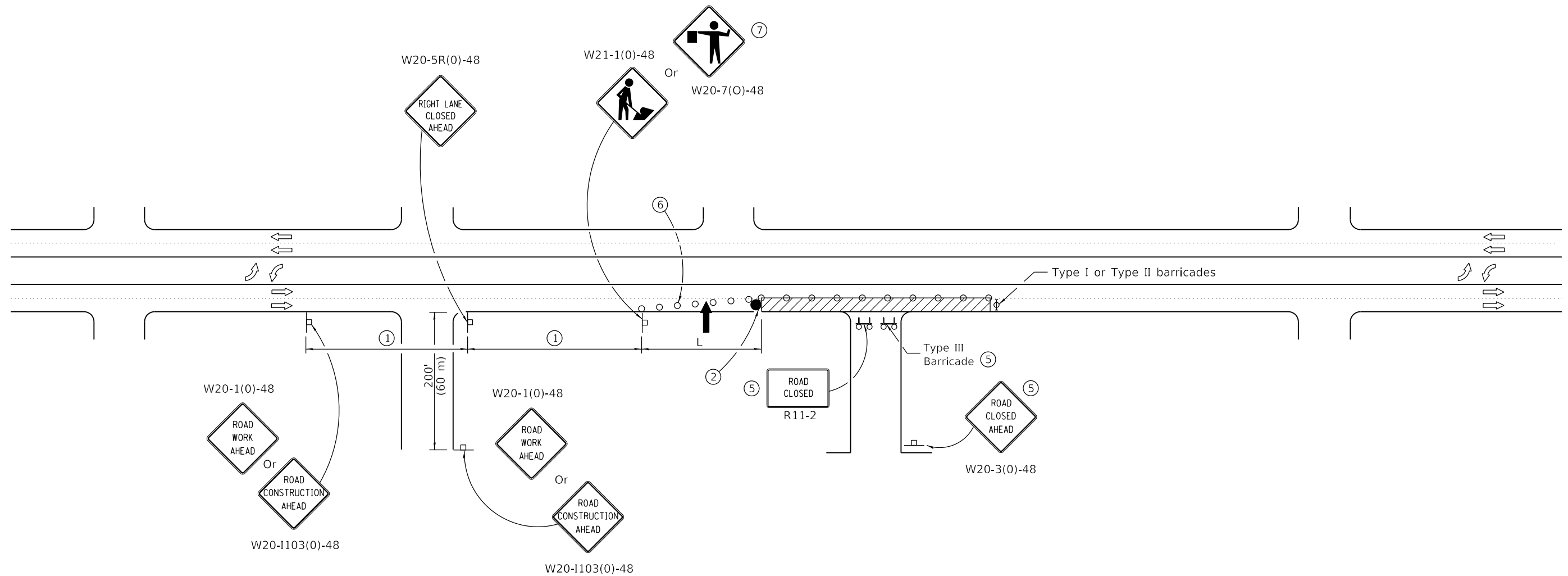

CASE IV

Illinois Department of Transportation

APPROVED January 1, 2019
Cynthia Watt
 ENGINEER OF SAFETY PROG. AND ENGINEERING

ISSUED 1-1-13

APPROVED January 1, 2019
J. E. ...
 ENGINEER OF DESIGN AND ENVIRONMENT

**URBAN LANE CLOSURE,
 MULTILANE, 2W WITH
 BIDIRECTIONAL LEFT TURN LANE**

(Sheet 4 of 4)

STANDARD 701602-10

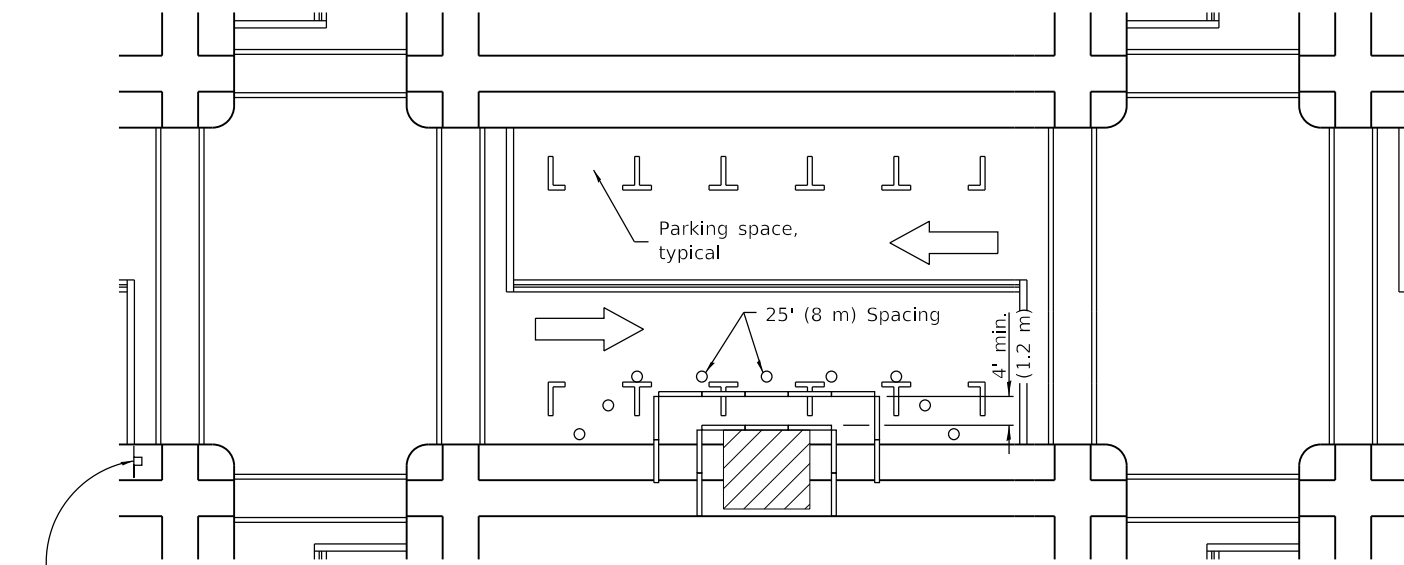

① ROAD CONSTRUCTION AHEAD
W20-1103(0)-48 for contract construction projects

Or
① ROAD WORK AHEAD
W20-1(0)-48 for maintenance and utility projects

SIDEWALK DIVERSION

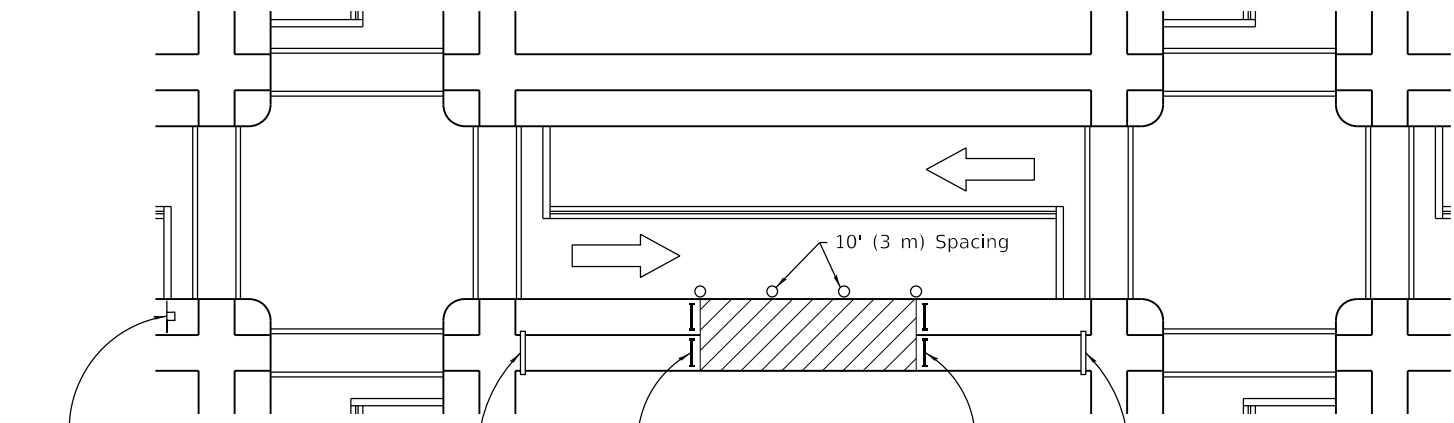

① ROAD CONSTRUCTION AHEAD
W20-1103(0)-48 for contract construction projects

Or
① ROAD WORK AHEAD
W20-1(0)-48 for maintenance and utility projects

SIDEWALK CLOSED
←
USE OTHER SIDE
R11-1102-2430

SIDEWALK CLOSED
R11-1101-2418

SIDEWALK CLOSED
→
USE OTHER SIDE
R11-1102-2430

SIDEWALK CLOSURE

① Omit whenever duplicated by road work traffic control.

SYMBOLS

- Work area
- Sign on portable or permanent support
- Barricade or drum
- Cone, drum or barricade
- Type III barricade
- Detectable pedestrian channelizing barricade

GENERAL NOTES

This Standard is used where, at any time, pedestrian traffic must be rerouted due to work being performed.

This Standard must be used in conjunction with other Traffic Control & Protection Standards when roadway traffic is affected.

Temporary facilities shall be detectable and accessible.

The temporary pedestrian facilities shall be provided on the same side of the closed facilities whenever possible.

The SIDEWALK CLOSED / USE OTHER SIDE sign shall be placed at the nearest crosswalk or intersection to each end of the closure. Where the closure occurs at a corner, the signs shall be erected on the corners across the street from the closure. The SIDEWALK CLOSED signs shall be used at the ends of the actual closures.

Type III barricades and R11-2-4830 signs shall be positioned as shown in "ROAD CLOSED TO ALL TRAFFIC" detail on Standard 701901.

All dimensions are in inches (millimeters) unless otherwise shown.

DATE	REVISIONS
4-1-16	Omitted orange safety fence from standard as this is covered in the std. spec.
1-1-12	Added SIDEWALK DIVERSION. Modified appearance of plan views. Renamed Std.

SIDEWALK, CORNER OR CROSSWALK CLOSURE

(Sheet 1 of 2)

STANDARD 701801-06

Illinois Department of Transportation

PASSED April 1, 2016

[Signature]
ENGINEER OF SAFETY ENGINEERING

APPROVED April 1, 2016

[Signature]
ENGINEER OF DESIGN AND ENVIRONMENT

ISSUED 1-1-97

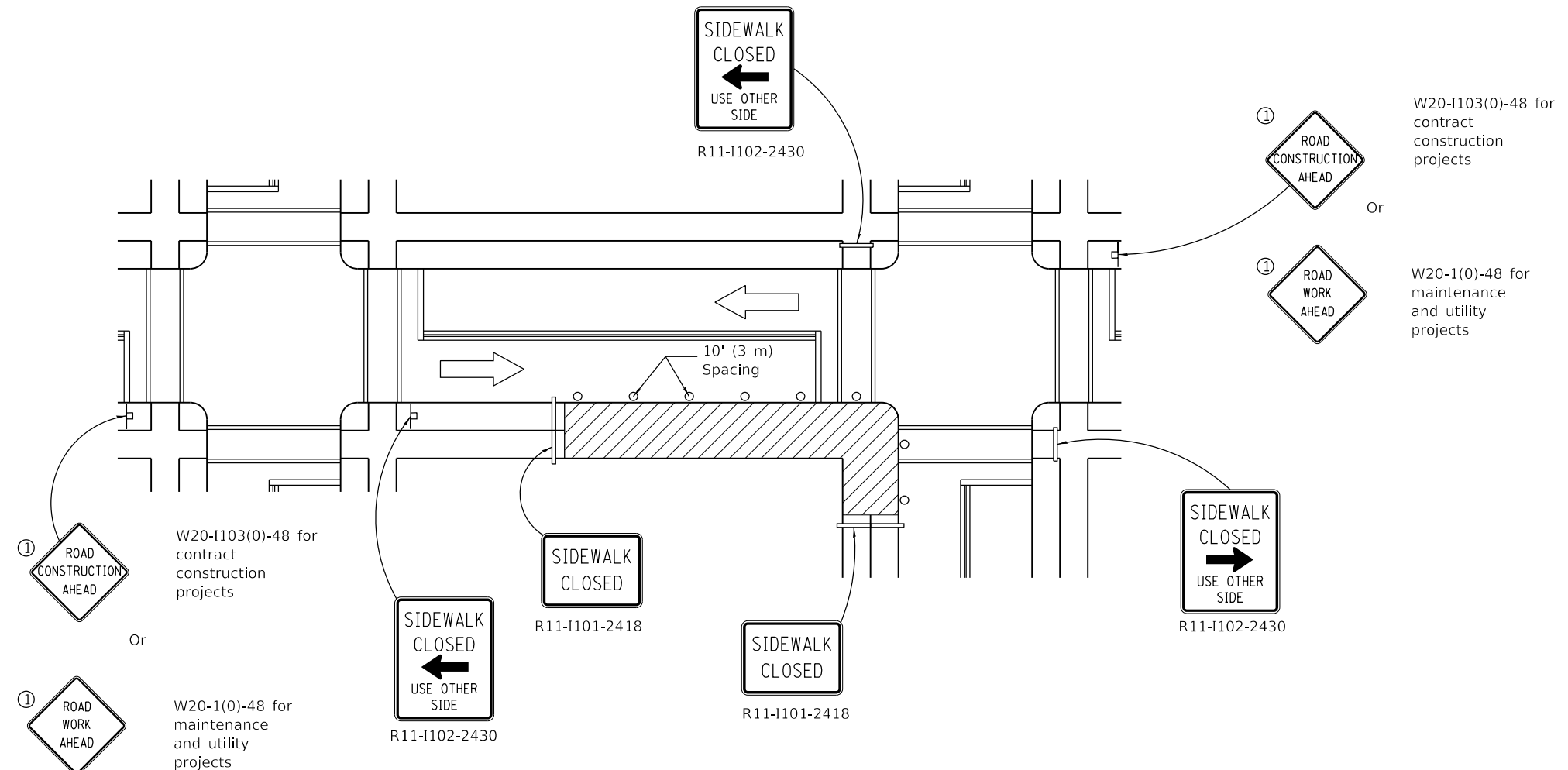

CORNER CLOSURE

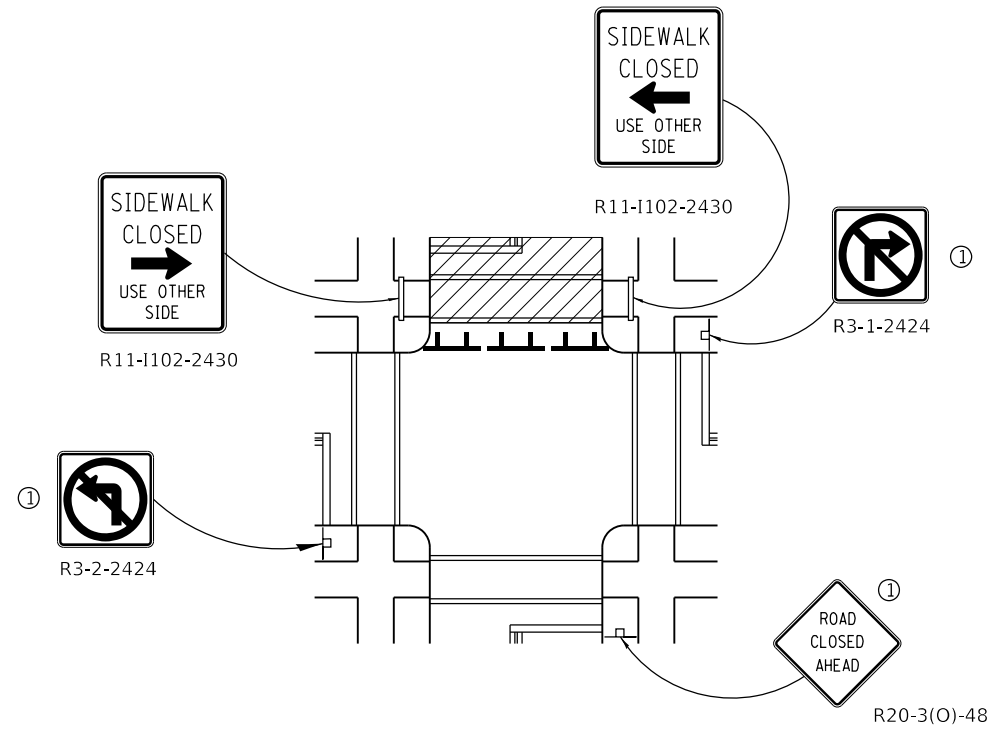

CROSSWALK CLOSURE

SIDEWALK, CORNER OR CROSSWALK CLOSURE
 (Sheet 2 of 2)
STANDARD 701801-06

Illinois Department of Transportation

PASSED April 1, 2016
 ENGINEER OF SAFETY ENGINEERING

APPROVED April 1, 2016
 ENGINEER OF DESIGN AND ENVIRONMENT

ISSUED 1-1-97

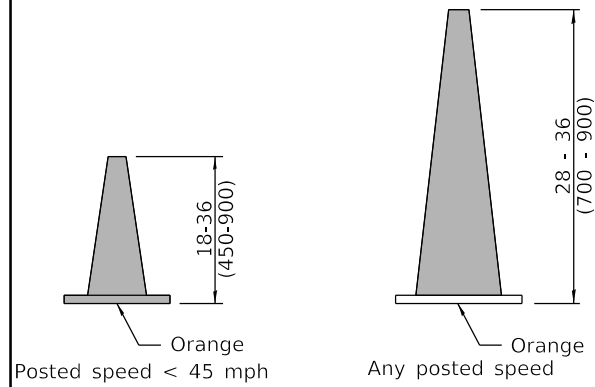

DAYTIME USE

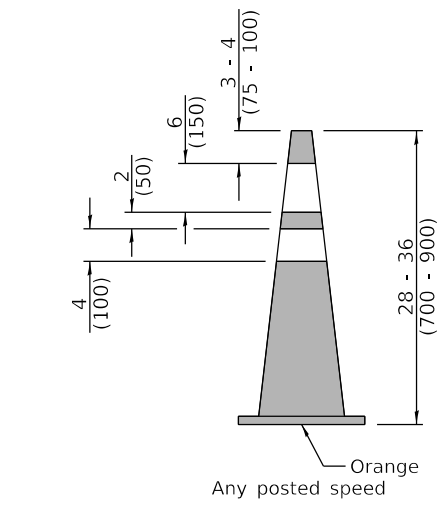

DAY OR NIGHTTIME USE

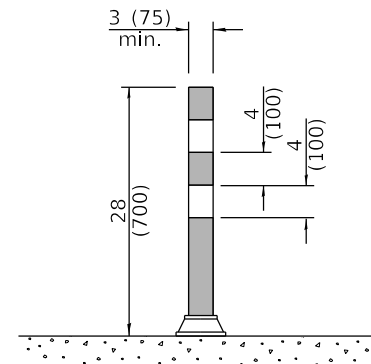
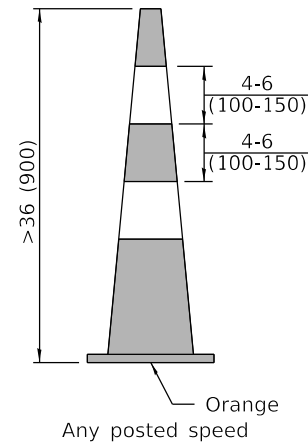

TUBULAR MARKER

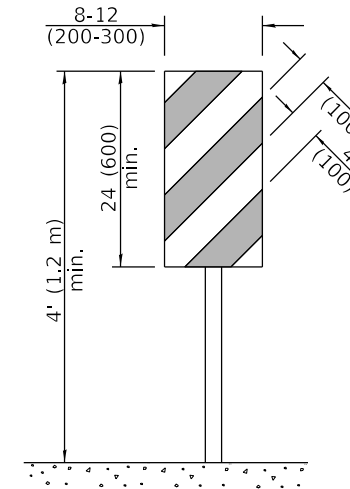

**VERTICAL PANEL
POST MOUNTED**

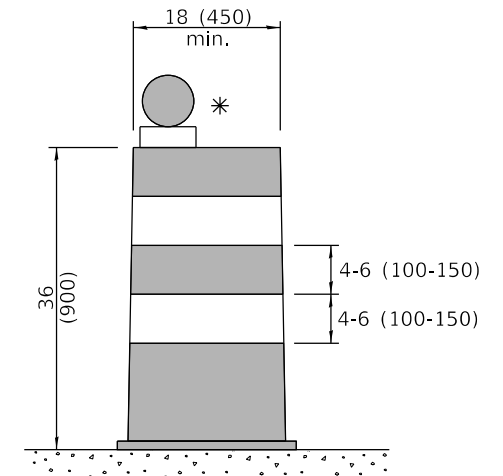

DRUM

CONES

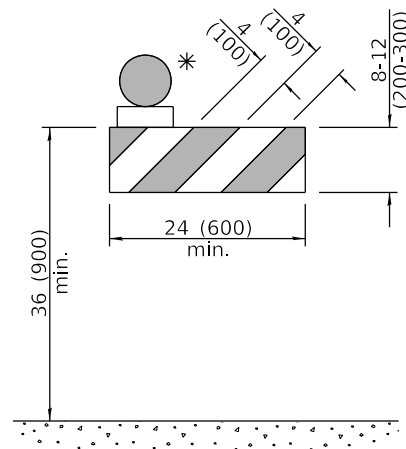

TYPE I BARRICADE

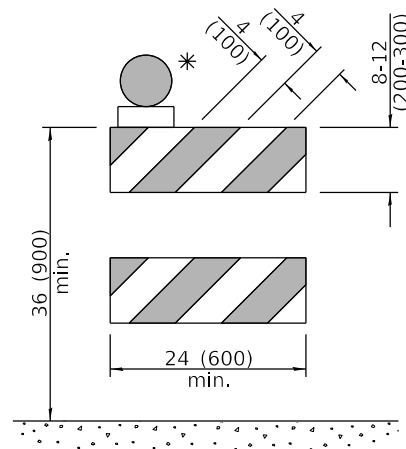

TYPE II BARRICADE

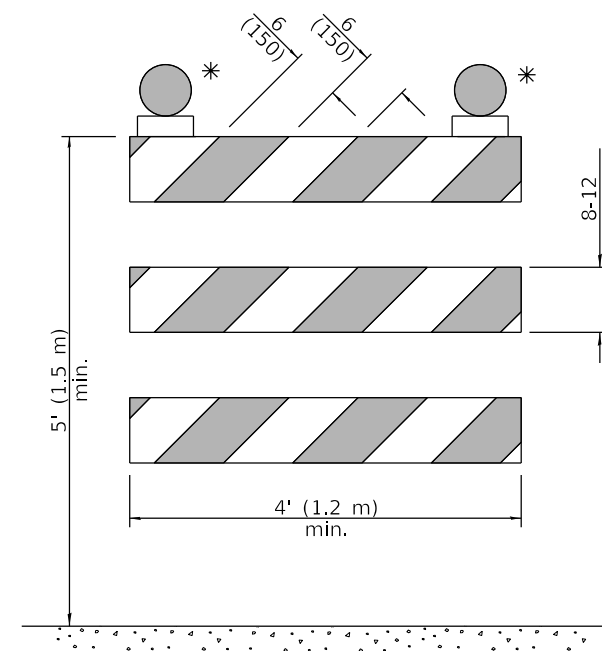

TYPE III BARRICADE

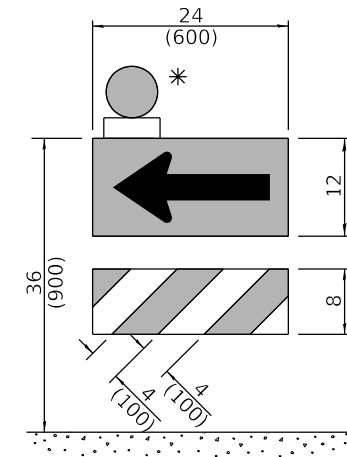

**DIRECTION INDICATOR
BARRICADE**

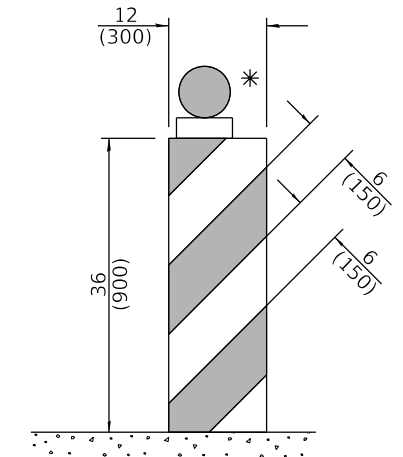

VERTICAL BARRICADE

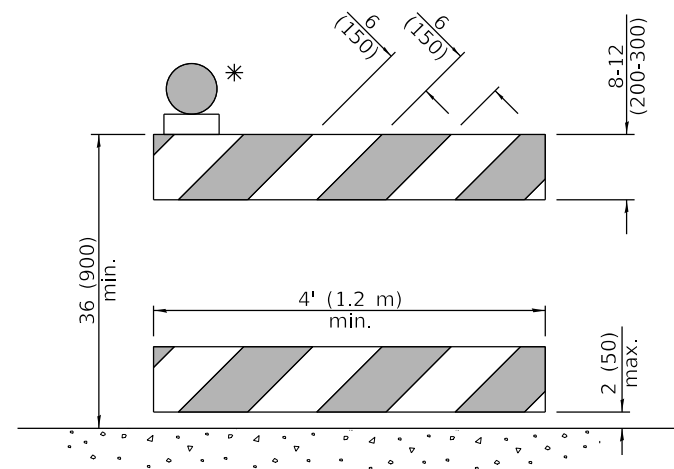

**DETECTABLE PEDESTRIAN
CHANNELIZING BARRICADE**

* Warning lights (if required)

GENERAL NOTES

All heights shown shall be measured above the pavement surface.

All dimensions are in inches (millimeters) unless otherwise shown.

DATE	REVISIONS
1-1-19	Revised cone usage and added cones >36" (900 m) height.
1-1-18	Revised END WORK ZONE SPEED LIMIT sign from orange to white background.

TRAFFIC CONTROL DEVICES

(Sheet 1 of 3)

STANDARD 701901-08

Illinois Department of Transportation

APPROVED January 1, 2019
Cynthia Watt
 ENGINEER OF SAFETY PROG. AND ENGINEERING

APPROVED January 1, 2019
Joe E. ...
 ENGINEER OF DESIGN AND ENVIRONMENT

ISSUED
 ET-1-1

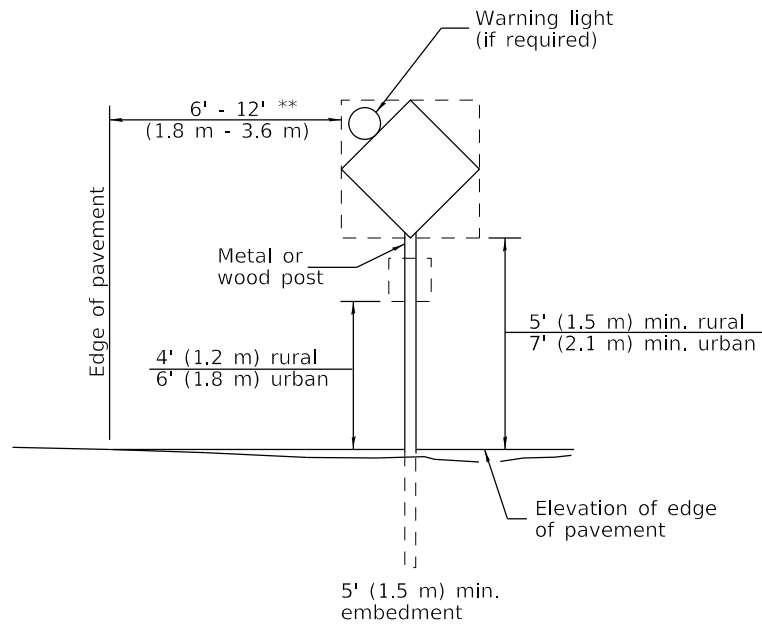

POST MOUNTED SIGNS

** When curb or paved shoulder are present this dimension shall be 24 (600) to the face of curb or 6' (1.8 m) to the outside edge of the paved shoulder.

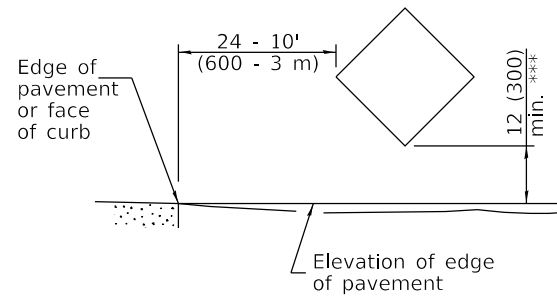

SIGNS ON TEMPORARY SUPPORTS

*** When work operations exceed four days, this dimension shall be 5' (1.5 m) min. If located behind other devices, the height shall be sufficient to be seen completely above the devices.

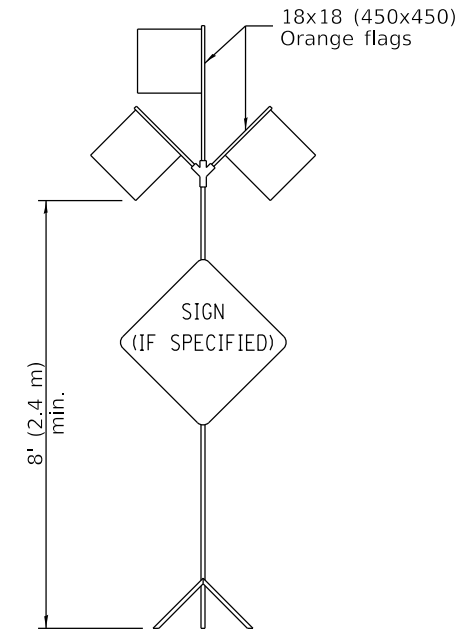

HIGH LEVEL WARNING DEVICE

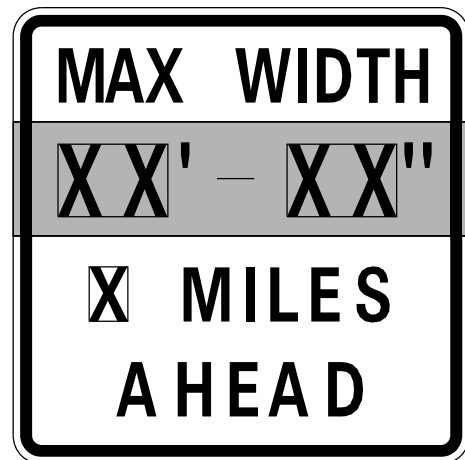

W12-I103-4848

WIDTH RESTRICTION SIGN

XX'-XX" width and X miles are variable.

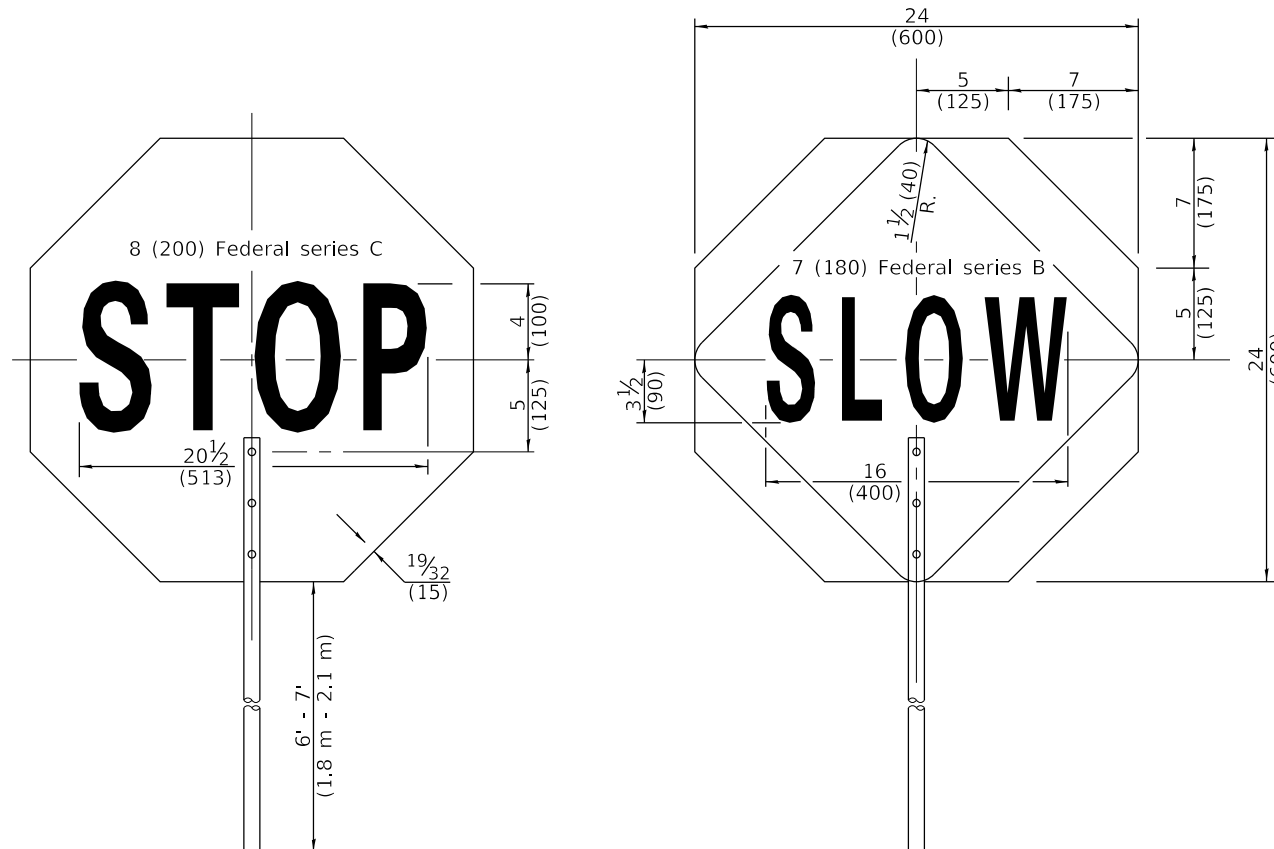

FRONT SIDE

REVERSE SIDE

FLAGGER TRAFFIC CONTROL SIGN

ROAD CONSTRUCTION NEXT X MILES	END CONSTRUCTION
G20-I104(0)-6036	G20-I105(0)-6024

This signing is required for all projects 2 miles (3200 m) or more in length.

ROAD CONSTRUCTION NEXT X MILES sign shall be placed 500' (150 m) in advance of project limits.

END CONSTRUCTION sign shall be erected at the end of the job unless another job is within 2 miles (3200 m).

Dual sign displays shall be utilized on multi-lane highways.

WORK LIMIT SIGNING

WORK ZONE	W21-III5(0)-3618
SPEED LIMIT XX	R2-1-3648
PHOTO ENFORCED	R10-I108p-3618 ****
\$XXX FINE MINIMUM	R2-I106p-3618

Sign assembly as shown on Standards or as allowed by District Operations.

END WORK ZONE SPEED LIMIT	G20-I103-6036
---------------------------	---------------

This sign shall be used when the above sign assembly is used.

HIGHWAY CONSTRUCTION SPEED ZONE SIGNS

**** R10-I108p shall only be used along roadways under the jurisdiction of the State.

TRAFFIC CONTROL DEVICES

(Sheet 2 of 3)

STANDARD 701901-08

Illinois Department of Transportation

APPROVED January 1, 2019
Cynthia Watt
 ENGINEER OF SAFETY PROG. AND ENGINEERING

APPROVED January 1, 2019
J. Ed. Cole
 ENGINEER OF DESIGN AND ENVIRONMENT

ISSUED 1-1-13

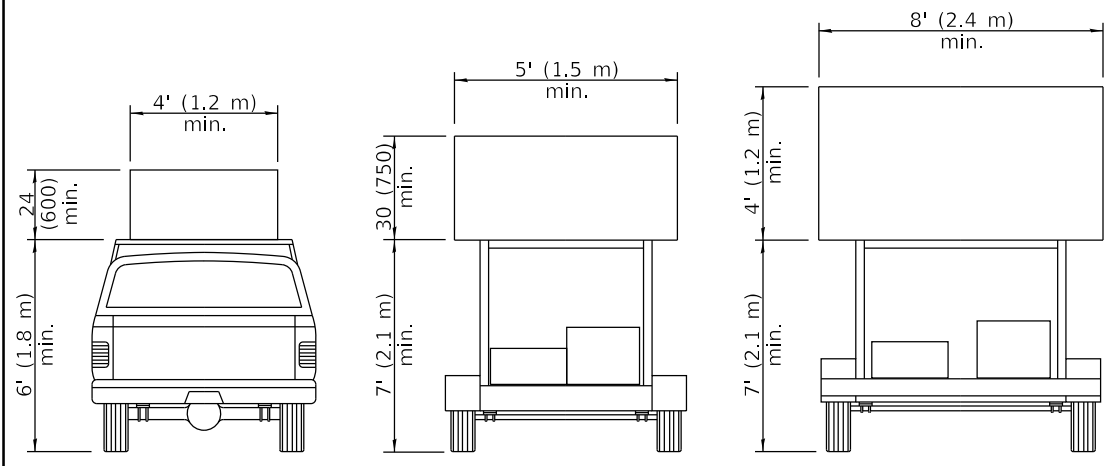

TYPE A ROOF MOUNTED
TYPE B ROOF OR TRAILER MOUNTED
TYPE C TRAILER MOUNTED

ARROW BOARDS

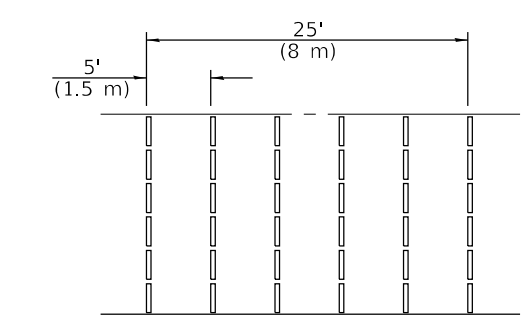
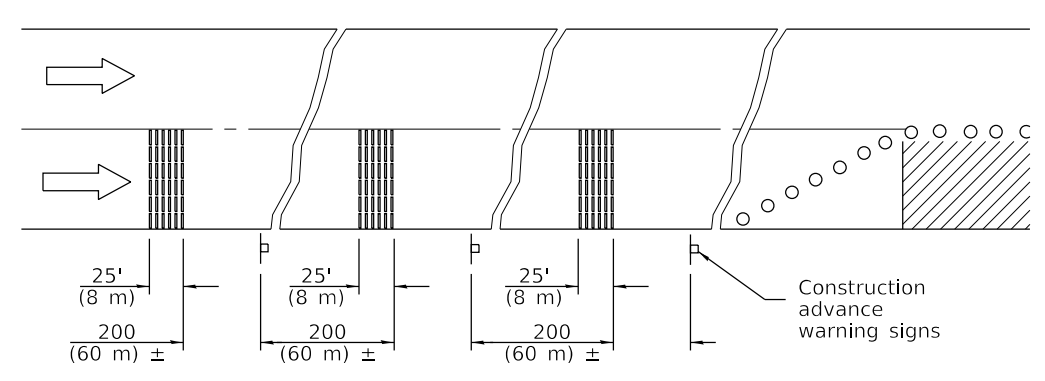
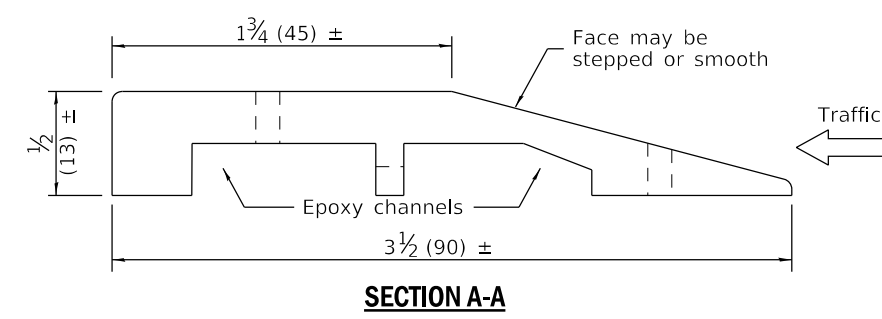
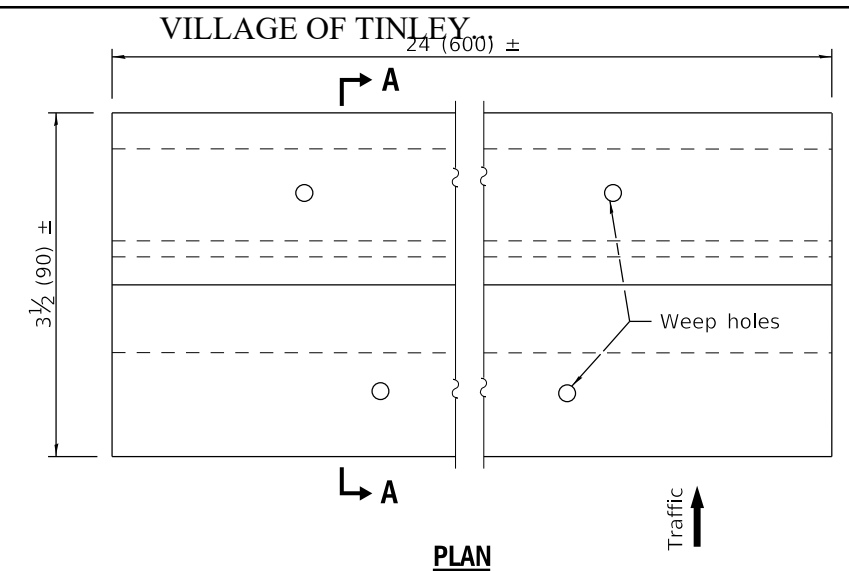

TEMPORARY RUMBLE STRIPS

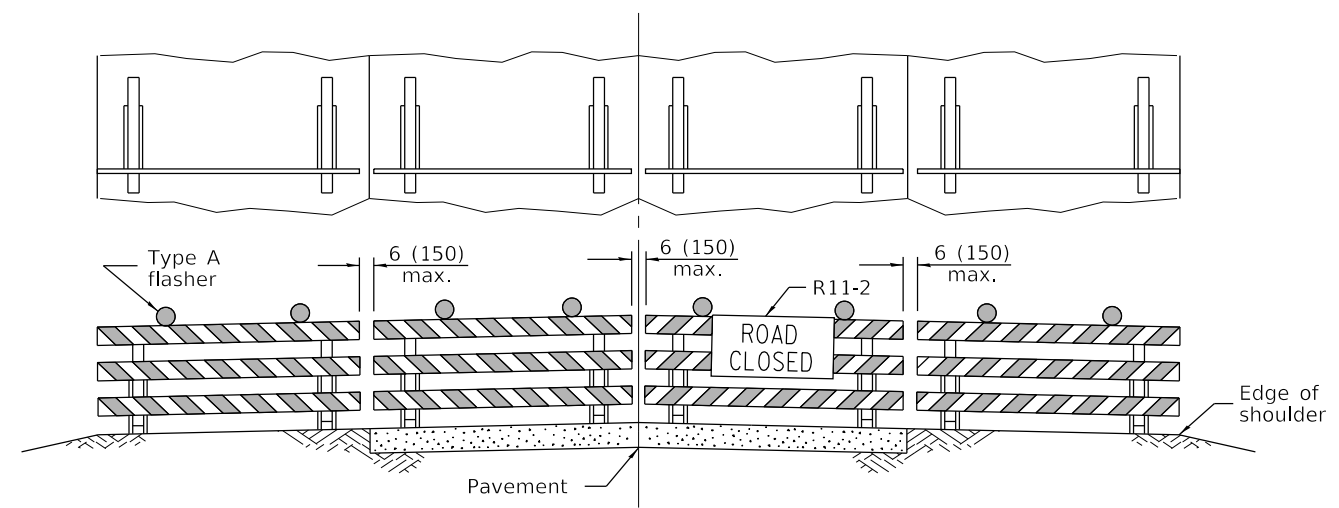

ROAD CLOSED TO ALL TRAFFIC

Reflectorized striping may be omitted on the back side of the barricades. If a Type III barricade with an attached sign panel which meets NCHRP 350 is not available, the sign may be mounted on an NCHRP 350 temporary sign support directly in front of the barricade.

TYPICAL APPLICATIONS OF TYPE III BARRICADES CLOSING A ROAD

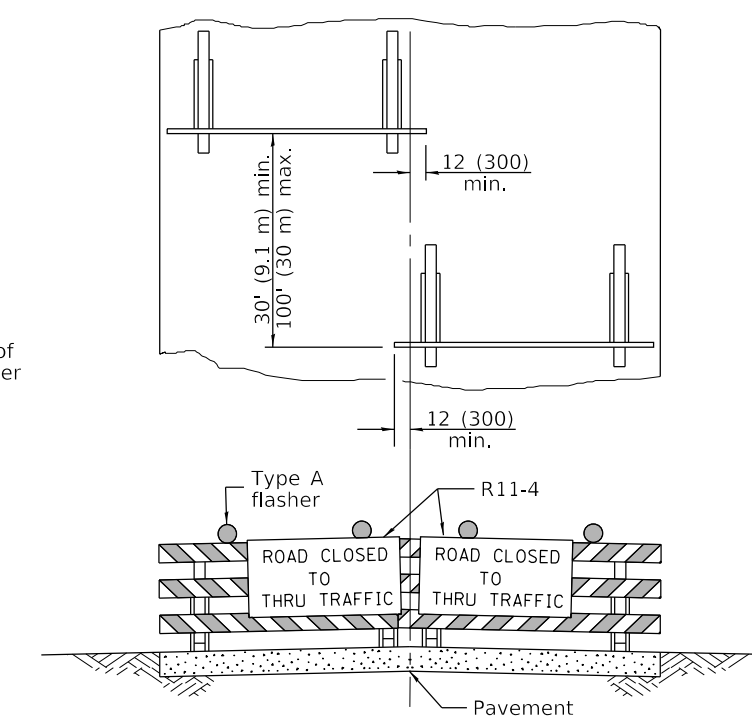

ROAD CLOSED TO THRU TRAFFIC

Reflectorized striping shall appear on both sides of the barricades. If a Type III barricade with an attached sign panel which meets NCHRP 350 is not available, the signs may be mounted on NCHRP 350 temporary sign supports directly in front of the barricade.

Illinois Department of Transportation

APPROVED January 1, 2019
Cynthia Watt
 ENGINEER OF SAFETY PROG. AND ENGINEERING

APPROVED January 1, 2019
Joe E. ...
 ENGINEER OF DESIGN AND ENVIRONMENT

ISSUES: E1-1-1

TRAFFIC CONTROL DEVICES

(Sheet 3 of 3)

STANDARD 701901-08

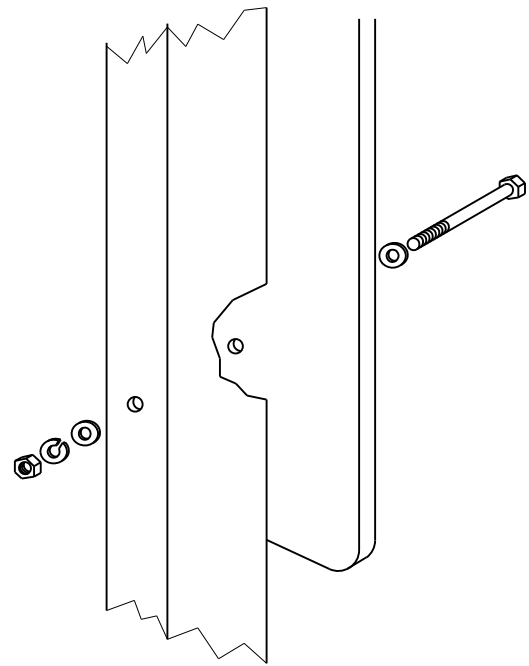

Sign panel 36 (900) wide or less

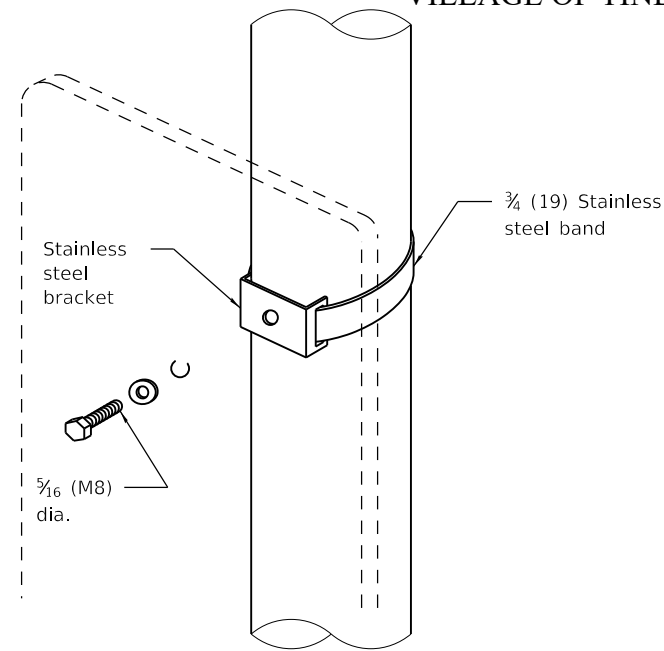

Sign panel 36 (900) wide or less

Section modulus (minimum)	Axis A	Axis B
Steel	0.050 in. ³ (819 mm ³)	0.105 in. ³ (1720 mm ³)
Aluminum	0.150 in. ³ (2458 mm ³)	0.315 in. ³ (5162 mm ³)

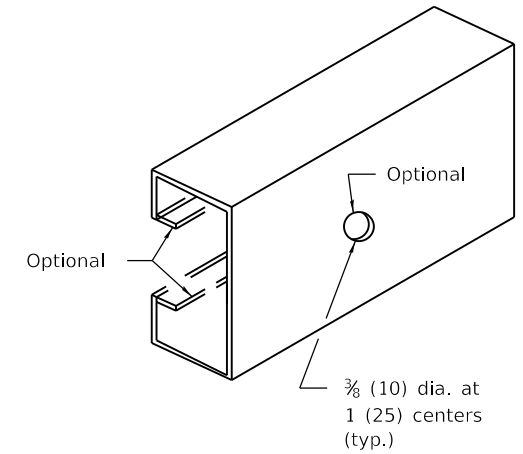
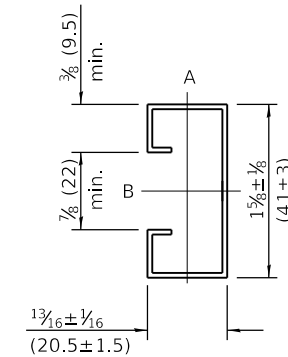

SUPPORTING CHANNEL DETAILS

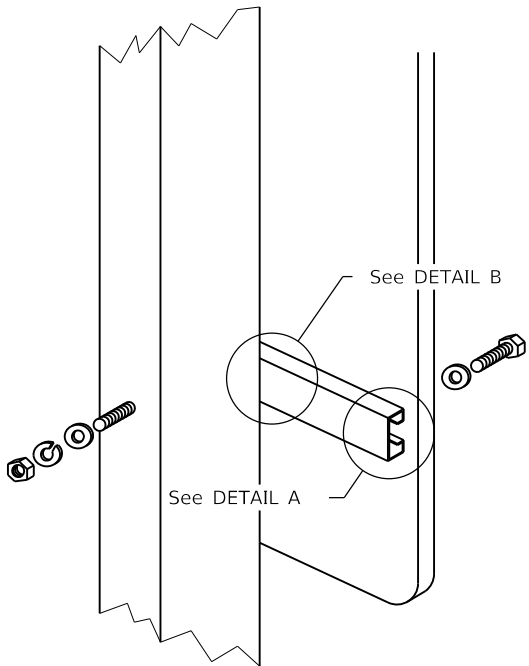

Sign panel over 36 (900) wide

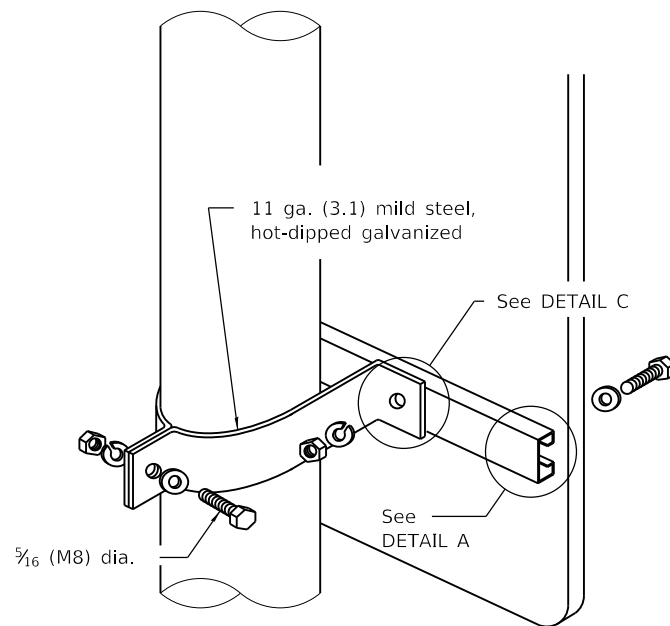

Sign panel over 36 (900) wide

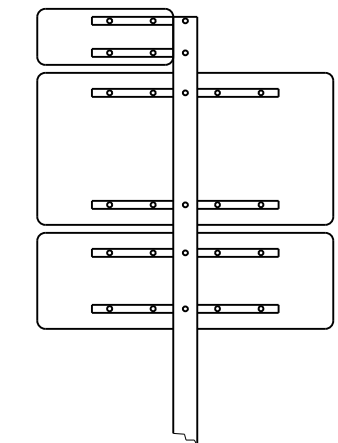
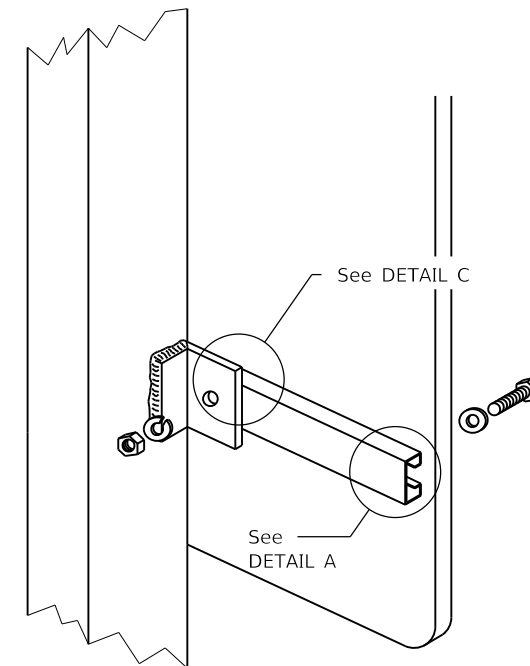

ROUTE MARKER ASSEMBLY

WOOD OR TELESCOPING STEEL POSTS

LIGHT OR SIGNAL STANDARDS

BREAKAWAY STEEL TUBING POSTS
(All sign panel sizes)

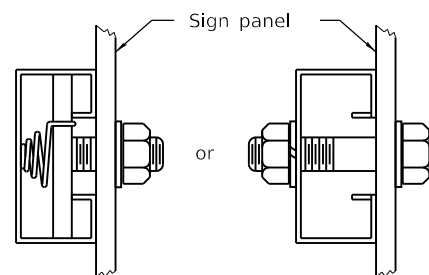

DETAIL A

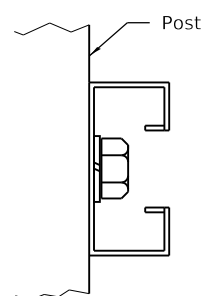

DETAIL B

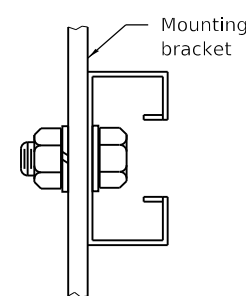

DETAIL C

All dimensions are in inches (millimeters) unless otherwise shown.

DATE	REVISIONS
1-1-09	Switched units to English (metric).
1-1-97	Renum. Standard 2319-6.

SIGN PANEL MOUNTING DETAILS

STANDARD 720001-01

Illinois Department of Transportation

PASSED January 1, 2009
[Signature]
ENGINEER OF OPERATIONS

APPROVED January 1, 2009
[Signature]
ENGINEER OF DESIGN AND ENVIRONMENT

ISSUED 1-1-97

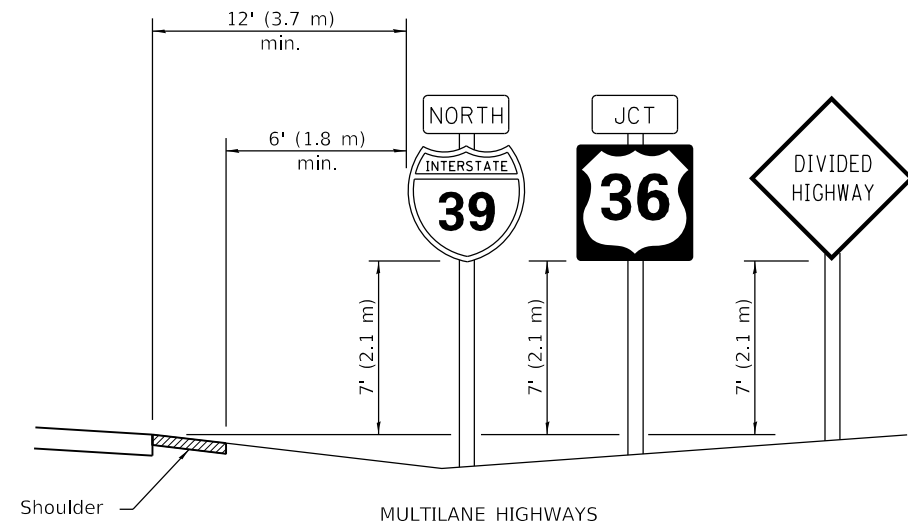

MULTILANE HIGHWAYS

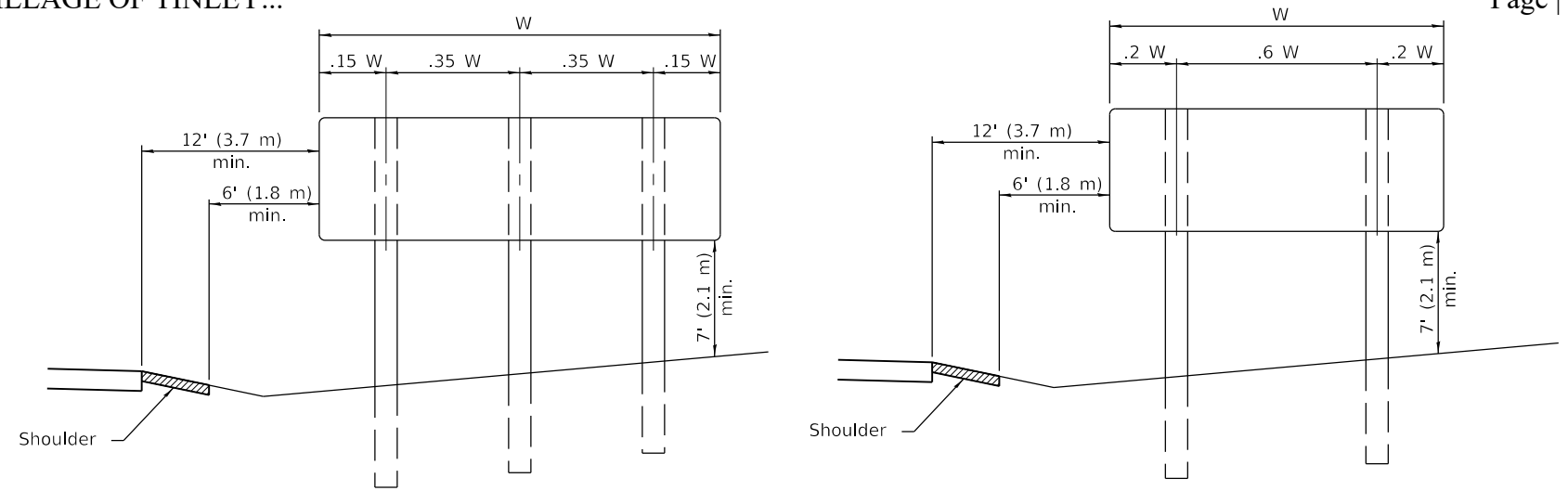

POST SPACING FOR NON-FREEWAY SIGN PANELS

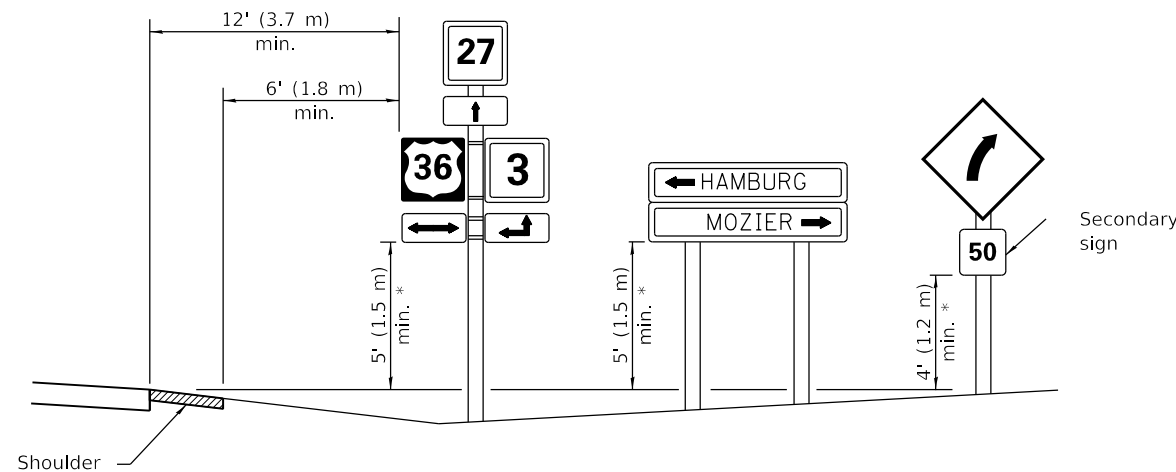

* In any area where parking is likely to occur or where there are obstructions to view or where signs are located over sidewalks, the height shall be at least 7' (2.1 m).

TWO LANE RURAL HIGHWAYS

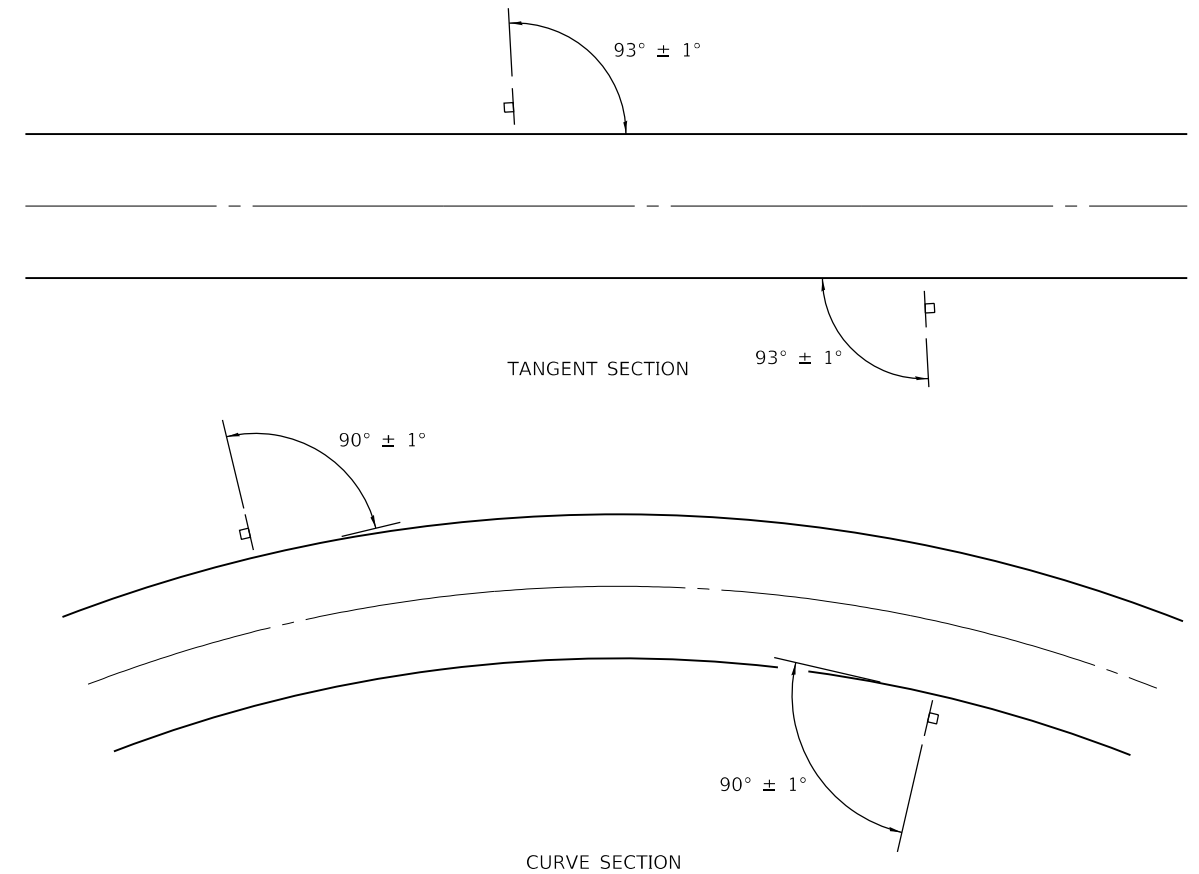

GROUND MOUNT SIGN POSITIONING

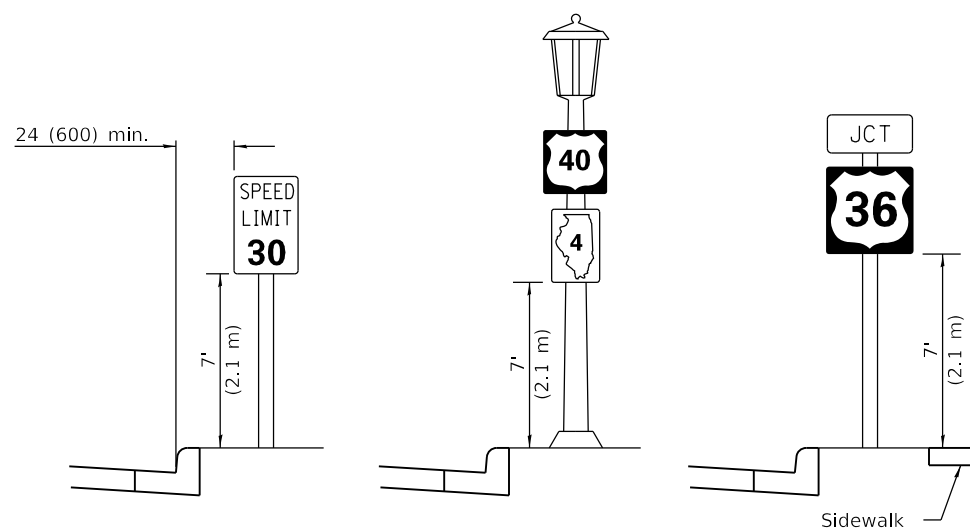

URBAN LOCATIONS

TYPICAL INSTALLATIONS

Signs in any area shall be erected to a uniform height above the edge of the pavement.

All dimensions are in inches (millimeters) unless otherwise shown.

Illinois Department of Transportation

PASSED January 1, 2014
Justin Mann
 ENGINEER OF OPERATIONS

APPROVED January 1, 2014
[Signature]
 ENGINEER OF DESIGN AND ENVIRONMENT

ISSUED 1-1-97

DATE	REVISIONS
1-1-14	Added shoulders and slopes.
	Changed sign distances from roadway and shoulder.
1-1-12	Rev. sign elev. for multilane hwy's. Revised sign elev. and dist. to curb for rural loc.

SIGN PANEL ERECTION DETAILS

STANDARD 720006-04

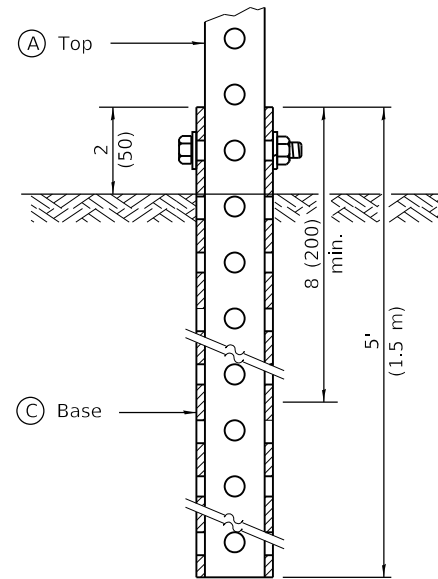

GROUND MOUNT DETAIL

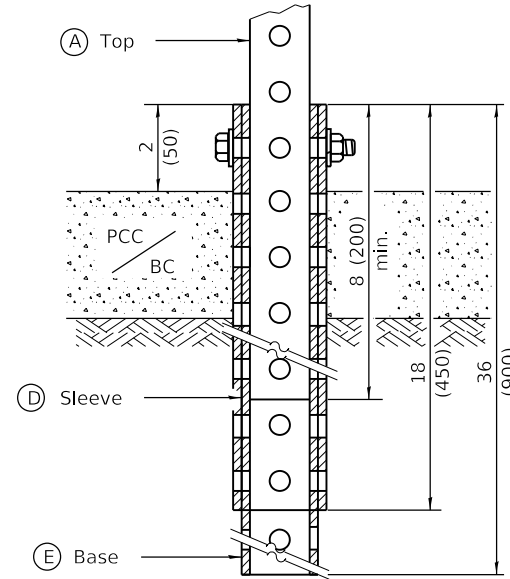

PAVEMENT MOUNT DETAIL

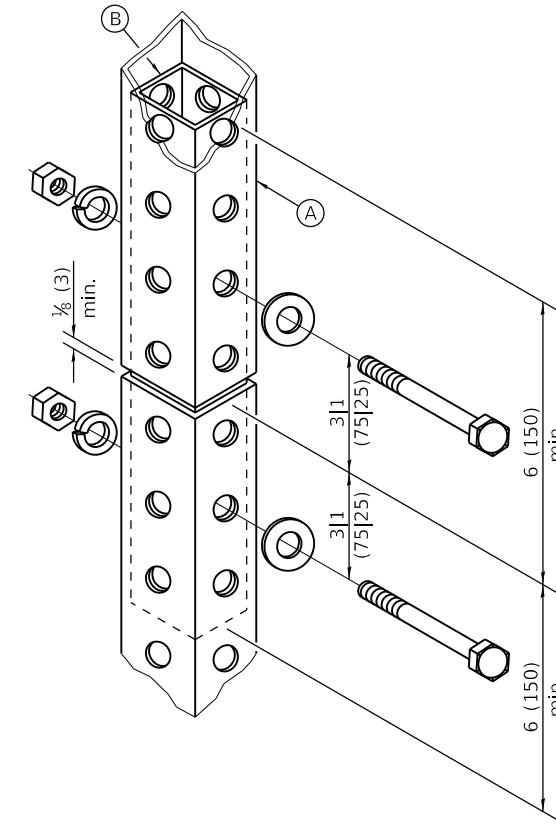

SPLICE DETAIL

(A)	2 x 2 x var. (51 x 51 var.)
(B)	1 3/4 x 1 3/4 x 12 (44 x 44 x 300)
(C)	2 1/4 x 2 1/4 x 60 (57 x 57 x 1500)
(D)	2 1/2 x 2 1/2 x 18 (64 x 64 x 450)
(E)	2 1/4 x 2 1/4 x 36 (57 x 57 x 900)

GENERAL NOTES

All bolts 3/8" (M10) hex head zinc or cadmium plated.

All dimensions are in inches (millimeters) unless otherwise shown.

DATE	REVISIONS
1-1-09	Switched units to English (metric).
1-1-07	New Standard. Used to be part of Standard 720006.

TELESCOPING STEEL SIGN SUPPORT

STANDARD 728001-01

Illinois Department of Transportation

PASSED January 1, 2009

ENGINEER OF OPERATIONS

APPROVED January 1, 2009

ENGINEER OF DESIGN AND ENVIRONMENT

ISSUED 1-1-07

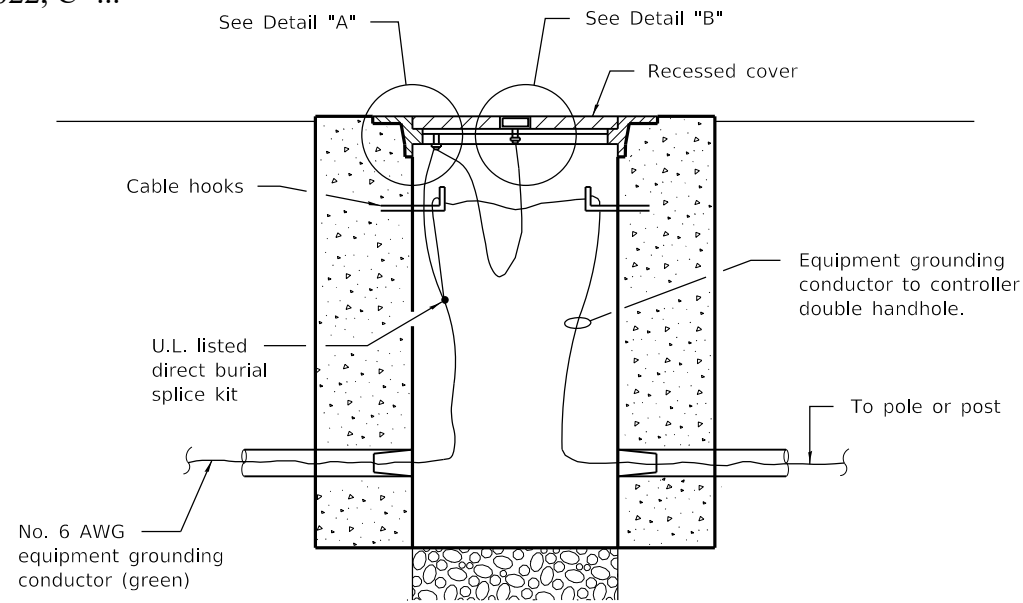

BONDING A HANDHOLE COVER & FRAME

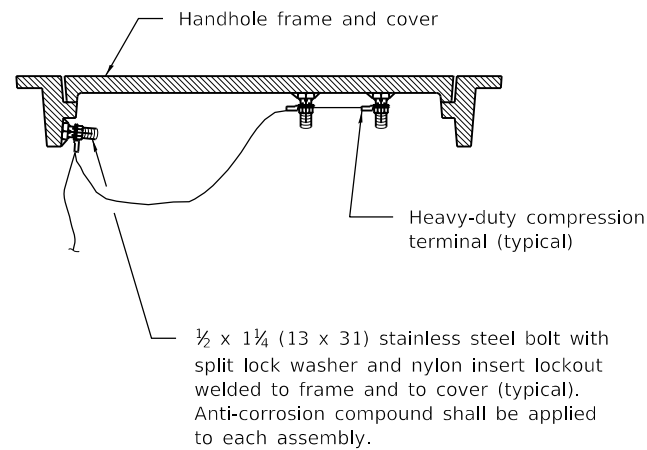

BONDING AN EXISTING HANDHOLE COVER & FRAME

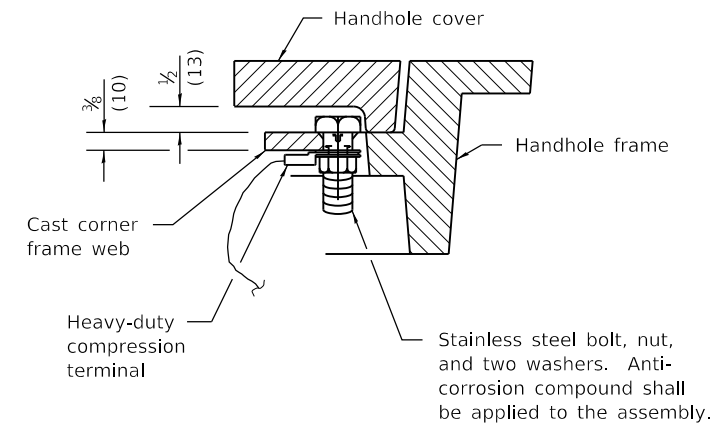

DETAIL "A"

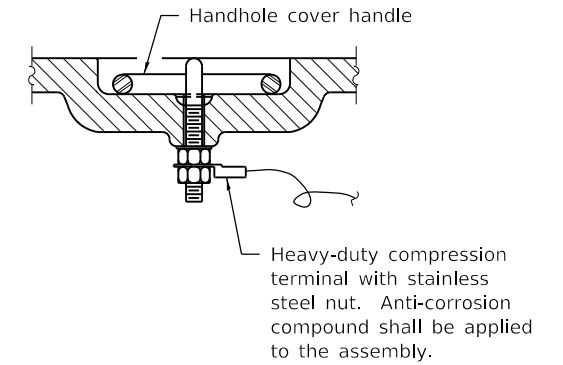

DETAIL "B"

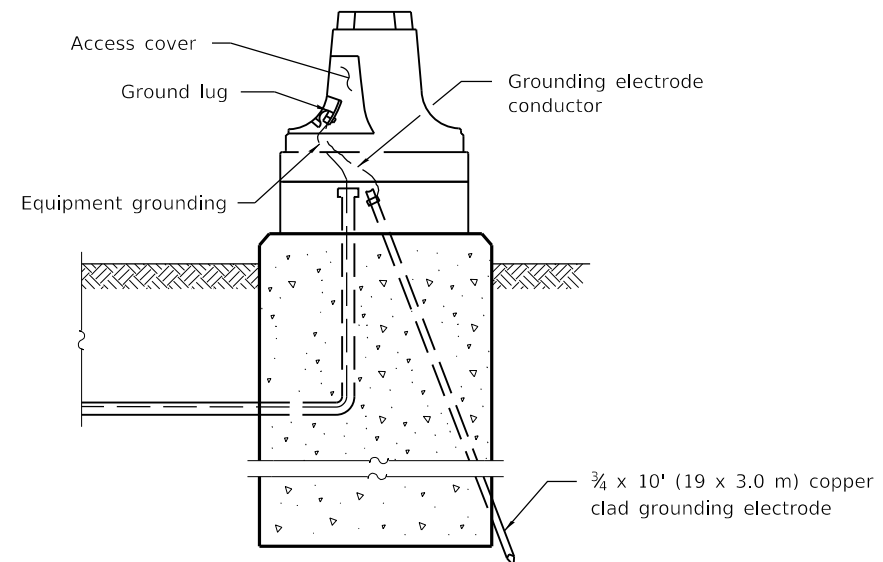

GROUNDING A MAST ARM POLE/POST



HEAVY-DUTY COMPRESSION TERMINAL

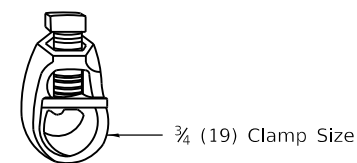

HEAVY-DUTY GROUND ROD CLAMP

All dimensions are in inches (millimeters) unless otherwise shown.

DATE	REVISIONS
1-1-09	Switched units to English (metric).
1-1-07	Revised terminology.

**TRAFFIC SIGNAL
GROUNDING & BONDING**

STANDARD 873001-02

Illinois Department of Transportation

PASSED January 1, 2009
[Signature]
 ENGINEER OF OPERATIONS

APPROVED January 1, 2009
[Signature]
 ENGINEER OF DESIGN AND ENVIRONMENT

ISSUED 4-1-06

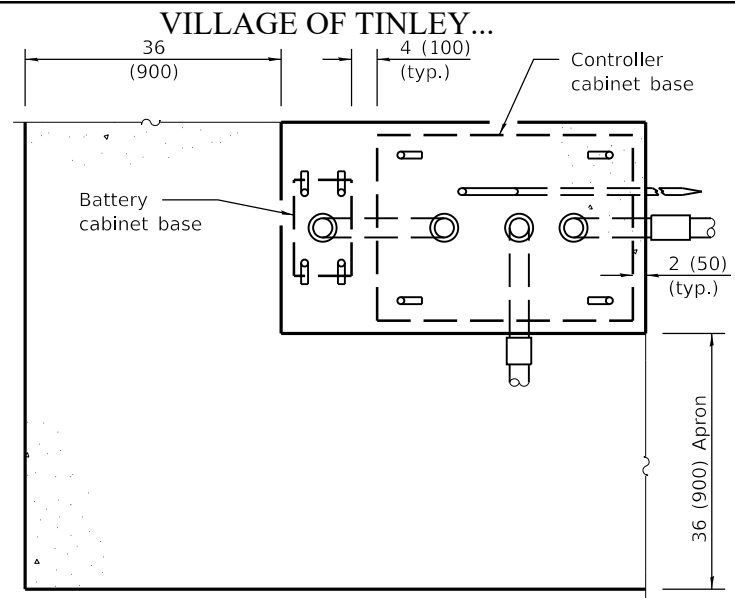

TOP VIEW

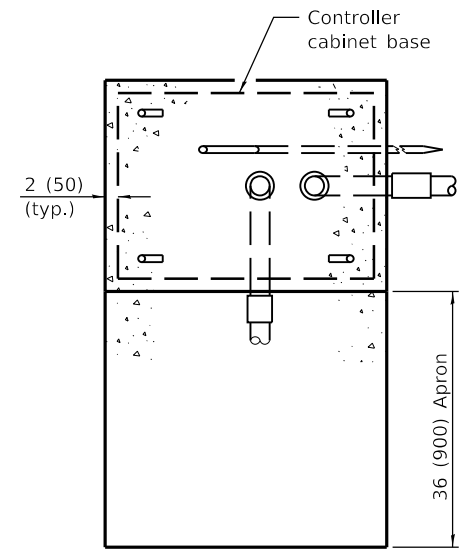

TOP VIEW

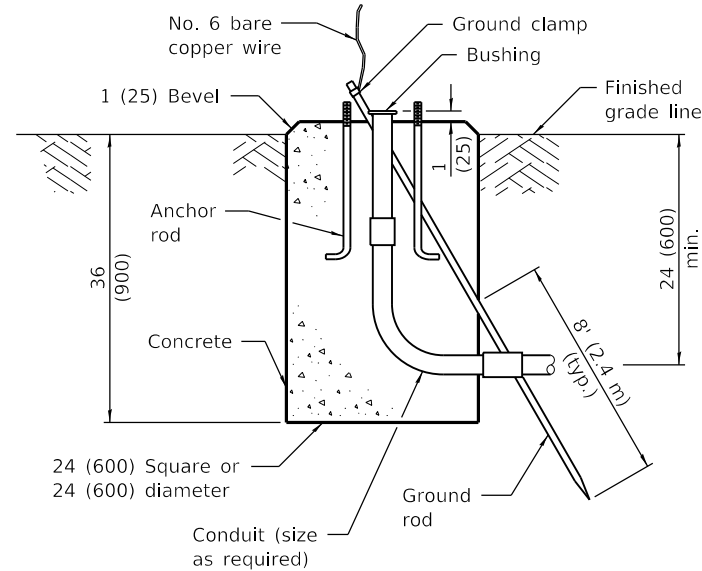

TYPE A

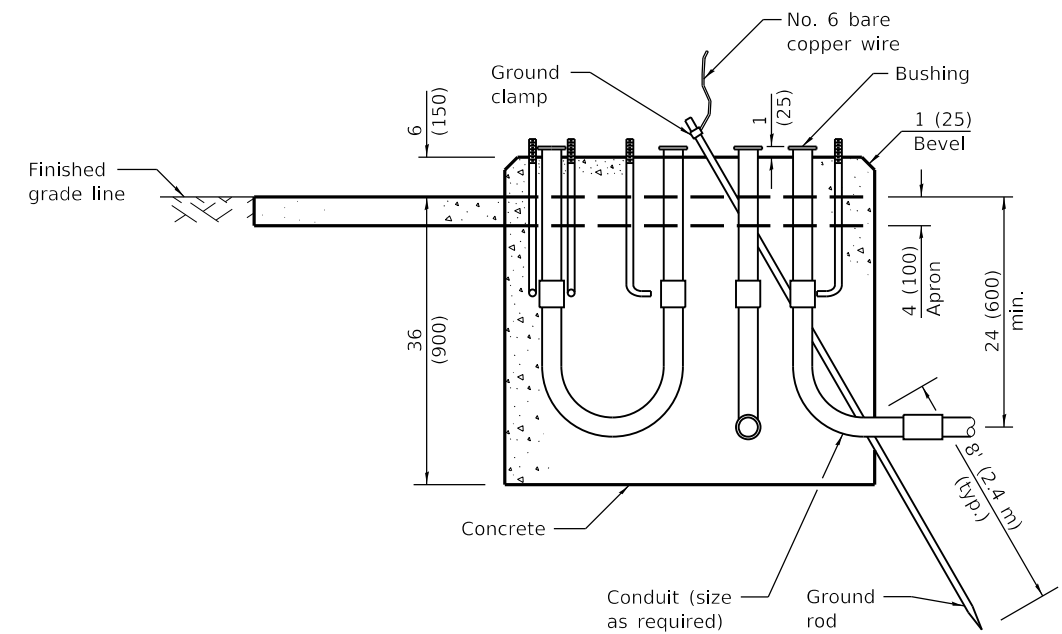

**TYPE C
FOR GROUND MOUNTED
CONTROLLER CABINET
AND UPS BATTERY CABINET**

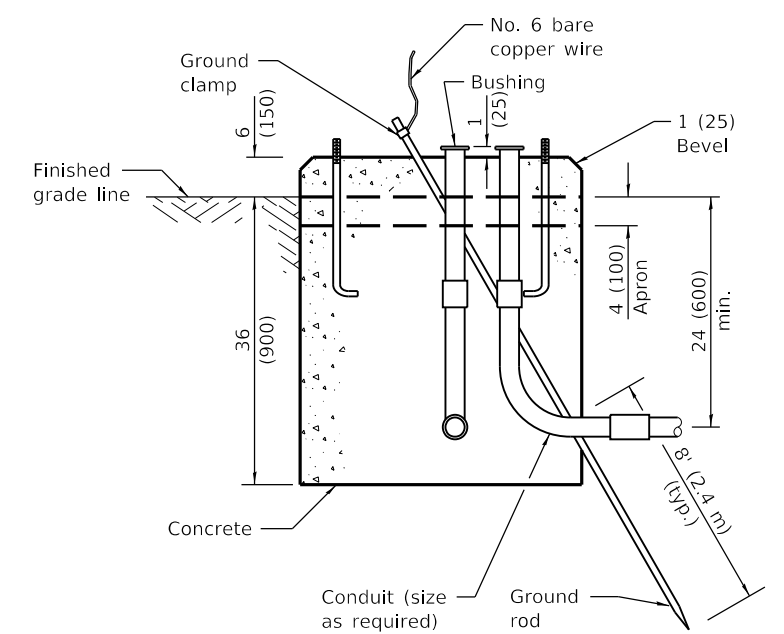

**TYPE D
FOR GROUND MOUNTED
CONTROLLER CABINET**

All dimensions are in inches (millimeters) unless otherwise shown.

Illinois Department of Transportation

PASSED January 1, 2021
Amy Ellis
 ENGINEER OF OPERATIONS

APPROVED January 1, 2021
S. E. EG
 ENGINEER OF DESIGN AND ENVIRONMENT

ISSUED 1-1-02

DATE	REVISIONS
1-1-21	Revised anchor rod end in Type E detail.
1-1-15	Revised TYPE E detail.

**CONCRETE
FOUNDATION DETAILS**

(Sheet 1 of 2)

STANDARD 878001-11

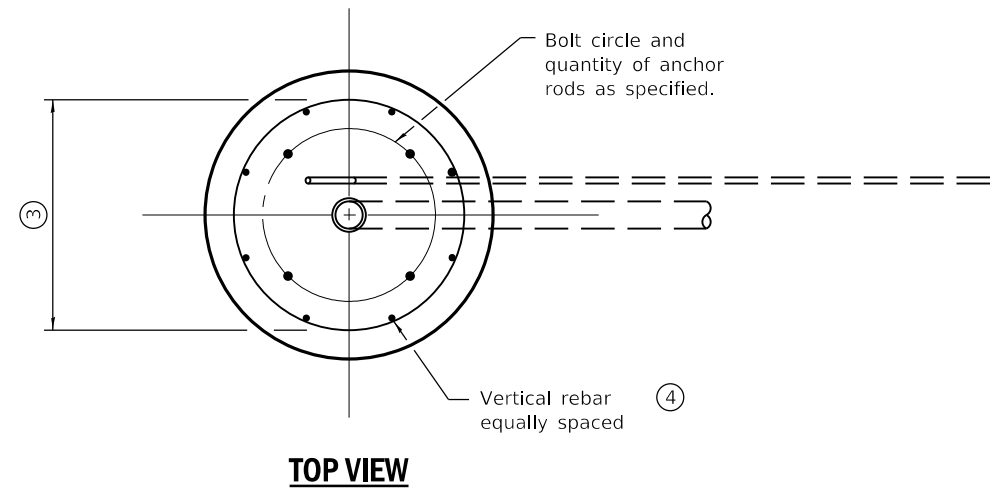

Mast Arm Length	① Foundation Depth *	② Foundation Diameter	③ Spiral Diameter	④ Quantity of Rebars	Size of Rebars
Less than 30' (9.1 m)	10'-0" (3.0 m)	30 (750)	24 (600)	8	6 (19)
Greater than or equal to 30' (9.1 m) and less than 40' (12.2 m)	13'-6" (4.1 m)	30 (750)	24 (600)	8	6 (19)
	11'-0" (3.4 m)	36 (900)	30 (750)	12	7 (22)
Greater than or equal to 40' (12.2 m) and less than 50' (15.2 m)	13'-0" (4.0 m)	36 (900)	30 (750)	12	7 (22)
Greater than or equal to 50' (15.2 m) and up to 55' (16.8 m)	15'-0" (4.6 m)	36 (900)	30 (750)	12	7 (22)
Greater than or equal to 56' (16.8 m) and less than 65' (19.8 m)	21'-0" (6.4 m)	42 (1060)	36 (900)	16	8 (25)
Greater than or equal to 65' (19.8 m) and up to 75' (22.9 m)	25'-0" (7.6 m)	42 (1060)	36 (900)	16	8 (25)

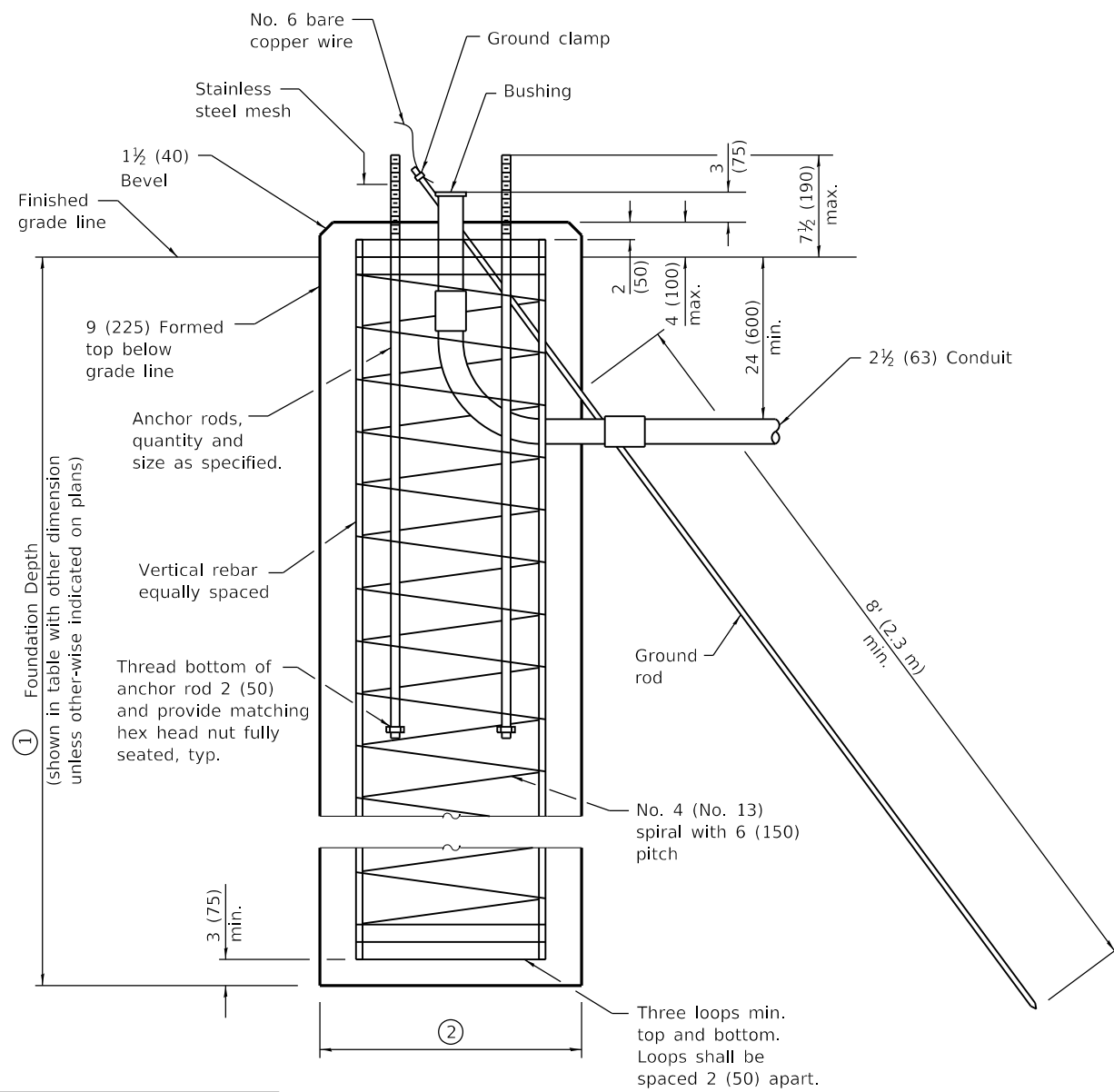

* For standard and combination mast arm assemblies. Foundation depths for standard dual mast arms with the longest arm length upto and including 55' (16.8 m) shall be increased by 1' (0.3 m) of that shown in the table, based on the longer of the two arms.

These foundation depths are for sites which have cohesive soils (clayey silt, sandy clay, etc.) along the length of the shaft, with an average Unconfined Compressive Strength (Qu) > 1.0 tsf (100 kpa). This strength shall be verified by boring data prior to construction or with testing by the Engineer during foundation drilling. The Bureau of Bridges & Structures should be contacted for a revised design if other conditions are encountered.

TYPE E

Illinois Department of Transportation

PASSED January 1, 2021
Amy Ellis
 ENGINEER OF OPERATIONS

APPROVED January 1, 2021
S. E. EG
 ENGINEER OF DESIGN AND ENVIRONMENT

ISSUED 1-1-02

**CONCRETE
 FOUNDATION DETAILS**

(Sheet 2 of 2)

STANDARD 878001-11

TABLE OF CONTENTS

DESCRIPTION OF PROJECT 2

CCDOETH PERMIT 2

TRAFFIC SIGNAL WORK GENERAL 3

TRAFFIC SIGNAL POST 16

CONCRETE FOUNDATION..... 18

FLASHING BEACON INSTALLATION, SOLAR POWERED 19

REMOVE EXISTING SIGN POST 20

TRAFFIC CONTROL AND PROTECTION, COMPLETE..... 21

COOK COUNTY

SPECIAL PROVISIONS

The following Special Provisions supplement the "Standard Specifications for Road and Bridge Construction," adopted January 1, 2022, the latest edition of the "Manual on Uniform Traffic Control Devices for Streets and Highways," and the Supplemental Specifications (if applicable) which apply to and govern the flashing beacon installation for the project area along 80th Ave (County Hwy W32) at 167th Street; and in case of conflict with any part or parts of said Specifications, the said Special Provisions shall take precedence and shall govern.

DESCRIPTION OF PROJECT

The work consists of signage changes and installing solar powered flashing beacon sign assemblies for the school zone located along 80th Ave (County Hwy W32) near 167th Street.

CCDOTH PERMIT

The work involves County right-of-way and a permit is required to construct this project. The contractor will be required to acquire a \$20,000 bond and submit associated permit and insurance documentation. The costs associated with acquiring the bond and submitting associated documents shall be included in the contract cost.

**SPECIAL PROVISION
FOR
TRAFFIC SIGNAL WORK GENERAL**

Effective: 01/01/18

Revised: 5/1/21 (Revised Phone Number)

All work and equipment performed and installed under this contract, shall be governed and shall comply to the State of Illinois "Standard Specifications for Road and Bridge Construction" latest edition, herein referred to as the Standard Specifications and the "District One Standard Design Details"; the State of Illinois "Manual on Uniform Traffic Control Devices for Streets and Highways", latest edition; the "National Electrical Code" latest edition herein referred to as the NEC; the National Electrical Manufacturers Association, herein referred to as NEMA (all publications for traffic control items) latest editions; the International Municipal Signal Association, herein referred to as IMSA "Official Wire & Cable Specifications Manual" latest edition; the Institute of Transportation Engineers, herein referred to as the ITE, Technical Report No.1, "A Standard for Adjustable Face Vehicular Traffic Control Heads"; AASHTO "Standard Specifications for Structural Supports for Highway Signs, Luminaries and Traffic Signals" and the "Supplemental Specifications" and "Recurring Special Provisions" noted herein.

The following Special Provisions supplement the above specifications, manuals, and code. The intent of these Special Provisions is to prescribe the materials and construction methods commonly used for traffic signal installations. All material furnished shall be new unless otherwise noted herein. The locations and the details of all installations shall be as indicated on the Plans or as directed by the Engineer. Traffic signal construction and maintenance work shall be performed by personnel holding IMSA Traffic Signal Technician Level II certification. The work to be done under this contract consists of furnishing and installing all traffic signal work as specified in the Plans and as specified herein in a manner acceptable and approved by the Engineer. In case of conflict with any part or parts of said documents, these Special Provisions shall take precedence and shall govern.

In order to reduce possible vehicular conflicts with fixed objects and avoid public criticism, it is necessary to require that no posts, poles, heads, or controller cabinets be installed until all traffic signal control equipment is brought to and located on the job site.

The construction, installation and/or removal work shall be accomplished at all the intersections within the limits of this project or as shown in the plans.

Description of Work. The work to be done under this contract consists of furnishing and installing all traffic signal work as specified on the Plans and as specified herein in a manner acceptable and approved by the Engineer.

Control of Traffic Signal Materials.

All work shall meet the requirements of the "Standard Specifications for Road and Bridge Construction", except as follows:

The controller and all control equipment shall be of a manufacturer that is approved by this Department. All equipment shall have a representative and shop located in the six (6) county Chicago areas. All equipment installed in the controller cabinet shall be from a single supplier. The supplier shall be responsible for service and support for this equipment.

The intent of this Section is to prescribe the materials and construction methods commonly used for traffic signal installations. All material furnished shall be new unless otherwise noted herein. Traffic materials and equipment shall bear the U.L. label whenever such labeling is available.

All iron and steel products, which are to be incorporated into work shall be domestically manufactured or produced and fabricated. The contractor shall obtain from the iron or steel producer and/or fabricator, in addition to the mill analysis, a certification that all iron or steel materials meet these domestic source requirements.

The application of all coatings, epoxy, galvanizing, painting, etc., to metal products shall be domestically applied.

Metal material other than iron and steel, which are not domestically produced, may be accepted provided:

- (a) The contractor notifies the Department in advance of his/her intention to use other than domestically manufactured or produced material.
- (b) Written evidence is provided in English of compliance with all requirements of the specifications.
- (c) Physical tests conducted by the department verify the acceptability of the material.

Before any signal equipment, including mast arm assemblies, poles, controller cabinets, all control equipment and signal heads, are delivered to the job site, the Contractor shall obtain and forward to the Engineer a certified, notarized statement from the manufacturer, containing the catalog numbers of the equipment and/or material, guaranteeing that the equipment and/or material, after manufacture, comply in all respects with the requirements of the Specifications and these Special Provisions.

All material approval requests shall be within thirty (30) consecutive calendar days after the Contract is awarded, or at the pre-construction meeting, whichever is first. A list of major traffic signal items can be found in Article 801.05. Material or equipment which is similar or identical shall be the product of the same manufacturer, unless necessary for system continuity. Traffic signal materials and equipment shall bear the U.L. label whenever such labeling is available.

All cost of work and materials required to comply with the above requirements shall be included in the pay item bid prices, under which the subject materials and signal equipment are paid, and no additional compensation will be allowed. Materials and signal equipment not complying with the above requirements that have been installed on the job will be done at the Contractor's own risk and may be subject to removal and disposal at the Contractor's expense.

The Contractor must submit the following for approval by the Engineer:

- Four (4) complete set of manufacturer's descriptive literature, drawings, and specifications of the traffic signal equipment, handholes, junction box, cable, conduit and all associated items that will be installed on the contract. If the literature contains more than one item, the Contractor shall indicate which item or items will be furnished.
- Partial or incomplete submittal will be returned without review.
- The contractor shall supply samples of all wire and cable, and shall make up and supply samples of each type of cable splice proposed for use in the work for the-Engineer's approval.
- Seven (7) complete shop drawings of the mast arm assemblies and poles including combination mast arm poles are required, showing in detail the fabrication, anchor bolts, reinforcing materials, design material, thickness of sections and weld sizes. These drawing shall be approved by IDOT at least 11" x 17" (275mm x 425mm) in size and adequate quality for microfilming.
- Certain non-standard mast arm poles and assemblies will require additional review. The Contractor shall account for additional review time in their schedule.
- Seven (7) copies of a letter from the Traffic Signal Contractor on company letterhead listing contract number or permit number, project location limits, pay item number and description and listing the manufacturer's name and model numbers of the proposed equipment to be supplied and stating that the proposed equipment meets all Contract requirements. The letter will be reviewed by the Engineer to determine whether the equipment to be used is approvable. The letters will be stamped as approved or not approved accordingly and returned to the Contractor.
- Five (5) copies of a letter from the Traffic Signal Contractor listing the System Coordination and Timing (SCAT) consultant's name shall be supplied. The letter will be reviewed by the Engineer to determine whether the SCAT consultant to be used is approved. The letters will be stamped as approved or not approved accordingly and returned to the Contractor.
- Where certifications and/or warranties are specified. The information submitted for approval shall include certifications and warranties. Certifications involving inspections and/or tests of material shall be complete with all test data, dates and times.
- All above shall be stamped with the Section Number, Permit Number, or Contract Number and Intersection(s) name(s). Pay item numbers shall also be included. If the above required information is not on each sheet of the above literature or letters, the equipment and material cuts will not be reviewed and shall be returned to the Contractor.
- All submitted items reviewed and marked 'APPROVED AS SUBMITTED', 'APPROVED AS NOTED', 'DISAPPROVED', 'INCOMPLETE' or ' NOT REVIEW' are to be resubmitted in their entirety, unless otherwise

indicated within the submittal comments, with a disposition of previous comments to verify contract compliance at no additional cost to the contract.

- Exceptions, Deviations and Substitutions. In general, exceptions to and deviations from the requirements of the Contract Documents will not be allowed. It is the Contractor's responsibility to note any deviations from Contract requirements at the time of submittal and to make any requests for deviations in writing to the Engineer. In general, substitutions will not be acceptable. Requests for substitutions must demonstrate that the proposed substitution is superior to the material or equipment required by the Contract Documents. No exceptions, deviations or substitutions will be permitted without the approval of the Engineer.
- After the engineer reviews the submittals for conformance with the design concept of the project, the Engineer will stamp the drawings indicating their status. The Engineer's review is for conformance with design concept only. It is the Contractor's responsibility to coordinate the various items into a working system as specified. The Contractor shall not be relieved from responsibility for errors or omissions in the shop working, layout drawings, or other documents by the Departments approval thereof. The Contractor must be in full compliance with contract and specification requirements.
- Contractor shall not order major equipment such as mast arm assemblies prior to Engineer approval of the Contractor marked proposed traffic signal equipment locations to assure proper placement of contract required traffic signal displays, push buttons and other facilities. Field adjustments may require changes in proposed mast arm length and other coordination.

Marking Proposed Locations.

Revise the following to Article 801.09 of the Standard Specifications:

Revise "Marking Proposed Locations for Highway Lighting System" to read "Marking Proposed Locations for Highway Lighting System and Traffic Signals."

It shall be the contractor's responsibility to verify all dimensions and conditions existing in the field prior to ordering materials and beginning construction. This shall include locating the mast arm foundations and verifying the mast arms lengths.

Maintenance and Responsibility.

Revise Article 801.11 to read as follows.

- a) Existing traffic signal installations and/or any electrical facilities at all or various locations may be altered or reconstructed totally or partially as part of the work on this Contract. The Contractor is hereby advised that all traffic control equipment, presently installed at these locations, may be the property of the State of Illinois, Department of Transportation, Division of Highways, Cook County Highway Department, Private Developer, or the Municipality in which they are located. Once the Contractor has begun any work on any portion of the project all traffic signals within the limits of this contract or those which have the item "Maintenance of Existing Traffic Signal Installation", "Temporary Traffic Signal Installation(s)" and/or "Maintenance of Existing Flashing Beacon

Installation”, shall become the full responsibility of the Contractor. Automatic Traffic Enforcement equipment is not owned by the County and the Contractor shall not be responsible for maintaining it during construction. The Contractor shall supply the engineer and the Department’s Electrical Maintenance Contractor a 24-hour emergency contact name and telephone number.

- b) When the project has a pay item for "Maintenance of Existing Traffic Signal Installation", "Temporary Traffic Signal Installation(s)" and/or "Maintenance of Existing Flashing Beacon Installation", the Contractor must notify both the Design Engineer at (312) 603-1734 and the Department’s Electrical Maintenance Contractor, of their intent to begin any physical construction work on the Contract or any portion thereof. This notification must be made a minimum of seven (7) working days prior to the start of construction to allow sufficient time for inspection of the existing traffic signal installation(s) and transfer of maintenance to the Contractor. If work is started prior to an inspection, maintenance of the traffic signal installation(s) will be transferred to the Contractor without an inspection. The Contractor will become responsible for repairing or replacing all equipment that is not operating properly or is damaged at no cost to the owner of the traffic signal. Final repairs or replacement of damaged equipment must meet the approval of the Engineer prior to or at the time of final inspection otherwise the traffic signal installation will not be accepted.
- c) Regional transit, County and other agencies may also have equipment connected to existing traffic signal or peripheral equipment such as PTZ cameras, switches, transit signal priority (TSP and BRT) servers and other devices that shall be included with traffic signal maintenance at no additional cost to the contract.
- d) Contracts such as pavement grinding or patching which result in the destruction of traffic signal loops will require a maintenance transfer. The Contractor is required to notify of intent to work and an inspection. A minimum of seven (7) working days prior to the loop removal, the Contractor shall notify the Design Engineer at (312) 603-1734, the Department’s Electrical Maintenance Contractor and the owner of automatic traffic enforcement prior to the loop removal, at which time arrangements will be made to adjust the traffic controller timing to compensate for the absence of detection. Damaged Automatic Traffic Enforcement equipment, including cameras, detectors, or other peripheral equipment, shall be replaced by others, per Permit agreements or other agreements, at no cost to the contract except for City of Chicago projects in which the detectors shall be replaced. See additional requirements in these specifications under Inductive Loop Detector.
- e) The Contractor is further advised that the existing traffic signal(s), and/or the existing temporary installation(s), must remain in operation during all construction stages except for the most essential down time. Any shutdown of the traffic signal installation(s), for a period to exceed fifteen (15) minutes, must have the prior approval of the Engineer. Such approval will generally only be granted during the period extending from 10:00 a.m. to 3:00 p.m. on weekdays. Shutdowns will not be allowed during inclement weather or during Holiday periods. Any other traffic signal shutdown, either for periods in excess of one (1) hour or outside of the 10:00 a.m. to 3:00 p.m. weekday period must have prior approval of the Engineer. The Contractor, prior to the commencement of his work, shall

notify the State Electrical Maintenance Contractor, the Cook County Electrical Maintenance Contractor, or the concerned Municipality, of his intent to perform this work.

- f) The Contractor shall be fully responsible for the safe and efficient operation of the traffic signals. Any inquiry, complaint or request by the Department, the Department's Electrical Maintenance Contractor or the public, shall be investigated and repairs begun within one hour. Failure to provide this service will result in liquidated damages of \$1000 per day per occurrence. In addition, the Department reserves the right to assign any work not completed within this timeframe to the Electrical Maintenance Contractor. All costs associated to repair this uncompleted work shall be the responsibility of the Contractor. Failure to pay these costs to the Electrical Maintenance Contractor within one month after the incident will result in additional liquidated damages of \$1000 per month per occurrence. Unpaid bills will be deducted from the cost of the Contract. The Department's Electrical Maintenance Contractor may inspect any signaling device on the Department's highway system at any time without notification.
- g) Any proposed activity in the vicinity of a highway-rail grade crossing must adhere to the guidelines set forth in the current edition of the Manual on Uniform Traffic Control Devices (MUTCD) regarding work in temporary traffic control zones in the vicinity of highway-rail grade crossings which states that lane restrictions, flagging, or other operations shall not create conditions where vehicles can be queued across the railroad tracks. If the queuing of vehicles across the tracks cannot be avoided, a uniformed law enforcement officer or flagger shall be provided at the crossing to prevent vehicles from stopping on the tracks, even if automatic warning devices are in place.
- h) The Contractor shall be responsible to clear snow, ice, dirt, debris or other condition that obstructs visibility of any traffic signal display.
- i) The Contractor shall maintain the traffic signal in normal operation during short or long-term loss of utility or battery back-up power at critical locations designated by the Engineer. Critical locations may include traffic signals interconnected to railroad warning devices, expressway ramps, intersection with an SRA route, critical corridors or other locations identified by the Engineer. Temporary power to the traffic signal must meet applicable NEC and OSHA guidelines and may include portable generators and/or replacement batteries.

Damage to Traffic Signal System.

Add the following to Article 801.12(b).

- a) Any damaged equipment or equipment not operating properly from any cause whatsoever shall be replaced with new equipment provided by the contractor at no additional cost to the Contract and/or owner of the traffic signal system all as approved by the Engineer. Final repairs or replacement of damaged equipment must meet the approval of the Engineer prior to or at the time of final inspection

otherwise the traffic signal will not be accepted. Cable splices outside the controller cabinet will not be allowed.

- b) Temporary replacement of damaged or knockdown of a mast arm pole assembly shall require construction of a full or partial span wire signal installation or other method approved by the Engineer to assure signal heads are located overhead and over traveled pavement. Temporary replacement of mast arm mount signals with post mount signals will not be permitted.
- c) Automatic Traffic Enforcement equipment, such as Red-Light Enforcement cameras, detectors, and peripheral equipment, damaged or not operating properly from any cause whatsoever, shall be the responsibility of the municipality or the Automatic Traffic Enforcement Company per Permit agreement or other agreements.

Traffic Signal Inspection (Turn – On).

Revise Article 801.15b to read as follows.

- a) The Contractor must have all electric work completed, the electrical service installation connected by the utility company and equipment field tested by the Vendor prior to the Department's "turn-on" field inspection. If in the event the Engineer determines the work is not complete and the inspection will require more than two (2) hours to complete, the inspection shall be canceled and the Contractor will be required to reschedule at another date. The maintenance of the traffic signals will not be accepted until all punch list work is corrected and re-inspected. The Department will not grant a field inspection until written certification is provided from the Contractor stating the equipment has been field tested and the intersection is operating according to Contract requirements.
- b) When the road is open to traffic, except as otherwise provided in Section 850 of the Standard Specification, the Contractor may request a turn-on and inspection of the completed traffic signal installation at each separate location. This request must be made to the Design Engineer at (312) 603-1734 a minimum of seven (7) working days prior to the time of the requested inspection. The Department will not grant a field inspection until notification is provided from the Contractor that the equipment has been field tested and the intersection is operating according to Contract requirements. The Contractor must invite local fire department personnel to the turn-on when Emergency Vehicle Pre-emption (EVP) is included in the project. When the contract includes the item RE-OPTIMIZE TRAFFIC SIGNAL SYSTEM, OPTIMIZE TRAFFIC SIGNAL SYSTEM, or TEMPORARY TRAFFIC SIGNAL TIMINGS, the Contractor must notify the SCAT Consultant of the turn-on schedule, as well as stage changes and phase changes during construction.
- c) The Contractor must have all traffic signal work completed and the electrical service installation connected by the utility company prior to requesting an inspection and turn-on of the traffic signal installation. The Contractor shall be responsible to provide a Police Officer to direct traffic at the time of testing.

- d) The Contractor shall provide a representative from the control Equipment Vendor's office to attend the traffic signal inspection for both permanent and temporary traffic signal turn-ons. Upon demonstration that the signals are operating and all work is completed in accordance with the Contract and to the satisfaction of the Engineer, the Engineer will then allow the signals to be placed in continuous operation. The Agency that is responsible for the maintenance of each traffic signal installation will assume the maintenance upon successful completion of this inspection.
- e) Acceptance of the traffic signal equipment by the Department shall be based upon inspection results at the traffic signal turn-on, completeness of the required documentation and successful operation during a minimum 72 hour "burn-in" period following activation of the traffic signal. If approved, traffic signal acceptance shall be verbal at the turn-on inspection followed by written correspondence from the Engineer. The Contractor shall be responsible for all traffic signal equipment and associated maintenance thereof until Departmental acceptance is granted.
- f) All equipment and/or parts to keep the traffic signal installation operating shall be furnished by the Contractor. No spare traffic signal equipment is available from the Department.
- g) All punch list work shall be completed within two (2) weeks after the final inspection. The Contractor shall notify the Design Engineer at (312) 603-1734 to inspect all punch list work. Failure to meet these time constraints shall result in liquidated damage charges of \$500 per month per incident.
- h) All cost of work and materials required to comply with the above requirements shall be included in the pay item bid prices under which the subject materials and signal equipment are paid and no additional compensation will be allowed. Materials and signal equipment not complying with the above requirements that have been installed on the job will be at the Contractor's own risk and shall be subject to removal and disposal at the Contractor's expense.
- i) The Contractor shall furnish the Cook County Highway Department with any special tools or wrenches that may be required for assembling or maintaining the control equipment and traffic control signal head assemblies.
- j) All control cable, when complete in place but before permanent connection, shall be subject to insulation tests at the discretion of the Engineer. The tests shall be made with approved insulation resistance testing equipment rated at 500 volts D.C. and witnessed by the Engineer. Results of these tests shall be submitted to the Department in written form, bearing the Engineer's signature and shall become part of the project records. A final inspection of the traffic signal installation shall not be held until results of this insulation test have been received.
- k) All equipment such as new controllers and allied central equipment with the exception of cable, conduit, and other materials which require the use of the State of Illinois Materials Testing Laboratories, shall be built in the supplier's shop and inspected by a representative of this Department prior to the installation of such equipment, and upon approval of this equipment an inspection ticket will be issued to the Contractor by the inspection agency (State of Illinois Material Testing Laboratory or the Cook County Highway Mechanical-Electrical Section). The controller and allied control

equipment shall be prepared in the suppliers shop and run under a load of a minimum of 500 watts per phase for at least 48 hours before it is inspected for proper operation and sequencing. After it passes this test an inspection ticket will be issued by the Cook County Highway Mechanical-Electrical Section representative and it can then be delivered to the job site for installation.

- l) Upon completion of the installation, a final inspection will be carried out by qualified representatives of the Highway Agencies involved.
- m) If the Contractor fails to comply with any of the requirements, the County shall impose such sanction as it may determine to be appropriate including but not limited to withholding all payments to the Contractor on this contract until the provisions of this special provision are complete with and/or implementation of article 108.10 of the standard specifications.

At the final inspection it will be required that the Contractor will have submitted to the Engineer all necessary inspection tickets for all new equipment and materials installed under this Contract. If the Contractor has not obtained the inspection tickets on any portion of the new equipment and materials, the representative of this Department will have the authority to postpone the final inspection until the above has been satisfied. Any postponement of the final inspection for this reason shall not relieve the Contractor of his full maintenance responsibilities until such time as the installation is re-inspected and accepted by the County.

The County requires the following Final Project Documentation from the Contractor at traffic signal turn-ons in electronic format in addition to hard copies where noted. A CD/DVD shall be submitted with separate folders corresponding to each numbered title below. The CD/DVD shall be labelled with date, project location, company and contract or permit number. Record Drawings, Inventory and Material Approvals shall be submitted prior to traffic signal turn-on for review by the Department as described here-in.

The County requires the following from the Contractor at traffic signal turn-on.

- 1) The Contractor shall, at the turn-on furnish one hard copy set of signal plans (24"x36") of record with field revisions marked in red ink to the maintaining agency.
- 2) Field Testing. Written notification from the Contractor and the equipment vendor of satisfactory field testing with corresponding material performance measurements, such as for detector loops and fiber optic systems (see Article 801.13). One hard copy of all contract required performance measurement testing shall also be provided.
- 3) A knowledgeable representative of the controller equipment supplier shall be required at the permanent and temporary traffic signal turn-on. The representative shall be knowledgeable of both cabinet design and controller functions and shall have sufficient test and spare equipment to make the traffic signal installation operational.
- 4) Pictures. Digital pictures of a minimum 12M pixels of each intersection approach showing all traffic signal displays and equipment. Pictures shall include controller cabinet equipment in enough detail to clearly identify manufacture and model of major equipment.

- 5) Materials Approval. The material approval letter. A hard copy shall also be provided.
- 6) Manuals. Operation and service manuals of the signal controller and associated control equipment. One hard copy shall also be provided.
- 7) Cabinet Wiring Diagram and Cable Logs. Five (5) hard copies 11" x 17" of the cabinet wiring diagrams shall be provided along with electronic pdf and dgn files of the cabinet wiring diagram. Five hard copies of the cable logs and electronic excel files shall be provided with cable #, number of conductors and spares, connected device/signal head and intersection location.
- 8) Controller Programming Settings. The traffic signal controller's timings; backup timings; coordination splits, offsets, and cycles; TBC Time of Day, Week and Year Programs; Traffic Responsive Program, Detector Phase Assignment, Type and Detector Switching; and any other functions programmable from the keyboard. The controller manufacturer shall also supply a printed form, not to exceed 11" x 17" for recording that data noted above. The form shall include a location, date, manufacturer's name, controller model and software version. The form shall be approved by the Engineer and a minimum of three (3) copies must be furnished at each turn-on. The manufacturer must provide all programming information used within the controller at the time of turn-on.
- 9) All Manufacturer and Contractor warranties and guaranties required by Article 801.14.
- 10) GPS coordinate of traffic signal equipment as describe in the Record Drawings section herein.

RECORD DRAWINGS

The requirements listed for Electrical Installation shall apply for Traffic Signal Installations in Article 801.16. Revise the 2nd paragraph of Article 801.16 of the Standard Specifications to read:

- a. When the work is complete, and seven days before the request for a final inspection, the full-size set of contract drawings. Stamped "RECORD DRAWINGS", shall be submitted to the Engineer for review and approval and shall be stamped with the date and the signature of the Contractor's supervising Engineer or electrician. The record drawings shall be submitted in PDF format on CDROM as well as hardcopy for review and approval. If the contract consists of multiple intersections, each intersection shall be saved as an individual PDF file with TS# and location name in its file name.
- b. In addition to the record drawings, copies of the final catalog cuts which have been Approved or Approved as Noted shall be submitted in PDF format along with the record drawings. The PDF files shall clearly indicate the pay item either by filename or PDF Table of Contents referencing the respective pay item number for multi-item PDF files. Specific part or model numbers of items which have been selected shall be clearly visible."

Add the following to Article 801.16 of the Standard Specifications:

"In addition to the specified record drawings, the Contactor shall record GPS coordinates of the following traffic signal components being installed, modified or being affected in other ways by this contract:

- All Mast Arm Poles and Posts
- Traffic Signal Wood Poles
- Rail Road Bungalow
- UPS
- Handholes
- Conduit roadway crossings
- Controller Cabinets
- Communication Cabinets
- Electric Service Disconnect locations
- CCTV Camera installations
- Fiber Optic Splice Locations
- Conduit Crossings

Datum to be used shall be North American 1983.

Data shall be provided electronically and in print form. The electronic format shall be compatible with MS Excel. Latitude and Longitude shall be in decimal degrees with a minimum of 6 decimal places. Each coordinate shall have the following information:

1. File shall be named: TSXXX-YY-MM-DD (i.e. TS22157_15-01-01)
2. Each intersection shall have its own file
3. Row 1 should have the location name (i.e. 103rd Street at Central Avenue)
4. Row 2 is blank
5. Row 3 is the headers for the columns
6. Row 4 starts the data
7. Column A (Date) – should be in the following format: MM/DD/YYYY
8. Column B (Item) – as shown in the table below
9. Column C (Description) – as shown in the table below
10. Column D and E (GPS Data) – should be in decimal form, per the County special provisions

Examples:

Date	Item	Description	Latitude	Longitude
01/01/2015	MP (Mast Arm Pole)	NEQ, NB, Dual, Combination Pole	41.580493	-87.793378
01/01/2015	HH (Handhole)	Heavy Duty, Fiber, Intersection, Double	41.558532	-87.792571
01/01/2015	ES (Electrical Service)	Ground mount, Pole mount	41.765532	-87.543571
01/01/2015	CC (Controller Cabinet)		41.602248	-87.794053
01/01/2015	RSC (Rigid Steel Crossing)	IL 31 east side crossing south leg to center HH at Klausen	41.611111	-87.790222
01/01/2015	PTZ (PTZ)	NEQ extension pole	41.593434	-87.769876
01/01/2015	POST (Post)		41.651848	-87.762053

01/01/2015	MCC (Master Controller Cabinet)		41.584593	-87.793378
01/01/2015	COMC (Communication Cabinet)		41.584600	-87.793432
01/01/2015	BBS (Battery Backup System)		41.558532	-87.792571

Prior to the collection of data, the contractor shall provide a sample data collection of at least six data points of known locations to be reviewed and verified by the Engineer to be accurate within 1 feet. Upon verification, data collection can begin. Data collection can be made as construction progresses, or can be collected after all items are installed. If the data is unacceptable the contractor shall make corrections to the data collection equipment and or process and submit the data for review and approval as specified.

Accuracy. Data collected is to be mapping grade. A handheld mapping grade GPS device shall be used for the data collection. The receiver shall support differential correction and data shall have a minimum 1-foot accuracy after post processing GPS receivers integrated into cellular communication devices, recreational and automotive GPS devices are not acceptable.

The GPS shall be the product of an established major GPS manufacturer having been in the business for a minimum of 6 years.”

Location of Underground State and County Maintained Facilities.

Revise Article 803 to read as follows.

County traffic signal facilities are not part of any of the one-call locating service such as J.U.L.I.E or Digger. If this contract requires the services of an electrical contractor, the Contractor shall be responsible at his/her own expense for locating existing IDOT and CCHD facilities prior to performing any work. If this contract does not require the services of electrical contractor, the Contractor may request one free locate for existing IDOT and CCHD electrical facilities from the Electrical Maintenance Contractor(s) prior to the start of any work. Additional requests may be at the expense of the Contractor. The location of underground traffic facilities does not relieve the Contractor of their responsibility to repair any facilities damaged during construction at their expense.

The exact location of all utilities shall be field verified by the Contractor before the installation of any components of the traffic signal system. For locations of utilities, locally owned equipment, and leased enforcement camera system facilities, the local Counties or Municipalities may need to be contacted, in the City of Chicago contact D.I.G.G.E.R. at (312) 744-7000 and for all other locations contact J.U.L.I.E. at 1-800-892-0123.

Restoration. All areas and plant material damaged by the installation of Traffic Signal posts, mast arm poles, underground cables or conduits, handholes and control cabinets shall be replaced as follows:

- Grass Areas: Replace top soil to a depth of four (4) inches (100 mm), re-grade shoulders, ditch slopes, and open areas back to former existing grades, fertilize, seed and mulch all damaged areas.
- Sod Areas (areas adjacent to residential, commercial and industrial properties and any other areas as directed by the engineer): Fertilize and re-sod damaged areas.
- Plant Materials: Remove and replace damaged trees, shrubs and vines with the same varieties that existed prior to damage.
- Shoulders other than Stabilized and Backslopes, medians, sidewalks, pavement, etc.: Replace shoulder to original condition and restore edge of backslope to original lines and grades. Medians, sidewalks and pavement shall be replaced in kind.
- All brick pavers disturbed in the work area shall be restored to their original configuration or as directed by the Engineer. All damaged brick pavers shall be replaced with a comparable material approved by the Engineer

All damaged landscape shall be replaced in accordance with Section 250 through 254 of the Standard Specifications.

Any damage, due to the installation of traffic signal equipment; or necessary removal at handholes, jacking pits, and inspection openings, of sidewalks, curbs, gutters, median and island paving, and/or pavement, shall be repaired or replaced by the Contractor. Repair or replacement shall be made with a like material of like thickness to the existing surface. Restoration of traffic signal work area shall be included in related pay items such as foundation, conduit, handhole, trench and backfill, etc.

Bagging Signal Heads.

Light tan colored traffic and pedestrian signal reusable covers shall be used to cover dark/un-energized signal sections and visors. Covers shall be made of outdoor fabric with urethane coating for repelling water, have elastic fully sewn around the cover ends for a tight fit over the visor, and have a minimum of two straps with buckles to secure the cover to the backplate. A center mesh strip allows viewing without removal for signal status testing purposes. Covers shall include a message indicating the signal is not in service.

**SPECIAL PROVISION
FOR
TRAFFIC SIGNAL POST**

Effective: 7/1/16

Revised: 5/1/21 (Remove Pedestrian Push-button Post) The furnishing and installation of this item shall meet the requirements of Sections 106.01, 875, 876, 1077.01 and 1077.02 of the Standard Specifications, except as follows:

All posts (steel), bases (cast iron), and related mounting hardware shall be hot-dipped galvanized in accordance with AASHTO M 111. A magnetic field tester may be utilized at any time to determine the thickness of galvanization. Average galvanization thickness shall be 2.0 oz. per square foot and minimum thickness shall be 1.8 oz. per square foot. The Contractor shall use a fabric post tightener to attach the post to the base. If the galvanization on the post is removed using a chain post tightener exposing bare metal, the post shall be rejected and replaced with a new post.

All iron and steel products, which are to be incorporated into work shall be domestically manufactured or produced and fabricated. The contractor shall obtain from the iron or steel producer and/or fabricator, in addition to the mill analysis, a certification that all iron or steel materials meet these domestic source requirements.

If the fabricator elects to cut and thread the post after the galvanization process, the bare metal shall immediately be cleaned to remove all cutting solvents and oils, then sprayed with two (2) coats of galvanized compound. If the Department approves painting, powder coating by the manufacturer will be required over the galvanizing.

At intersections where all the posts are not being replaced, the traffic signal base shall match existing condition (octagonal or square). Square base shall be used when all new posts and bases are installed at an intersection.

When octagonal bases are used, the bases shall be cast iron, approximately 15 inches (375 mm) high and 16 inches (400 mm) across the flat sides at the bottom. All bases shall be designed to accept four (4) 5/8" (15.6 mm) diameter anchor bolts evenly spaced in a 12-1/2" (312 mm) diameter circle.

Bases shall be cast iron and square in shape, approximately 15 inches (375 mm) high and 14 inches (350 mm) across the flat sides at the bottom. All bases shall be designed to accept four (4) 5/8" (15.6 mm) diameter anchor bolts evenly spaced between 12" (300mm) and 14" (350mm) diameter circle.

Welded extensions onto the post shall not be permitted.

Posts are to erected plumb and no shims are allowed between the bottom of the base and the foundation.

When a new post is installed on an existing foundation, the foundation shall be plumbed before the post is installed. It shall not be paid for separately but shall be included in cost for TRAFFIC SIGNAL POST..

Basis of Payment. This work will be paid for at the contract unit price EACH for TRAFFIC SIGNAL POST, GALVANIZED STEEL, of the length specified which price shall be payment in full for furnishing and installing the traffic signal post, base, foundation for pedestrian post, nuts and washers, and pipe cap complete. If the Department approves painting, powder coating by the manufacturer will be required over the galvanization in accordance with TRAFFIC SIGNAL PAINTING Special Provisions.

**SPECIAL PROVISION
FOR
CONCRETE FOUNDATION**

Effective: 7/1/16

Revised: 5/1/21 (Add a new pay item)

The installation of a concrete foundation shall meet the requirements of Section 106.01, 878 and 1006.09 of the Standard Specifications, the Standard Drawing for Concrete Foundations and District One Standard Traffic Signal Design Details with the addition as the following:

All anchor bolts shall be according to Section 1006.09, except all anchor bolts shall be hot dipped galvanized a minimum of 12 in. (300 mm) from the threaded end.

All iron and steel products, which are to be incorporated into work shall be domestically manufactured or produced and fabricated. The contractor shall obtain from the iron or steel producer and/or fabricator, in addition to the mill analysis, a certification that all iron or steel materials meet these domestic source requirements.

Foundations used for Combination Mast Arm Poles shall provide an extra 2-1/2 inch (65 mm) raceway.

No foundation is to be poured until the Resident Engineer gives approval as to the depth of the foundation.

Basis of Payment: This work will be paid for at the contract unit price per FOOT (METER) of depth for

CONCRETE FOUNDATION, TYPE A
CONCRETE FOUNDATION, TYPE A – 12" Dia.
CONCRETE FOUNDATION, TYPE C
CONCRETE FOUNDATION, TYPE D
CONCRETE FOUNDATION, TYPE E - 30" (750 mm) Dia.
CONCRETE FOUNDATION, TYPE E - 36" (900 mm) Dia.
CONCRETE FOUNDATION, TYPE E - 42" (900 mm) Dia.

which price shall be payment in full for all necessary excavating or drilling, back filling, disposal of unsuitable material, form work, ground rods and furnishing all materials within the limits of the foundation. The concrete apron in front of the cabinet and UPS shall be included in this pay item.

**SPECIAL PROVISION
FOR
FLASHING BEACON INSTALLATION, SOLAR POWERED**

This work shall consist of furnishing and installing a new solar flashing beacon, post mounted as shown on the plans and as described herein. This item shall consist of furnishing and installing two 12 inch (300 mm) L.E.D. single section amber flashing LED module on a new traffic signal post as shown on the plans or as directed by the Engineer. The signal head shall be made of polycarbonate. This item shall include furnishing and installing a flasher controller in an aluminum cabinet with discrete solar panels, LED module, battery, electronics, programmable time clock, compact housing, and be capable of operating only during school ingress and egress time with a programmable holiday schedule.

The flash pattern shall be MUTCD compliant and operate in a wig-wag fashion. The battery shall have a life span of a minimum of 5 years and be field replaceable. The battery and electronics may be located inside the solar panel housing or signal head. The sections of the flasher unit shall be secured with stainless steel hardware and unless otherwise noted, the polycarbonate housing shall be black in color.

The controller and all control equipment shall be of a manufacturer that is approved by this Department. The manufacturer shall have a representative and shop located in the six (6) county Chicago areas.

Basis of Payment. This work will be paid for at the contract unit price EACH for FLASHING BEACON INSTALLATION, SOLAR POWERED which price shall be payment in full for furnishing and installing flashing beacon solar powered complete with the necessary connections for proper operation. The traffic signal post, concrete foundation, and sign panels shall be paid for separately as TRAFFIC SIGNAL POST, CONCRETE FOUNDATION and SIGN PANEL of type specified, respectively.

**SPECIAL PROVISION
FOR
REMOVE EXISTING SIGN POST**

Description: This work shall consist of removing the existing sign post, as indicated in the plans to at least a depth of 3ft. The pay item shall cover all expenses associated with removing the sign post, associated hardware, and restoration of the work area per the Traffic Signal Work General special provision.

Basis of Payment: The work shall be paid for at contract unit price per EACH of REMOVE EXISTING SIGN POST.

**SPECIAL PROVISION
FOR
TRAFFIC CONTROL AND PROTECTION, COMPLETE**

Description: This work shall consist of providing traffic control and protection, complete within the work zone in accordance with all applicable IDOT standards for lane closures, sidewalk closures and shoulder closures. The IDOT standards include, but are not limited to, the items listed under STANDARDS below.

Standards: 701101, 701602, 701801, 701901

Basis of Payment: The work shall be paid for at contract unit price per EACH of TRAFFIC CONTROL AND PROTECTION, COMPLETE.



Interoffice

Memo

Date: March 7, 2022

To: John Urbanski, Public Works Director

From: Kelly Mulqueeny, Street Superintendent

Subject: Irrigation Maintenance - Service Contract Award-Renewal 2022 (Year 3 of 3)

Presented at the Committee of the Whole and Village Board Meetings for consideration and possible action:

Scope of Work: This service contract is a renewal to provide start up, winterization, and repair services to our irrigation systems at 3 (three) Streets Department locations and 4 (four) Facility locations that includes a total of 190 zones.

- LaGrange Road
- Harlem Avenue
- 171st Medians
- Fire Station #4
- Oak Park Ave. Metra Station
- Village Hall
- Police Station

Description: Public Works is recommending that we extend our current contract for an additional year for irrigation services on our seven (7) locations throughout Tinley Park (see above). The contract has the option of two (2)-one (1) year renewals. This would be the second (2nd) and final extension of the contract. The past year Aquamist Plumbing & Lawn Sprinkling, Inc. has proven to be professional, reliable contractor with reasonable rates.

Budget / Finance: Funding is requested in the FY23 Budget.

Budget Available	\$49,000.00
Anticipated Costs (3% increase)	\$41,660.59
Difference (under budget)	\$7,339.41

Staff Direction Request:

1. Approve the second (2nd) contract extension for Irrigation Maintenance with Aquamist Plumbing & Lawn Sprinkling, Inc. at the estimated cost of \$41,660.59 for turn on, blow out and anticipated average repairs.
2. Direct Staff as necessary.

THE VILLAGE OF TINLEY PARK
Cook County, Illinois
Will County, Illinois

RESOLUTION
NO. 2022-R-027

**A RESOLUTION APPROVING THE SECOND EXTENSION OF THE AWARDED CONTRACT
BETWEEN THE VILLAGE OF TINLEY PARK AND AQUAMIST PLUMBING AND LAWN
SPRINKLING COMPANY FOR VILLAGE OF TINLEY PARK IRRIGATION**

MICHAEL W. GLOTZ, PRESIDENT
NANCY M. O'CONNOR, VILLAGE CLERK

WILLIAM P. BRADY
WILLIAM A. BRENNAN
DIANE M. GALANTE
DENNIS P. MAHONEY
MICHAEL G. MUELLER
COLLEEN M. SULLIVAN
Board of Trustees

A RESOLUTION APPROVING THE SECOND EXTENSION OF THE AWARDED CONTRACT BETWEEN THE VILLAGE OF TINLEY PARK AND AQUAMIST PLUMBING AND LAWN SPRINKLING COMPANY FOR VILLAGE OF TINLEY PARK IRRIGATION

WHEREAS, the Village of Tinley Park, Cook and Will Counties, Illinois, is a Home Rule Unit pursuant to the Illinois Constitution of 1970; and

WHEREAS, the Corporate Authorities of the Village of Tinley Park, Cook and Will Counties, Illinois, have considered authorizing a Contract with Aquamist Plumbing and Lawn Sprinkling Company, a true and correct copy of such First Extension Contract being attached hereto and made a part hereof as **EXHIBIT 1**; and

WHEREAS, the Corporate Authorities of the Village of Tinley Park, Cook and Will Counties, Illinois, have determined that it is in the best interests of said Village of Tinley Park that said Contract be entered into by the Village of Tinley Park;

NOW, THEREFORE, Be It Resolved by the President and Board of Trustees of the Village of Tinley Park, Cook and Will Counties, Illinois, as follows:

Section 1: The Preambles hereto are hereby made a part of, and operative provisions of, this Resolution as fully as if completely repeated at length herein.

Section 2: That this President and Board of Trustees of the Village of Tinley Park hereby find that it is in the best interests of the Village of Tinley Park and its residents that the aforesaid "contract" be entered into and executed by said Village of Tinley Park, with said Contract to be substantially in the form attached hereto and made a part hereof as **EXHIBIT 1**, subject to review and revision as to form by the Village Attorney.

Section 3: That the President and Clerk of the Village of Tinley Park, Cook and Will Counties, Illinois are hereby authorized to execute for and on behalf of said Village of Tinley Park the aforesaid Contract.

Section 4: That this Resolution shall take effect from and after its adoption and approval.

ADOPTED this 5th day of April, 2022, by the Corporate Authorities of the Village of Tinley Park on a roll call vote as follows:

AYES:

NAYS:

ABSENT:

APPROVED this 5th day of April, 2022, by the President of the Village of Tinley Park.

Village President

ATTEST:

Village Clerk

EXHIBIT 1

STATE OF ILLINOIS)
COUNTY OF COOK) SS
COUNTY OF WILL)

CERTIFICATE

I, NANCY M. O’CONNOR, Village Clerk of the Village of Tinley Park, Counties of Cook and Will and State of Illinois, DO HEREBY CERTIFY that the foregoing is a true and correct copy of Resolution No. 2022-R-027, “**A RESOLUTION APPROVING THE SECOND EXTENSION OF THE AWARDED CONTRACT BETWEEN THE VILLAGE OF TINLEY PARK AND AQUAMIST PLUMBING AND LAWN SPRINKLING COMPANY FOR VILLAGE OF TINLEY PARK IRRIGATION,**” which was adopted by the President and Board of Trustees of the Village of Tinley Park on April 5, 2022.

IN WITNESS WHEREOF, I have hereunto set my hand and affixed the corporate seal of the Village of Tinley Park this 5th day of April, 2022.

VILLAGE CLERK



Consolidated High School District 230

15100 S. 94th Avenue, Orland Park, IL 60462 708-745-5203 d230.org
Dr. Robert J. Nolting, Superintendent

Vendor 003222

March 8, 2022

Mr. Pat Carr
Village Manager
Village of Tinley Park
16250 South Oak Park Avenue
Tinley Park, IL 60477

Dear Mr. Carr:

Consolidated High School District 230 is requesting you submit to us a check covering the Impact Funds received since August 1, 2021, from various developers and builders under the Village of Tinley Park's Impact Fee Ordinance.

If you have any questions, please do not hesitate to contact me.

Sincerely,

John Lavelle
Assistant Superintendent
for Business Services

JL/cg

*July 2021 to Feb 2022
84-5/10 - 73125
1,300*

B 11 Mar 2022

RAFFLE LICENSE APPLICATION



Date: _____

1. Organization name: HARALD VIKING LODGE #13

2. Organization address: 6730 W. 175TH ST.

3. Mailing address if different from above:

4. Check type of not-for-profit organization (must be in existence for a period of five years and attached documentary evidence):

- Religious
- Charitable
- Labor
- Fraternal
- Educational
- Veterans
- Business

5. How long has the organization been in existence: 1903 = 119 YEARS

6. Place and date of incorporation: CHICAGO MARCH 30, 1903

7. Number of members in good standing: 150

8. President/chairperson: BILL HENDRY

Address: _____

Phone: _____ Email: _____

9. Raffle manager: LARRY NICHOLS

Address: _____

Phone: _____ Email: _____

10. Designated member(s) responsible for conduct and operation of raffle (attached additional sheets if necessary):

Name: LARRY NICHOLS

Address: _____ Phone: _____

Name: _____

Address: _____ Phone: _____

11. License delivery option (check all that apply):

- By regular U.S. mail to the organization mailing address
- By electronic mail, please provide email address: _____

12. Date(s) for raffle ticket sales (include days of the week): MONDAY THRU SUNDAY

13. Location of ticket sales: 6730 W. 175TH ST.

14. Name and address of location for determining winners: SAME AS ABOVE

15. Date(s) for determining winners (include days of the week): TUESDAY DRAWINGS UNTIL WON

16. Total retail value of all prizes (maximum prize amount \$250,000): \$ 25,000. - VERRY'S

17. Maximum retail value of each prize: \$ _____

18. Maximum price charged of each ticket (chance) sold: \$ 1.00

19. Is this a queen of hearts raffle? No Yes

20. § 132.38 Fidelity Bond Required

All operations of and the conduct of raffles as provided for in this subchapter shall be under the supervision of a single manager designated by the organization. Such manager shall give a Fidelity bond in the sum of \$165,000 or two times the aggregate value of prizes, whichever is less, in favor of the licensee conditioned upon his honesty in the performance of his duties. The bond shall provide that notice shall be given in writing to the Village of Tinley Park not less than thirty (30) days prior to cancellation. Bonds as provided for in this section may be waived provided the license issued for such raffle shall contain a waiver provision and shall be approved only by unanimous vote of the members of the licensed organization.

Fidelity bond Waiver of bond statement by organization

"The undersigned attest that the above-named organization is an organized not-for-profit under the law of the State of Illinois and has been continuously in existence for five (5) years, preceding date of this application, and that during this entire five (5) year period preceding date of application, it has maintained a bona fide membership actively engaged in carrying out its objectives. The undersigned do hereby state under penalties of perjury that all statements in the foregoing application are true and correct; that the officers, operators and workers of the game are bona fide members of the sponsoring organization and are all of good moral character and have not been convicted of a felony; that if a license is granted hereunder, the undersigned will be responsible for the conduct of the games in accordance with the provisions of the laws of the State of Illinois and this jurisdiction governing the conduct of such games."

Name of Organization: HARALD VIKING LODGE #13

Executive Director: William D. Hendry

TO BE COMPLETED BY VILLAGE STAFF
Date Received: MAR 1 2022
Date Expires: April 5, 2023

Date Approved: _____

Date Denied: _____

Approval: _____

Village Clerk

APPROVED APPLICATION SERVES AS LICENSE

SEND

vchlist
03/24/2022 4:35:51PM

Voucher List
Village of Tinley Park

Page: 1

Bank code : ap_py

Voucher	Date	Vendor	Invoice	PO #	Description/Account	Amount
126364	3/25/2022	016864 ANTHEM BLUE CROSS BLUE SHIELD	PR000228756871		HEALTH INS-MAR PMT/APR - JUNE 86-00-000-20430	530.78
Total :						530.78
126365	3/25/2022	016864 ANTHEM BLUE CROSS BLUE SHIELD	PR000228767431		HEALTH INS-MAR PMT/APR - JUNE 86-00-000-20430	439.23
Total :						439.23
126366	3/25/2022	004640 HEALTHCARE SERVICE CORPORATION	HCSVCS-PPPR040122		A/C#271855-HEALTH INS-MAR PMT, 86-00-000-20430	20,864.79
			HCSVCS-PR040122		A/C#271855-HEALTH INS-MAR PMT, 86-00-000-20430	19,638.76
Total :						40,503.55
3 Vouchers for bank code : ap_py						Bank total : 41,473.56

vchlist
03/24/2022 4:35:51PM

Voucher List
Village of Tinley Park

Page: 2

Bank code : apbank

<u>Voucher</u>	<u>Date</u>	<u>Vendor</u>	<u>Invoice</u>	<u>PO #</u>	<u>Description/Account</u>	<u>Amount</u>
196370	3/25/2022	012659 ADVANCE AUTO PARTS	6717208073157		BRAKE HOSE 01-17-205-72540	19.46
					Total :	19.46
196371	3/25/2022	014341 AFTERMATH, INC.	JC2022-8151		BIO-HAZARD CLEANING 01-17-205-72750	155.00
					Total :	155.00
196372	3/25/2022	006514 ALPHAGRAPHICS	20016		WATER METER REPLACEMENT BO 60-00-000-72310 64-00-000-72310	302.47 129.63
					Total :	432.10
196373	3/25/2022	002424 AMERICAN WATER WORKS ASSOC	7002009912		MEMBERSHIP DUES E.RODGERS 60-00-000-72720 63-00-000-72720 64-00-000-72720	29.75 29.75 25.50
					Total :	85.00
196374	3/25/2022	020071 AMSIVE LLC	553450		MARCH 1ST'22 WATER BILLS 60-00-000-72310 64-00-000-72310	1,204.81 516.35
					Total :	1,721.16
196375	3/25/2022	016864 ANTHEM BLUE CROSS BLUE SHIELD	AP000228756871		HEALTH INS EXPENSE-MAR PMT/A 60-00-000-72435 63-00-000-72435 64-00-000-72435	312.09 59.44 159.24
					Total :	530.77
196376	3/25/2022	016864 ANTHEM BLUE CROSS BLUE SHIELD	AP000228767431		HEALTH INS EXPENSE-MAR PMT/A 60-00-000-72435 63-00-000-72435 64-00-000-72435	258.26 49.19 131.78
					Total :	439.23
196377	3/25/2022	011720 APWA	797326		APWA MEMBERSHIP : A.SCHATTKE 01-26-023-72720	205.60

vchlist
03/24/2022 4:35:51PM

Voucher List
Village of Tinley Park

Page: 3

Bank code : apbank

<u>Voucher</u>	<u>Date</u>	<u>Vendor</u>	<u>Invoice</u>	<u>PO #</u>	<u>Description/Account</u>	<u>Amount</u>
196377	3/25/2022	011720 APWA	(Continued)		60-00-000-72720	84.30
					63-00-000-72720	43.18
					64-00-000-72720	37.00
					Total :	370.08
196378	3/25/2022	016477 BARAJAS, JOHN	031722		REIMB RUBBER WHEEL CHOCK AM	
					01-21-000-72530	65.76
					01-21-000-72720	29.99
					Total :	95.75
196379	3/25/2022	010953 BATTERIES PLUS - 277	P49712299		6PK 3V LITHIUM CR1632	
					01-17-205-73600	17.78
					Total :	17.78
196380	3/25/2022	018807 BAXTER & WOODMAN INC	0231889		190816.60 LAGRANGE RD UTILITY I	
					26-00-000-75707	4,058.97
					Total :	4,058.97
196381	3/25/2022	003229 CED/EFENGEE	5025-1004307		CONNECTORS	
					01-26-024-73570	33.40
					Total :	33.40
196382	3/25/2022	015199 CHICAGO PARTS & SOUND LLC	2J0003515	VTP-019043	EMERGENCY EQUIPMENT UNIT 83	
			3-0048831		60-00-000-74232	3,325.00
					OIL FILTER - PD STOCK	
					01-17-205-72540	125.28
					Total :	3,450.28
196383	3/25/2022	003137 CHRISTOPHER B.BURKE ENGINEERNG	172473		01.R160373.D0025 DOROTY LN WA	
			172474		26-00-000-75705	9,583.50
					01.R160373.D0026 IRONWOOD DR	
					26-00-000-75704	12,153.50
					Total :	21,737.00
196384	3/25/2022	013820 CINTAS CORPORATION	5099514774		MEDICINE CABINET - PUBLIC SAFE	
			9169579054		01-26-025-73117	276.30
					MEDICINE CABINET - PD	

vchlist
03/24/2022 4:35:51PM

Voucher List
Village of Tinley Park

Page: 4

Bank code : apbank

Voucher	Date	Vendor	Invoice	PO #	Description/Account	Amount
196384	3/25/2022	013820 CINTAS CORPORATION	(Continued)			
			9169579067		01-26-025-73117 MEDICINE CABINET - PUMP HOUSE	94.02
			9169579087		01-26-025-73117 MEDICINE CABINET - PD SHOOTING	38.53
			9169579102		01-26-025-73117 MEDICINE CABINET - PUMP HOUSE	8.95
					01-26-025-73117	58.34
					Total :	476.14
196385	3/25/2022	013820 CINTAS CORPORATION	4114003533		MATS - PW	
					01-26-025-72790	275.64
					Total :	275.64
196386	3/25/2022	018475 CLARKE, KIMBERLY	032122		LUNCH REIMB,WORKING LUNCH V	
					01-33-000-72220	57.45
					Total :	57.45
196387	3/25/2022	012057 COMCAST CABLE	8771401810316240		ACCT#8771401810316240 7850 183	
					01-17-205-72517	55.40
					Total :	55.40
196388	3/25/2022	013878 COMED - COMMONWEALTH EDISON	0385181000		ACCT#0385181000 18001 80TH AVE	
			0385440022		01-26-025-72510	3,866.97
			0421064066		ACCT#0385440022 1E MEADOWB	
			0471006425		64-00-000-72510	549.91
			0637059039		ACCT#0421064066 LAPORTE RD &	
			2922039023		64-00-000-72510	276.21
			4943163008		ACCT#0471006425 19948 SILVERSI	
			5983017013		01-26-024-72510	70.12
					ACCT#0637059039 7950 W TIMBER	
					64-00-000-72510	251.91
					ACCT#2922039023 9342 PARKWOC	
					01-26-024-72510	22.71
					ACCT#4943163008 7650 TIMBER DF	
					70-00-000-72510	20.01
					ACCT#5983017013 19112 S 80TH AV	

vchlist
03/24/2022 4:35:51PM

Voucher List
Village of Tinley Park

Page: 5

Bank code : apbank

<u>Voucher</u>	<u>Date</u>	<u>Vendor</u>	<u>Invoice</u>	<u>PO #</u>	<u>Description/Account</u>	<u>Amount</u>
196388	3/25/2022	013878	COMED - COMMONWEALTH EDISON	(Continued)	63-00-000-72510	297.58
Total :						5,355.42
196389	3/25/2022	016620	COMMUNICATION ZONE, INC.	31914	TEST (4) FIBER LEGS 01-26-025-72777	2,318.93
Total :						2,318.93
196390	3/25/2022	012410	CONSERV FS, INC.	66047709	CONSERV FS SUNNY 01-26-024-73680	180.00
				66047794	SALT FOR ICE CONTROL 01-26-023-73810	3,400.00
				VTP-019039		
Total :						3,580.00
196391	3/25/2022	018234	CORE & MAIN LP	Q422323	METER COUPLING AND CONNECTI 60-00-000-73630	-230.58
						-25.62
						-109.80
				Q515366	NO LEAD BUSH BRASS 60-00-000-73630	248.62
						27.63
						118.39
Total :						28.64
196392	3/25/2022	003511	CULLIGAN WATER CONDITIONING	0050617	WATER COOLERS FD#47,48,49 01-19-000-72750	39.00
Total :						39.00
196393	3/25/2022	014690	DARLING INGREDIENTS INC	12048733	CAVALLINI'S CAFE SERVICE FEE TI 01-26-025-72530	155.00
Total :						155.00
196394	3/25/2022	004009	EAGLE UNIFORM CO INC	INV-6717	BLANKET PO FOR CLASS A UNIFO 01-19-000-73610	442.50
				INV-6721	BLANKET PO FOR CLASS B UNIFO 01-19-000-73610	218.25
				INV-6732	BLANKET PO FOR CLASS B UNIFO	

vchlist
03/24/2022 4:35:51PM

Voucher List
Village of Tinley Park

Page: 6

Bank code : apbank

<u>Voucher</u>	<u>Date</u>	<u>Vendor</u>	<u>Invoice</u>	<u>PO #</u>	<u>Description/Account</u>	<u>Amount</u>
196394	3/25/2022	004009 EAGLE UNIFORM CO INC	(Continued)			
			INV-6781	VTP-018597	01-19-000-73610	334.00
			INV-6782	VTP-018597	01-19-000-73610	558.75
				VTP-018598	01-19-000-73610	197.00
					Total :	1,750.50
196395	3/25/2022	004010 ED & JOE'S PIZZA	030422		EMPLOYEE APPRECIATION DAY - V	
					84-00-000-20199	256.15
					Total :	256.15
196396	3/25/2022	004087 EMERGENCY MEDICAL PRODUCTS INC	2326170		NASOPHARYNGEAL AIRWAY,PORC	
					01-19-000-73115	26.76
					Total :	26.76
196397	3/25/2022	004119 ETP LABS INC.	22-135825		COLIFORM SAMPLES	
					60-00-000-72865	459.20
					63-00-000-72865	196.80
					Total :	656.00
196398	3/25/2022	020451 FALCO, VITA	Ref001419201		UB Refund Cst #00456088	
					60-00-000-20599	221.04
					Total :	221.04
196399	3/25/2022	014047 FAMILY HYUNDAI	032222		6TH ANNUAL INCENTIVE	
					01-97-000-79126	62,051.66
					Total :	62,051.66
196400	3/25/2022	018480 FARNSWORTH GROUP	231988		0170121.30 VTP-ATLAS PUTTY#30	
					01-33-310-72847	742.50
					Total :	742.50
196401	3/25/2022	018255 FCA REALTY LLC	032222		6TH ANNUAL INCENTIVE	
					01-97-000-79143	412,022.00
					Total :	412,022.00
196402	3/25/2022	004176 FEDEX (FEDERAL EXPRESS)	768519757		ACCT#768519757 SHPPING COSTS	

vchlist
03/24/2022 4:35:51PM

Voucher List
Village of Tinley Park

Page: 7

Bank code : apbank

<u>Voucher</u>	<u>Date</u>	<u>Vendor</u>	<u>Invoice</u>	<u>PO #</u>	<u>Description/Account</u>	<u>Amount</u>
196402	3/25/2022	004176 FEDEX (FEDERAL EXPRESS)	(Continued)		01-13-000-72110	53.83
					01-14-000-72110	28.55
					Total :	82.38
196403	3/25/2022	015058 FLEETPRIDE	94610388		FILTERS	
			96456334		01-26-023-72540	111.44
					FUSE	
					60-00-000-72540	2.43
					63-00-000-72540	0.81
					64-00-000-72540	1.40
					Total :	116.08
196404	3/25/2022	020195 FOREST PRINTING COMPANY	110334		BUSINESS CARDS - J BLAKEY	
					01-33-000-72310	43.50
					Total :	43.50
196405	3/25/2022	020426 FRIGO, RUTH	Ref001419202		UB Refund Cst #00476140	
					60-00-000-20599	195.20
					Total :	195.20
196406	3/25/2022	019349 GARVEY'S OFFICE PRODUCTS	PINV2230953		LABELS	
					01-19-000-73110	70.50
					Total :	70.50
196407	3/25/2022	004438 GRAINGER	9244147295		SQUEEGEE,SOAP DISPENSER,HOC	
					01-19-000-73580	780.46
					01-19-000-72524	261.38
			9244480555		HAND SOAP	
					01-19-000-73580	599.49
			9248888597		SQUEEGEE,VAC HOSE	
					01-26-025-73580	204.73
					Total :	1,846.06
196408	3/25/2022	004640 HEALTHCARE SERVICE CORPORATION	HCSVCS-AP040122		A/C#271855-HEALTH INS EXPENSE	
					01-15-000-72435	407.36
					01-16-000-72435	836.08

vchlist
03/24/2022 4:35:51PM

Voucher List
Village of Tinley Park

Page: 8

Bank code : apbank

<u>Voucher</u>	<u>Date</u>	<u>Vendor</u>	<u>Invoice</u>	<u>PO #</u>	<u>Description/Account</u>	<u>Amount</u>
196408	3/25/2022	004640	HEALTHCARE SERVICE CORPORATION (Continued)		01-19-020-72435	407.36
					01-21-210-72435	318.22
					64-00-000-72435	95.47
					63-00-000-72435	35.64
					60-00-000-72435	187.11
					01-26-025-72435	174.58
					60-00-000-72435	102.67
					63-00-000-72435	19.56
					64-00-000-72435	52.35
					01-26-025-72435	836.08
					01-26-023-72435	1,339.73
					60-00-000-72435	729.91
					64-00-000-72435	372.40
					63-00-000-72435	139.03
					01-26-023-72435	1,241.34
					01-26-024-72435	1,378.12
					60-00-000-72430	-0.13
			HCSVCS-PPAP040122		A/C#271855-HEALTH INS EXP-MAR	
					01-17-205-72435	28,863.53
					Total :	37,536.41
196409	3/25/2022	012281	HINCKLEY SPRINGS	5977593031922	ACCT#32542175977593 WATER CO	
					01-21-210-73110	191.78
					Total :	191.78
196410	3/25/2022	001487	HOMEWOOD DISPOSAL SERVICE	7758775	30YD EXCHANGE,DUMP CHARGES	
					01-26-023-72890	447.24
					Total :	447.24
196411	3/25/2022	016048	HRUBY, RYAN	032122	PER DIEM: LUNCH,GAS ACCIDENT	
					01-17-220-72140	180.00
					Total :	180.00
196412	3/25/2022	005160	ILLINOIS STATE POLICE	CC04004	CC4004 TINLEY FINGERPRINT VILL	
					01-14-000-72848	28.25

vchlist
03/24/2022 4:35:51PM

Voucher List
Village of Tinley Park

Page: 9

Bank code : apbank

<u>Voucher</u>	<u>Date</u>	<u>Vendor</u>	<u>Invoice</u>	<u>PO #</u>	<u>Description/Account</u>	<u>Amount</u>
196412	3/25/2022	005160	005160 ILLINOIS STATE POLICE		(Continued)	Total : 28.25
196413	3/25/2022	005025	INTERNATIONAL CODE COUNCIL INC	1001442967	SPRINKLER REVIEW 7061 159TH S 01-33-300-72844	1,500.00
				1001448404	PLAN REVIEW -16300 HARLEM AVE 01-33-300-72844	1,550.00
				1001455244	SPRINKLER REVIEW 34 OLYMPUS 01-33-300-72844	1,000.00
				1001477961	SPRINKLER REVIEW 19501 HARLE 01-33-300-72844	2,376.00
					Total :	6,426.00
196414	3/25/2022	005186	INTERSTATE BATTERY SYSTEM	10074983	SLA1005 POLICE STOCK 01-17-205-72540	111.80
				10074999	M-65HC BATTERY WATER #97 60-00-000-72540	56.18
					63-00-000-72540	18.73
					64-00-000-72540	32.09
				313463	SLA1005 BATTERY PD - STOCK 01-17-205-72540	139.75
					Total :	358.55
196415	3/25/2022	005251	J AND R SALES AND SERVICE INC.	0347706	SAWCHAIN SHARPEN, CHAIN LOOI 01-26-023-73410	281.63
					Total :	281.63
196416	3/25/2022	007233	JOLIET SUSPENSION, INC.	130877	LEAF SPRING,CENTER BOLT,METF 01-26-023-72540	1,380.96
					Total :	1,380.96
196417	3/25/2022	005349	KORTUM, LISA	031822	REIMB WORK SHIRTS 01-21-210-73610	36.49
					Total :	36.49
196418	3/25/2022	014846	LORENCE, BRUCE	040122	APR'22 OPA TRAIN STATION MAINT 01-26-025-72530	30.00
					Total :	30.00

vchlist
03/24/2022 4:35:51PM

Voucher List
Village of Tinley Park

Page: 10

Bank code : apbank

<u>Voucher</u>	<u>Date</u>	<u>Vendor</u>	<u>Invoice</u>	<u>PO #</u>	<u>Description/Account</u>	<u>Amount</u>
196419	3/25/2022	013858 LOWE'S HOME CENTER, INC.	032322		MAILBOXES 01-26-023-73840	437.76
Total :						437.76
196420	3/25/2022	003440 M. COOPER WINSUPPLY CO.	07982501		PS PARTS PERFORMANCE KIT- SLI 01-26-025-73630	63.58
			08529201		SRG TANK TO BOWL GASKET,REP/	77.64
			08543501		MUNICIPAL BLDG - URINAL REPAIR 01-26-025-73630	95.37
Total :						236.59
196421	3/25/2022	013969 MAP AUTOMOTIVE OF CHICAGO	030922		OVERPAYMENT CK#190291 FOR IN 01-17-205-72540	-9.00
			40-657943		CORE,BATTERY RETURN 01-17-205-72540	-163.08
			40-658726		BATTERY PD#28B,11B,24B 01-17-205-72540	355.50
Total :						183.42
196422	3/25/2022	020322 MASTER AUTO SUPPLY	15030-115211		STABILIZER BAR LINK PD 2B 01-17-205-72540	43.30
			15030-115422		STAB BAR BUSHING KIT DODGE C/	7.19
					60-00-000-72540	2.40
					63-00-000-72540	4.10
			15030-115423		CRANKCASE BREATHER - STREET 01-26-023-72540	49.06
Total :						106.05
196423	3/25/2022	006074 MENARDS	18955		FLR PAINT ANTISKID, QS 9"X3/8" 3P 01-26-023-73620	72.95
			19186		MAILBOX,PLIER,UTILITY BAR 01-26-023-73840	167.90
			19211		MAILBOX 01-26-023-73840	454.17
			19272		MAILBOXES	

vchlist
03/24/2022 4:35:51PM

Voucher List
Village of Tinley Park

Page: 11

Bank code : apbank

<u>Voucher</u>	<u>Date</u>	<u>Vendor</u>	<u>Invoice</u>	<u>PO #</u>	<u>Description/Account</u>	<u>Amount</u>
196423	3/25/2022	006074	MENARDS			
			(Continued)			
			19301		01-26-023-73840 WL K&B SILICON ULTRA WHITE	357.60
			19302		01-26-025-72520 EYE BOLT	12.98
					60-00-000-73840	1.03
					63-00-000-73840	0.34
					64-00-000-73840	0.59
			19303		BYPASS LOPPER,GRINDER,TAPER	
					60-00-000-73410	96.42
					64-00-000-73410	45.91
					63-00-000-73410	10.71
			19306		BUNGEE ASSORT SS 5PCS	
					01-26-024-73845	7.11
					01-26-023-73845	14.22
					60-00-000-73845	8.96
					63-00-000-73845	1.00
					64-00-000-73845	4.25
			19316		VOGT PLAZA OULETS -20A ST GFC	
					01-26-024-73570	151.32
			19320		2X3 10' DOWNSPOUT	
					01-26-025-72520	11.48
			19321		PREMIUM TOP SOIL	
					60-00-000-73680	3.77
					63-00-000-73680	0.42
					64-00-000-73680	1.79
			19374		MAILBOXES	
					01-26-023-73840	269.96
			19375		UTILITY KNIFE,DIA BRD POLYES,BY	
					60-00-000-73410	36.63
					63-00-000-73410	4.07
					64-00-000-73410	17.44
			19376		PREMIUM TOP SOIL	
					60-00-000-73680	3.77
					63-00-000-73680	0.42
					64-00-000-73680	1.79

vchlist
03/24/2022 4:35:51PM

Voucher List
Village of Tinley Park

Page: 12

Bank code : apbank

<u>Voucher</u>	<u>Date</u>	<u>Vendor</u>	<u>Invoice</u>	<u>PO #</u>	<u>Description/Account</u>	<u>Amount</u>
196423	3/25/2022	006074	006074 MENARDS		(Continued)	Total : 1,759.00
196424	3/25/2022	005664	MORTON SALT INC	5402545167	ROAD SALT 3/15/21	
				VTP-018790	01-26-023-73810	1,552.19
				VTP-018790	70-00-000-73810	57.79
				VTP-018790	08-00-000-73810	41.29
					Total :	1,651.27
196425	3/25/2022	006226	NFPA	8151376X	ID#2029335 SUBRSRIPTION RENEV	
					01-19-000-72720	1,345.50
					Total :	1,345.50
196426	3/25/2022	015723	NICOR	33079168366	ACCT#33079168366 METER 438535	
					64-00-000-72511	51.03
				49924710004	ACCT#49924710004 METER 458175	
					01-26-025-72511	652.61
				64423710009	ACCT#64423710009 METER 335839	
					01-26-025-72511	1,838.91
				81423710003	ACCT#81423710003 METER#28316	
					01-26-025-72511	172.72
					Total :	2,715.27
196427	3/25/2022	016402	NORTHAMERICAN REPTILE BREEDERS	032222	CONVENTION CENTER INCENTIVE	
					12-00-000-72986	6,000.00
					Total :	6,000.00
196428	3/25/2022	020444	OBERHOLZ, MICHAEL	031022	REIMB CPR ONLINE CLASS	
					01-21-000-72140	15.00
					Total :	15.00
196429	3/25/2022	010135	ONSITE COMMUNICATIONS USA, INC	51772	VHF GLASS MOUNT ANTENNA	
					60-00-000-72540	40.95
					63-00-000-72540	13.65
					64-00-000-72540	23.40
				51773	ADDING PUBLIC SAFETY CHANNEL	
					01-26-024-72550	57.00
					01-26-023-72550	114.00
					60-00-000-72550	39.90

vchlist
03/24/2022 4:35:51PM

Voucher List
Village of Tinley Park

Page: 13

Bank code : apbank

<u>Voucher</u>	<u>Date</u>	<u>Vendor</u>	<u>Invoice</u>	<u>PO #</u>	<u>Description/Account</u>	<u>Amount</u>
196429	3/25/2022	010135	ONSITE COMMUNICATIONS USA, INC	(Continued)		
					63-00-000-72550	39.90
					64-00-000-72550	34.20
					Total :	363.00
196430	3/25/2022	013096	PACE SYSTEMS INC	212062	CONVENTION CENTER CCTV SER\	
					01-26-025-72520	666.67
					Total :	666.67
196431	3/25/2022	006714	PAPER DIRECT INC.	1974452	BORDER GLD/WHT CERT 38# 1UP	
					01-14-000-73110	368.46
					Total :	368.46
196432	3/25/2022	006475	PARK ACE HARDWARE	067610/1	ACCT#9633 INV#067610/1 DOUBLE	
					01-17-205-73600	34.14
					Total :	34.14
196433	3/25/2022	017268	PETERSON JOHNSON & MURRAY	136099	4130.001 LEGAL SVC GENERAL MA	
					01-14-000-72850	36,502.50
				136102	4130.0022 NEW BREMEN TIF SVC T	
					27-00-000-72850	8,490.00
				136103	4130.0025 LEGAL SVC TP 2019 NO	
					01-14-000-72850	2,709.00
				136105	4130.0031 TP EMINENT DOMAIN SV	
					27-00-000-72850	5,023.00
				136106	4130.0042 LEGAL SVC 7050 171ST :	
					01-14-000-72850	86.00
				136109	4130.0048 LEGAL SVC LOYOLA UN	
					01-14-000-72850	2,190.00
				136110	4130.0050 LEGAL SVC LINCOLNWA	
					01-14-000-72850	6,420.00
					Total :	61,420.50
196434	3/25/2022	006499	PITNEY BOWES INC	1020258099	ACCT#0012198182 SLA TIER2-EQU	
					01-14-000-72750	226.35
					60-00-000-72750	226.35
					Total :	452.70

vchlist
03/24/2022 4:35:51PM

Voucher List
Village of Tinley Park

Page: 14

Bank code : apbank

<u>Voucher</u>	<u>Date</u>	<u>Vendor</u>	<u>Invoice</u>	<u>PO #</u>	<u>Description/Account</u>	<u>Amount</u>
196435	3/25/2022	006780 POMP'S TIRE SERVICE, INC	410983722	VTP-019030	(4) 265-65TR18 FORTITUDE TIRES I 01-19-000-72570	488.76 Total : 488.76
196436	3/25/2022	006507 POSTMASTER, U. S. POST OFFICE	032122		PERMIT#6 VEHICLE STICKER 2022 06-00-000-72110	9,227.26 Total : 9,227.26
196437	3/25/2022	013587 PROSHRED SECURITY	990111997		SHREDDING SERVICES - PD 01-17-205-72750	169.60 Total : 169.60
196438	3/25/2022	006361 RAY O' HERRON CO INC	2181906 2181907		GAS MASK CARRIER 01-17-220-73610 GAS MASK CARRIER 01-17-220-73610	38.94 29.95 Total : 68.89
196439	3/25/2022	020429 RESCUE SOLUTIONS CORPORATION	22-1205	VTP-019048	TRAINING- 4 DAY "SPECIAL ENTRA 01-19-000-72140	4,200.00 Total : 4,200.00
196440	3/25/2022	020448 RONS, MICHELE	032222		REIMB FOR IRISH PARADE CANDY 01-41-057-72220	22.03 Total : 22.03
196441	3/25/2022	007629 SAM'S CLUB DIRECT	031722		WATER,SUGAR,SODA 01-14-000-73115 01-26-023-73115 01-26-024-73115 60-00-000-73115 63-00-000-73115 64-00-000-73115	22.96 26.30 13.15 9.21 9.20 7.90 Total : 88.72
196442	3/25/2022	007224 STANDARD EQUIPMENT COMPANY	P34666 P34707		LUBE,FUEL,AIR,OIL FILTER STREE 01-26-023-72540 LUBE,AIR,FUEL, OIL FILTERS STRE	527.64

vchlist
03/24/2022 4:35:51PM

Voucher List
Village of Tinley Park

Page: 15

Bank code : apbank

<u>Voucher</u>	<u>Date</u>	<u>Vendor</u>	<u>Invoice</u>	<u>PO #</u>	<u>Description/Account</u>	<u>Amount</u>
196442	3/25/2022	007224	STANDARD EQUIPMENT COMPANY	(Continued)		
				P34744	01-26-023-72540 WLDT LOOP STREETS #90AUX	739.11
				P34778	01-26-023-72540 SELECTOR SWITCH UNIT 7	133.28
					01-26-023-72540	68.34
					Total :	1,468.37
196443	3/25/2022	012238	STAPLES BUSINESS ADVANTAGE	3502481592	FILE FOLDER A-Z	
					01-15-000-73110	32.49
				3502481593	ENVELOPES	
					01-14-000-73110	14.99
				3502481594	PINK PAPER	
					01-17-205-73110	39.98
					Total :	87.46
196444	3/25/2022	015452	STEINER ELECTRIC COMPANY	S007100947.001	FUSE,SPLICE,SCREWDRIVER KIT,I	
					01-26-024-73570	423.29
				S007100967.001	FUSE	
					01-26-024-73570	443.44
				S007103236.001	MULTIPLE WIRE TERM	
					01-26-024-73570	160.72
					Total :	1,027.45
196445	3/25/2022	007297	SUTTON FORD INC./FLEET SALES	548763	PUMP ASY,GASKET,BELT CHAIN,AF	
					01-17-205-72540	347.98
				549080	SEATBELT ASY PD 8S	
					01-17-205-72540	85.64
				549334	HANDLE ASY PD 11B	
					01-17-205-72540	25.12
					Total :	458.74
196446	3/25/2022	017520	THE COP FIRE SHOP	116749	BLACK POLO S/S,HAT - J. THOMP	
					01-17-205-73610	66.85
					Total :	66.85
196447	3/25/2022	020441	THE DRAW LLC	031822	BENCHES ON THE AVENUE ARTIST	

vchlist
03/24/2022 4:35:51PM

Voucher List
Village of Tinley Park

Page: 16

Bank code : apbank

<u>Voucher</u>	<u>Date</u>	<u>Vendor</u>	<u>Invoice</u>	<u>PO #</u>	<u>Description/Account</u>	<u>Amount</u>
196447	3/25/2022	020441 THE DRAW LLC	(Continued)		01-35-000-72923	425.00
					Total :	425.00
196448	3/25/2022	007777 THOMPSON ELEVATOR INSPECTION	22-0726		R&R MOD PERMIT INSPECTION,2 E 01-33-300-72853	151.00
					Total :	151.00
196449	3/25/2022	012187 TOTAL AUTOMATION CONCEPTS, INC	W27743	VTP-018663	MULTI-ZONE AHU REPLACEMENT 1 01-26-025-72530	10,940.00
			W28100		FIRE STATION #1 BASEMENT VVT A 01-26-025-72520	1,121.40
					Total :	12,061.40
196450	3/25/2022	004106 TYLER TECHNOLOGIES INC	025-371142		INCODE COURT ANNUAL FEES 5/1/ 01-17-205-72655	2,031.52
					Total :	2,031.52
196451	3/25/2022	008040 UNDERGROUND PIPE & VALVE CO	053707		MAIN BREAK CLAMPS	
				VTP-019034	60-00-000-73630	652.68
				VTP-019034	63-00-000-73630	72.52
				VTP-019034	64-00-000-73630	310.80
				VTP-019034	60-00-000-73630	225.54
				VTP-019034	63-00-000-73630	25.06
				VTP-019034	64-00-000-73630	107.40
				VTP-019034	60-00-000-73630	333.27
				VTP-019034	63-00-000-73630	37.03
				VTP-019034	64-00-000-73630	158.70
					Total :	1,923.00
196452	3/25/2022	007987 UNITED METHODIST CHURCH	040122		APR'22 PARKING RENTAL 70-00-000-72621	1,200.00
					Total :	1,200.00
196453	3/25/2022	008011 URBANSKI, JOHN	032122		REIMB LUNCH NEW HIRE N.BARTE 60-00-000-72170	21.70
					63-00-000-72170	21.70

vchlist
03/24/2022 4:35:51PM

Voucher List
Village of Tinley Park

Page: 17

Bank code : apbank

<u>Voucher</u>	<u>Date</u>	<u>Vendor</u>	<u>Invoice</u>	<u>PO #</u>	<u>Description/Account</u>	<u>Amount</u>
196453	3/25/2022	008011 URBANSKI, JOHN	(Continued)		64-00-000-72170	18.60
					Total :	62.00
196454	3/25/2022	008057 USA BLUE BOOK	906725		RUSTOLEUM PAINT	
					60-00-000-73620	84.88
					63-00-000-73620	84.88
					64-00-000-73620	72.76
					Total :	242.52
196455	3/25/2022	018809 VAN SCHOUWEN, VINCE	032322		LUNCH PER DIEM INTERVIEW/INTE	
					01-17-220-72140	60.00
					Total :	60.00
196456	3/25/2022	006362 VILLAGE OF OAK LAWN	7787		IEPA HARKER BOND PAY REIMB L1	
			7795		60-00-000-73221	97,466.93
					IEPA BOOSTER BOND REIMB L17-5	
					60-00-000-73221	23,878.72
					Total :	121,345.65
196457	3/25/2022	006429 VILLAGE OF ORLAND HILLS	032222		21ST IGA PAYMENT	
					01-97-000-79125	24,737.98
					Total :	24,737.98
196458	3/25/2022	020100 VOLANTI, PAMELA	032322		REIMB SUPPLIES FOR ST.PATRICK	
					60-00-000-73870	17.63
					63-00-000-73870	17.63
					64-00-000-73870	15.12
					01-26-023-73870	50.38
					01-26-024-73870	25.18
					Total :	125.94
196459	3/25/2022	010165 WAREHOUSE DIRECT WORKPL SOLTNS	5167991-0		IT OFFICE FURNITURE	
				VTP-018968	01-26-025-74110	11,979.83
					01-26-025-74110	2,000.00
			5191778-0		RUBBERBANDS	
					60-00-000-73110	4.16

vchlist
03/24/2022 4:35:51PM

Voucher List
Village of Tinley Park

Page: 18

Bank code : apbank

<u>Voucher</u>	<u>Date</u>	<u>Vendor</u>	<u>Invoice</u>	<u>PO #</u>	<u>Description/Account</u>	<u>Amount</u>	
196459	3/25/2022	010165 WAREHOUSE DIRECT WORKPL SOLTNS (Continued)					
					63-00-000-73110	0.46	
					64-00-000-73110	1.98	
			5191854-0		MONITOR STAND		
					01-26-024-73110	8.39	
					01-26-023-73110	16.78	
					60-00-000-73110	10.57	
					63-00-000-73110	1.17	
					64-00-000-73110	5.05	
			C5191778-0		RETURN- RUBBERBANDS		
					01-26-024-73110	-1.32	
					01-26-023-73110	-2.64	
					60-00-000-73110	-1.66	
					63-00-000-73110	-0.18	
					64-00-000-73110	-0.80	
					Total :	14,021.79	
196460	3/25/2022	020445 WERR, LEO	031022		REIMB CPR ONLINE CLASS		
					01-21-000-72140	15.00	
					Total :	15.00	
196461	3/25/2022	011057 WEX BANK	79430356		MONTHLY WEX CARD CHARGE 2/1		
					01-14-000-72720	24.00	
					Total :	24.00	
196462	3/25/2022	017955 WILSON BOHANNAN PADLOCK CO	0189705-IN		LOCK/KEYS		
					01-26-025-73840	111.35	
					Total :	111.35	
196463	3/25/2022	020446 WOJCIK, DAVID	031122		REFUND CRIME FREE LICENSE PA		
					01-14-000-79099	50.00	
					Total :	50.00	
94 Vouchers for bank code : apbank						Bank total :	846,182.85

vchlist
03/24/2022 4:35:51PM

Voucher List
Village of Tinley Park

Page: 19

Bank code : ipmq

<u>Voucher</u>	<u>Date</u>	<u>Vendor</u>	<u>Invoice</u>	<u>PO #</u>	<u>Description/Account</u>	<u>Amount</u>
3904	3/22/2022	018837	INSURANCE PROGRAM MANAGERS GR	200803W006	PAYEE-ENCOMPASS SPECIALTY NE 01-14-000-72542	104.37 Total : 104.37
3905	3/22/2022	018837	INSURANCE PROGRAM MANAGERS GR	200803W006-1	PAYEE-ENCOMPASS SPECIALTY NE 01-14-000-72542	158.73 Total : 158.73
3906	3/22/2022	018837	INSURANCE PROGRAM MANAGERS GR	210731W002	PAYEE-ENCOMPASS SPECIALTY NE 60-00-000-72542 63-00-000-72542 64-00-000-72542	52.67 10.03 26.87 Total : 89.57
3907	3/22/2022	018837	INSURANCE PROGRAM MANAGERS GR	211026W032	PAYEE-PETERSON, JOHNSON & MI 01-14-000-72542	1,225.50 Total : 1,225.50
3908	3/22/2022	018837	INSURANCE PROGRAM MANAGERS GR	211026W032-1	PAYEE-PETERSON, JOHNSON & MI 01-14-000-72542	1,483.50 Total : 1,483.50
3909	3/22/2022	018837	INSURANCE PROGRAM MANAGERS GR	211026W032-2	PAYEE-PETERSON, JOHNSON & MI 01-14-000-72542	1,935.00 Total : 1,935.00
3910	3/22/2022	018837	INSURANCE PROGRAM MANAGERS GR	190326W026	PAYEE-PETERSON JOHNSON & ML 01-14-000-72542	2,537.00 Total : 2,537.00
3911	3/22/2022	018837	INSURANCE PROGRAM MANAGERS GR	210421W008	PAYEE-VILLAGE OF TINLEY PARK 01-14-000-72542	1,704.52 Total : 1,704.52
3912	3/22/2022	018837	INSURANCE PROGRAM MANAGERS GR	200803W006-2	PAYEE-VILLAGE OF TINLEY PARK 01-14-000-72542	1,113.02 Total : 1,113.02

vchlist
03/24/2022 4:35:51PM

Voucher List
Village of Tinley Park

Bank code : ipmq

Voucher	Date	Vendor	Invoice	PO #	Description/Account	Amount
3913	3/22/2022	018837	INSURANCE PROGRAM MANAGERS GR	210421W008	PAYEE-IPMG 01-14-000-72542	42.46
Total :						42.46
10 Vouchers for bank code : ipmq						Bank total : 10,393.67
107 Vouchers in this report						Total vouchers : 898,050.08

The Tinley Park Village Board having duly met at Village Hall do hereby certify that the following claims or demands against said village were presented and are approved for payment as presented on the above listing.

In witness thereof, the Village President and Clerk of the Village of Tinley Park, hereunto set their hands.

_____ Village President

_____ Village Clerk

_____ Date

vchlist
03/17/2022 4:30:36PM

Voucher List
Village of Tinley Park

Page: 1

Bank code : ap_ff

<u>Voucher</u>	<u>Date</u>	<u>Vendor</u>	<u>Invoice</u>	<u>PO #</u>	<u>Description/Account</u>	<u>Amount</u>
21522	2/15/2022	000339 BEST BUY CO., INC.	BBY01-806596525551		VIKING MICROWAVE, STAINLESS 36-00-000-75129	812.67
Total :						812.67
1 Vouchers for bank code : ap_ff						Bank total : 812.67

vchlist
03/17/2022 4:30:36PM

Voucher List
Village of Tinley Park

Page: 2

Bank code : ap py

<u>Voucher</u>	<u>Date</u>	<u>Vendor</u>	<u>Invoice</u>	<u>PO #</u>	<u>Description/Account</u>	<u>Amount</u>
126361	3/18/2022	003127 BLUE CROSS BLUE SHIELD	BCBS-NA-PPPR040122		IL065LB000001212-0 HEALTH INS E 86-00-000-20430	1,165.00
			BCBS-NA-PR040122		IL065LB000001212-0 HEALTH INS E 86-00-000-20430	2,099.00
Total :						3,264.00
126362	3/18/2022	019214 BLUE CROSS BLUE SHIELD	BCBS-DA-PPPR040122		IL065LB000001212-0 HEALTH INS E 86-00-000-20430	569.52
			BCBS-DA-PR040122		0000ILLB1212 HEALTH INS EXP-MA 86-00-000-20430	378.03
Total :						947.55
126363	3/18/2022	002613 UNITED HEALTHCARE AARP	AARP -PPPR040122		AARP POLICE PENSION MAR PMT/ 86-00-000-20430	3,273.26
Total :						3,273.26
3 Vouchers for bank code : ap_py						Bank total : 7,484.81

vchlist
03/17/2022 4:30:36PM

Voucher List
Village of Tinley Park

Page: 3

Bank code : apbank

<u>Voucher</u>	<u>Date</u>	<u>Vendor</u>	<u>Invoice</u>	<u>PO #</u>	<u>Description/Account</u>	<u>Amount</u>
196275	3/18/2022	010955 A T & T LONG DISTANCE	827776689		CORPORATE ID931719LB TIP LINE 01-17-225-72120	40.91 Total : 40.91
196276	3/18/2022	014341 AFTERMATH, INC.	JC2022-9437		BIOHAZARD CLEANING 01-17-205-72750	155.00 Total : 155.00
196277	3/18/2022	002734 AIR ONE EQUIPMENT, INC	178468		CAIRNS 6' FRONT F51 01-19-000-74619	40.00 Total : 40.00
196278	3/18/2022	002424 AMERICAN WATER WORKS ASSOC	7002009915		AWWA MEMBERSHIP A.SCHATTKE 01-26-023-72720 60-00-000-72720	158.67 79.33 Total : 238.00
196279	3/18/2022	020071 AMSIVE LLC	552920	VTP-018853	SIZE #10 ENVELOPE FOR WATER E 60-00-000-72310	3,008.25
				VTP-018853	64-00-000-72310	1,289.25
			552921		RETURN ENVELOPES/LATE NOTICI	
				VTP-018900	60-00-000-72310	4,272.09
				VTP-018900	63-00-000-72310	1,830.89
					Total :	10,400.48
196280	3/18/2022	020439 ATLAS INDUSTRIES	Ref001418951		UB Refund Cst #00512356 60-00-000-20599	600.00 Total : 600.00
196281	3/18/2022	019720 BEACON TRAINING GROUP LLC	1066	VTP-018985	RESCUE TASK FORCE TRAINING S 01-17-220-73600	831.95 Total : 831.95
196282	3/18/2022	003015 BEHRENS, JERRY	AP040122		JERRY BEHRENS HEALTH INSURAI 01-17-205-72435	169.00 Total : 169.00
196283	3/18/2022	020280 BETTENHAUSEN & ASSOCIATES LLC	031222		FINANCIAL AND ADMIN PROF SVC '	

vchlist
03/17/2022 4:30:36PM

Voucher List
Village of Tinley Park

Page: 4

Bank code : apbank

<u>Voucher</u>	<u>Date</u>	<u>Vendor</u>	<u>Invoice</u>	<u>PO #</u>	<u>Description/Account</u>	<u>Amount</u>
196283	3/18/2022	020280 BETTENHAUSEN & ASSOCIATES LLC	(Continued)		01-15-000-72790	6,450.00
					Total :	6,450.00
196284	3/18/2022	016817 BEVERLY SNOW AND ICE INC	54494		MUNICIPAL PARKING LOT SNOW R	
				VTP-018789	01-26-023-72785	53,160.00
				VTP-018789	70-00-000-72740	27,600.00
					Total :	80,760.00
196285	3/18/2022	003127 BLUE CROSS BLUE SHIELD	BCBS-NA-AP040122		IL065LB000001212-0 HEALTH INS E	
					01-33-300-72435	133.00
					60-00-000-72435	70.27
					63-00-000-72435	13.38
					64-00-000-72435	35.85
					60-00-000-72435	70.27
					63-00-000-72435	13.38
					64-00-000-72435	35.85
					60-00-000-72435	70.27
					63-00-000-72435	13.38
					64-00-000-72435	35.85
					60-00-000-72435	78.21
					63-00-000-72435	14.89
					64-00-000-72435	39.90
					01-12-000-72435	140.00
					01-19-020-72435	291.00
					01-26-023-72435	396.50
					01-33-300-72435	106.50
					60-00-000-72435	66.44
					63-00-000-72435	12.66
					64-00-000-72435	33.90
					60-00-000-72435	70.27
					63-00-000-72435	13.38
					64-00-000-72435	35.85
			BCBS-NA-PPAP040122		IL065LB000001212-0 HEALTH INS E	
					01-17-205-72435	1,165.00
					Total :	2,956.00

vchlist
03/17/2022 4:30:36PM

Voucher List
Village of Tinley Park

Page: 5

Bank code : apbank

<u>Voucher</u>	<u>Date</u>	<u>Vendor</u>	<u>Invoice</u>	<u>PO #</u>	<u>Description/Account</u>	<u>Amount</u>
196286	3/18/2022	019214 BLUE CROSS BLUE SHIELD	BCBS-DA-AP040122		0000ILLB1212 HEALTH INS EXP-MA 60-00-000-72435 64-00-000-72435 63-00-000-72435 01-26-023-72435 01-33-300-72435 01-26-024-72435	43.38 22.13 8.26 150.98 67.48 85.78
			BCBS-DA-PPAP040122		0000ILLB1212 HEALTH INS EXP-MA 01-17-205-72435	569.50
Total :						947.51
196287	3/18/2022	012966 BOLING, THOMAS	02-22		SHAREPOINT MAINTENANCE FEB'2 01-16-000-72650	1,500.00
Total :						1,500.00
196288	3/18/2022	003243 CDW GOVERNMENT INC	S912759		STARTECH FTDI USB TO SERIAL AI 60-00-000-72528 63-00-000-72528	15.50 15.50
			S928601		5 LENOVO THNKPADS 01-16-000-74128	7,750.00
			T242579		LOGITECH WEBCAM 01-16-000-74128	326.35
			T265441		WD 4TB MY PASSPORT PORTABLE 60-00-000-72528 63-00-000-72528	51.85 51.84
			T308316		WD 4TB MY PASSPORT PORTABLE 60-00-000-73630 63-00-000-73630	54.20 54.19
Total :						8,319.43
196289	3/18/2022	015199 CHICAGO PARTS & SOUND LLC	2J0003501		VERN REPAIR DOOR PANEL POLIC 01-17-205-72540	80.00
			3-0048602		SYN BLEND OIL VILLAGE BUS 2 01-42-000-72540	33.48
Total :						113.48
196290	3/18/2022	018325 CHICAGO TRIBUNE COMPANY LLC	74072186		SUBSCRIPTION THRU 5/27/22	

vchlist
03/17/2022 4:30:36PM

Voucher List
Village of Tinley Park

Page: 6

Bank code : apbank

<u>Voucher</u>	<u>Date</u>	<u>Vendor</u>	<u>Invoice</u>	<u>PO #</u>	<u>Description/Account</u>	<u>Amount</u>
196290	3/18/2022	018325 CHICAGO TRIBUNE COMPANY LLC	(Continued)		01-14-000-72720	103.50
					Total :	103.50
196291	3/18/2022	013820 CINTAS CORPORATION	4111692608		MATS - VH	
			4112918976		01-26-025-72790	210.33
			4113052980		MATS - PD	
					01-26-025-72790	111.81
					MATS - VH	
					01-26-025-72790	210.33
					Total :	532.47
196292	3/18/2022	017298 COMCAST BUSINESS	141511948		ACCT 930890410 VILLAGE HALL FIE	
				VTP-018478	01-14-000-72125	982.95
					Total :	982.95
196293	3/18/2022	012057 COMCAST CABLE	8771401810010702		ACCT#8771401810010702 16250 OF	
			8771401810028977		01-35-000-72517	10.51
			8771401810296319		ACCT#8771401810028977 7980 183	
					01-26-025-72517	52.55
				VTP-018413	ACCT# 8771401810296319 PUBLIC	
					01-14-000-72125	479.70
					Total :	542.76
196294	3/18/2022	018311 CONNECTION	72536580		IPHONE CHARGER KIT	
					01-16-000-74128	102.52
					Total :	102.52
196295	3/18/2022	003222 CONSOLIDATED HIGH SD 230	030822		IMPACT FEES JUL'21 THROUGH FE	
					84-00-000-23125	1,300.00
					Total :	1,300.00
196296	3/18/2022	012826 CONSTELLATION NEWENERGY, INC.	61869146701		ACCT#875222 UTIL#3613125002 1/3	
			61869147001		64-00-000-72510	1,354.13
			61869147801		ACCT#875223 UTIL#3670129006 16	
					64-00-000-72510	439.68
					ACCT#875224 UTIL#3784068018 18	

vchlist
03/17/2022 4:30:36PM

Voucher List
Village of Tinley Park

Page: 7

Bank code : apbank

<u>Voucher</u>	<u>Date</u>	<u>Vendor</u>	<u>Invoice</u>	<u>PO #</u>	<u>Description/Account</u>	<u>Amount</u>
196296	3/18/2022	012826	CONSTELLATION NEWENERGY, INC.	(Continued)		
					60-00-000-72510	4,672.35
					63-00-000-72510	4,672.35
			61869155401		ACCT#875225 UTIL#4373166015 66	
					60-00-000-72510	2,811.71
					63-00-000-72510	2,811.72
			61869175501		ACCT#875227 UTIL#5095140029 17	
					64-00-000-72510	6,204.62
					Total :	22,966.56
196297	3/18/2022	010846	COOK COUNTY CLERK	031022	NOTARY COMMISSION FOR N.O'CC	
					01-13-000-72720	10.00
					Total :	10.00
196298	3/18/2022	004009	EAGLE UNIFORM CO INC	INV-6413	BLANKET PO FOR CLASS B UNIFOI	
				VTP-018597	01-19-000-73610	304.50
				INV-6591	BLANKET PO FOR CLASS B UNIFOI	
				VTP-018597	01-19-000-73610	335.00
				INV-6598	BOOTS FOR LORENDO	
				VTP-019029	01-19-020-73610	125.00
				INV-6603	BLANKET PO FOR CLASS B UNIFOI	
				VTP-018597	01-19-000-73610	350.00
				INV-6604	BLANKET PO FOR CLASS B UNIFOI	
				VTP-018597	01-19-000-73610	350.00
					Total :	1,464.50
196299	3/18/2022	019561	ENDLESS COMMUNICATIONS USA LLC	DG-1455	PUSH TO TALK LTE DATA RADIO SV	
					01-42-000-72550	45.76
					Total :	45.76
196300	3/18/2022	004019	EVON'S TROPHIES & AWARDS	021822	REFLECTIVES FOR JACKETS	
					01-21-000-73610	110.00
				022822	PLAN COMMISSION NAMEPLATE A.	
					01-33-000-72310	18.90
					Total :	128.90
196301	3/18/2022	015058	FLEETPRIDE	94331867	OTR BRAKE CHMBR,ASA CLEVIS K	

vchlist
03/17/2022 4:30:36PM

Voucher List
Village of Tinley Park

Page: 8

Bank code : apbank

<u>Voucher</u>	<u>Date</u>	<u>Vendor</u>	<u>Invoice</u>	<u>PO #</u>	<u>Description/Account</u>	<u>Amount</u>
196301	3/18/2022	015058 FLEETPRIDE	(Continued)		01-26-023-72540	287.88
					Total :	287.88
196302	3/18/2022	012941 FMP	50-3749332		OIL DRAIN PLUG WATER UNIT #140	
					60-00-000-72540	7.61
					63-00-000-72540	2.54
					64-00-000-72540	4.35
			52-506800		BRAKE ROTOR AND CERAMIC PAD	
					01-33-300-72540	-204.30
			52-507283		FVP BRAKE ROTOR POLICE STOC	
					01-17-205-72540	260.00
			52-507563		FVP BRAKE ROTOR, BRAKE LININC	
					01-17-205-72540	226.42
					Total :	296.62
196303	3/18/2022	020195 FOREST PRINTING COMPANY	110215		BUSINESS CARDS - SCHATKE	
					01-26-023-73110	29.00
					60-00-000-73110	9.14
					63-00-000-73110	1.02
					64-00-000-73110	4.34
					Total :	43.50
196304	3/18/2022	002877 G. W. BERKHEIMER CO., INC.	041055		FILTERS	
					01-26-025-72520	186.72
					Total :	186.72
196305	3/18/2022	016889 GALLAGHER MATERIALS INC.	23371		COLD PATCH	
				VTP-019006	01-26-023-73780	3,043.14
					Total :	3,043.14
196306	3/18/2022	019349 GARVEY'S OFFICE PRODUCTS	PINV2225939		PAPER, ASTROBRIGHT, 65#, NL	
					01-19-000-73110	105.96
			PINV2226710		BAG, TALL, KITCH, 13G, WH	
					01-19-000-73110	29.86
			PINV2226742		BAG, ZIPLOC STORAGE GALLON	
					01-19-000-73110	36.68

vchlist
03/17/2022 4:30:36PM

Voucher List
Village of Tinley Park

Page: 9

Bank code : apbank

<u>Voucher</u>	<u>Date</u>	<u>Vendor</u>	<u>Invoice</u>	<u>PO #</u>	<u>Description/Account</u>	<u>Amount</u>
196306	3/18/2022	019349	GARVEY'S OFFICE PRODUCTS (Continued) PINV2227312		PEN, VELOCITY, GEL, 24/PK, BK 01-19-000-73110	26.55
Total :						199.05
196307	3/18/2022	012872	GMIS ILLINOIS 2018469		GIANTS 2021 CONF 4/24-4/27/2022 01-16-000-72170	125.00
Total :						125.00
196308	3/18/2022	015397	GOVTEMPSUSA LLC 3843098		D.VANNORSDEL WEEK ENDING 10/ 30-00-000-74160	2,030.00
			3886605		D.VANNORSDEL WEEK ENDING 1/9 30-00-000-74160	1,820.00
			3895063		D.VANNORSDEL WEEK ENDING 1/1 30-00-000-74160	1,120.00
			3903558		D.VANNORSDEL WEEK ENDING 1/3 30-00-000-74160	2,450.00
			3920636		D.VANNORSDEL WEEK ENDING 3/6 30-00-000-74160	560.00
Total :						7,980.00
196309	3/18/2022	019784	HEARTLAND BUSINESS SYSTEMS LLC 501575-H	VTP-018913	OFFICE 365 CLOUD SETUP 01-16-000-72650	323.75
			501576-H	VTP-018913	OFFICE 365 CLOUD SETUP 01-16-000-72650	370.00
			501584-H	VTP-018917	PD LAPTOPS 30-00-000-74137	17,135.00
			502908-H	VTP-018917	PD LAPTOPS 30-00-000-74137	68,217.40
Total :						86,046.15
196310	3/18/2022	004741	HEARTS & FLOWERS 010190		SYMPATHY FLOWERS 01-26-023-73110	56.99
Total :						56.99
196311	3/18/2022	018696	HENRY'S HOUSE OF DECORATED 1024		UNIFORMS FOR PUBLIC WORKS E 01-26-023-73610	276.80

vchlist
03/17/2022 4:30:36PM

Voucher List
Village of Tinley Park

Page: 10

Bank code : apbank

<u>Voucher</u>	<u>Date</u>	<u>Vendor</u>	<u>Invoice</u>	<u>PO #</u>	<u>Description/Account</u>	<u>Amount</u>
196311	3/18/2022	018696 HENRY'S HOUSE OF DECORATED	(Continued)			
					60-00-000-73610	162.76
					63-00-000-73610	31.00
					64-00-000-73610	83.04
					01-26-024-73610	138.40
			1033		UNIFORMS FOR PUBLIC WORKS E	
					60-00-000-73610	130.98
					63-00-000-73610	24.95
					64-00-000-73610	66.83
					01-26-023-73610	78.49
					Total :	993.25
196312	3/18/2022	001487 HOMEWOOD DISPOSAL SERVICE	7759235		LINERS	
					01-26-023-73870	450.00
			7759236		LINERS	
					01-26-023-73870	450.00
					Total :	900.00
196313	3/18/2022	004955 ILCMA	3453		JOB POSTING - MANAGMENT ANAL	
					01-12-000-72446	50.00
					Total :	50.00
196314	3/18/2022	015497 ILLINOIS SECRETARY OF STATE	031522		2015 CHEVY EQUINOX IL1620141 2	
					01-17-205-72860	151.00
					Total :	151.00
196315	3/18/2022	005186 INTERSTATE BATTERY SYSTEM	10074928		M-65HC STREET#38 BATTERY	
					01-26-023-72540	107.00
					Total :	107.00
196316	3/18/2022	005251 J AND R SALES AND SERVICE INC.	0345697		CHAIN RAPID SUPER	
					01-26-023-73410	119.66
					Total :	119.66
196317	3/18/2022	011466 JEWEL OSCO	030422		****0414 SANDWICHES FOR IRISH I	
					01-21-000-72220	44.99
			031022		COFFEEMATE AND VENDING MACH	

vchlist
03/17/2022 4:30:36PM

Voucher List
Village of Tinley Park

Page: 11

Bank code : apbank

<u>Voucher</u>	<u>Date</u>	<u>Vendor</u>	<u>Invoice</u>	<u>PO #</u>	<u>Description/Account</u>	<u>Amount</u>
196317	3/18/2022	011466 JEWEL OSCO	(Continued)		01-26-024-73115	0.66
					01-26-023-73115	1.32
					60-00-000-73115	0.46
					63-00-000-73115	0.46
					64-00-000-73115	0.40
					01-14-000-73115	15.97
					Total :	64.26
196318	3/18/2022	013964 LAZZARA, ANGELO	031022		REIMB CPR CLASS	
					01-21-000-72140	15.00
					Total :	15.00
196319	3/18/2022	020207 LENNY'S GAS N WASH 183RD ST	2966		CAR WASH - VM	
					01-12-000-72540	8.00
					Total :	8.00
196320	3/18/2022	014402 LEXISNEXIS RISK DATA MNGMNT	1038013-20220228		FEB 2022 MIN COMMITMENT	
					01-17-225-72852	150.00
					Total :	150.00
196321	3/18/2022	020423 LUCKY LOCATORS INC	27340		LOCATE BREAK OF FIBER OPTIC C	
				VTP-019010	60-00-000-72790	367.50
				VTP-019010	01-26-025-72552	367.50
					Total :	735.00
196322	3/18/2022	015020 LYNN CARD COMPANY	2220221-009		SYMPATHY CARDS	
					01-19-000-72310	255.00
					Total :	255.00
196323	3/18/2022	019023 M & F SERVICES ONE INC	2419		TESTING AND CERT OF 3/4 WATTS	
					01-26-025-72790	440.00
					Total :	440.00
196324	3/18/2022	019379 MACQUEEN EMERGENCY GROUP	W01684		ENGINE 47 ENFORCER PUMPER	
					01-19-000-72540	316.36
					Total :	316.36

vchlist
03/17/2022 4:30:36PM

Voucher List
Village of Tinley Park

Page: 12

Bank code : apbank

<u>Voucher</u>	<u>Date</u>	<u>Vendor</u>	<u>Invoice</u>	<u>PO #</u>	<u>Description/Account</u>	<u>Amount</u>
196325	3/18/2022	013969	MAP AUTOMOTIVE OF CHICAGO		CORE CREDITS	
			40-582428		01-17-205-72540	-64.00
			40-606041	S	CORE CREDIT	
			40-620805		01-17-205-72540	-15.00
			40-654258		BATTERY RETURN DEFECT	
					01-17-205-72540	-115.08
			40-657514	S	CORE CREDIT	
					01-17-205-72540	-48.00
			40-657515		BATTERY PD 15A	
					01-17-205-72540	118.50
					BATTERY PD - 2C,26B,20B	
					01-17-205-72540	355.50
					Total :	231.92
196326	3/18/2022	020322	MASTER AUTO SUPPLY		RETURN WIPER LINK AND LINKAGE	
			15030-113474		01-26-023-72540	-20.02
			15030-115160		HEATER CONTROL VALVE	
					01-21-000-72540	27.80
					Total :	7.78
196327	3/18/2022	006074	MENARDS		GORILLA SPRAY ADHESIVE	
			18544		60-00-000-73870	13.26
					63-00-000-73870	13.26
					64-00-000-73870	11.36
					01-26-023-73870	37.88
					01-26-024-73870	18.94
			18567		AC2 GREEN TRTD	
					60-00-000-73870	11.74
					63-00-000-73870	11.74
					64-00-000-73870	10.07
					01-26-023-73870	33.55
					01-26-024-73870	16.78
			18570		2X4X6' CEDAR HANDRAIL	
					60-00-000-73870	19.49
					63-00-000-73870	19.49
					64-00-000-73870	16.70
					01-26-023-73870	55.68

vchlist
03/17/2022 4:30:36PM

Voucher List
Village of Tinley Park

Page: 13

Bank code : apbank

<u>Voucher</u>	<u>Date</u>	<u>Vendor</u>	<u>Invoice</u>	<u>PO #</u>	<u>Description/Account</u>	<u>Amount</u>
196327	3/18/2022	006074	MENARDS			
			(Continued)			
			18571		01-26-024-73870 HANDRAIL GREEN	27.84
					60-00-000-73870	10.07
					63-00-000-73870	10.07
					64-00-000-73870	8.63
					01-26-023-73870	28.78
					01-26-024-73870	14.41
			18596		FILTER,3IN SPREADER FOR TILE C	
					01-26-025-72520	22.26
			18598		IRISH PARADE MATERIALS - FURRI	
					01-35-000-72923	40.91
			18600		ALIEN TAPE, COLOR DUCK, TAPER	
					60-00-000-73870	11.63
					63-00-000-73870	11.63
					64-00-000-73870	9.96
					01-26-023-73870	33.22
					01-26-024-73870	16.61
			18605		RETURN AC2 GREEN TRTD,TREATI	
					01-26-024-73870	-2.20
					01-26-023-73870	-4.39
					60-00-000-73870	-1.54
					63-00-000-73870	-1.54
					64-00-000-73870	-1.31
			18607		TREATED HANDRAIL	
					01-26-024-73870	2.99
					01-26-023-73870	3.99
					60-00-000-73870	1.05
					63-00-000-73870	1.05
					64-00-000-73870	0.90
			18608		PERFORMAX 16' TAPE	
					60-00-000-73870	4.19
					63-00-000-73870	4.19
					64-00-000-73870	3.58
			18610		TEC WALL BASE ADHESIVE	
					01-26-025-72520	4.98
			18647		TEC WALL BASE ADHESIVE	

vchlist
03/17/2022 4:30:36PM

Voucher List
Village of Tinley Park

Page: 14

Bank code : apbank

<u>Voucher</u>	<u>Date</u>	<u>Vendor</u>	<u>Invoice</u>	<u>PO #</u>	<u>Description/Account</u>	<u>Amount</u>
196327	3/18/2022	006074	MENARDS		(Continued)	
			18681		01-26-025-72520 HEAVY DUTY STAPLES, BOSTITCH	9.94
			18696		01-26-023-73410 DISTILLED WATER GALLON, CAR C	8.08
					60-00-000-73110	12.59
					63-00-000-73110	1.40
					64-00-000-73110	6.00
					60-00-000-72540	0.47
					63-00-000-72540	0.16
					64-00-000-72540	0.27
					01-26-023-72540	0.90
					01-26-024-72540	0.44
			18697		TORX SCREWDRIVER	
					60-00-000-73410	0.55
					64-00-000-73410	0.47
					01-26-023-73410	1.58
					01-26-024-73410	0.80
					63-00-000-73410	0.55
			18699		2/0 STRAIGHT LINK, TOUCHNTONE	
					60-00-000-73870	10.36
					63-00-000-73870	10.36
					64-00-000-73870	8.88
					01-26-023-73870	29.60
					01-26-024-73870	14.79
			18850		100W A19 35K 11KHR LED4PK OPA	
					01-26-025-72520	14.99
			18852		27 GALLON TOTE	
					60-00-000-73110	10.57
					63-00-000-73110	1.17
					64-00-000-73110	5.03
					01-26-023-73110	16.78
					01-26-024-73110	8.39
			18872		GALV NIPPLES, GALV COUPLING	
					60-00-000-73630	62.90
					63-00-000-73630	6.99
					64-00-000-73630	29.95

vchlist
03/17/2022 4:30:36PM

Voucher List
Village of Tinley Park

Page: 15

Bank code : apbank

<u>Voucher</u>	<u>Date</u>	<u>Vendor</u>	<u>Invoice</u>	<u>PO #</u>	<u>Description/Account</u>	<u>Amount</u>
196327	3/18/2022	006074 MENARDS	(Continued) 18912		FEBREEZE, 30 GALLON TOTE 01-26-023-73870	17.64
			18924		01-35-000-73870 R13 KRAFT	13.99
			18994		64-00-000-72525 ALIEN TAPE, BAR HOLDER, 2 HOLE	49.98
			19007		64-00-000-72525 45 GALLON TOTE, LOC INSTANT MI	57.76
					60-00-000-73870	1.43
					63-00-000-73870	1.43
					64-00-000-73870	1.23
					01-35-000-72923	22.98
					01-26-023-73870	4.09
					01-26-024-73870	2.04
					Total :	999.43
196328	3/18/2022	012517 MERIDIAN IT INC	509565		CUSTOMER CHANGE REQUEST SE 01-16-000-72650	555.00
					Total :	555.00
196329	3/18/2022	020263 MOBILE WIRELESS LLC	4675		NET MOTION COMPLETE SUBSCRI 01-16-000-72655	1,457.25
					Total :	1,457.25
196330	3/18/2022	005664 MORTON SALT INC	5402544342		ROAD SALT FOR 2021/2022 SEASO 01-26-023-73810	17,508.40
				VTP-018790	70-00-000-73810	651.91
				VTP-018790	08-00-000-73810	465.65
					Total :	18,625.96
196331	3/18/2022	017651 MSC INDUSTRIAL SUPPLY CO.	5264547001		WHEEL WEIGH,DRILL BITS,FLAT W 01-26-024-72540	80.11
					01-26-023-72540	160.22
					60-00-000-72540	84.12
					63-00-000-72540	28.04
					64-00-000-72540	48.07

vchlist
03/17/2022 4:30:36PM

Voucher List
Village of Tinley Park

Page: 16

Bank code : apbank

<u>Voucher</u>	<u>Date</u>	<u>Vendor</u>	<u>Invoice</u>	<u>PO #</u>	<u>Description/Account</u>	<u>Amount</u>
196331	3/18/2022	017651	017651 MSC INDUSTRIAL SUPPLY CO.	(Continued)		Total : 400.56
196332	3/18/2022	015386	MUNICIPAL GIS PARTNERS, INC	6401	FEB'22 GIS STAFFING 01-16-000-72652 60-00-000-72652 63-00-000-72652 64-00-000-72652	5,777.54 3,639.85 404.43 1,733.26 Total : 11,555.08
196333	3/18/2022	010918	NATIONAL POWER RODDING CORP.	Ref001418949	UB Refund Cst #00486347 60-00-000-20599	97.89 Total : 97.89
196334	3/18/2022	020438	NATIONAL SOFTWASH	Ref001418950	UB Refund Cst #00508927 60-00-000-20599	483.47 Total : 483.47
196335	3/18/2022	006216	NORTH EAST MULTI-REG TRAINING	299824	USE OF FORCE WORKSHOP TPPD 01-17-220-72140	1,200.00 Total : 1,200.00
196336	3/18/2022	019225	NORTHERN ILLINOIS CRITICAL	031022	GROUP CRISIS INTERVENTION TR 01-17-220-72140	200.00 Total : 200.00
196337	3/18/2022	010135	ONSITE COMMUNICATIONS USA, INC	51734	MOTOROLA LEATHER CASE AND B 01-17-220-73610	330.00 Total : 330.00
196338	3/18/2022	018370	ON-TARGET SOLUTIONS GRP,INC	INV43260	VTP-019026 TARGET SOLUTIONS MEMBERSHIP 01-19-000-72145	15,563.36 Total : 15,563.36
196339	3/18/2022	006475	PARK ACE HARDWARE	67483/1 67515/1 67520/1	ACCT#891432 INV#67483/1 FASTEN 01-42-000-72540 ACCT#9404 INV#67515/1 EXCHANG 01-19-000-73540 ACCT#9404 INV#67520/1 GRND CO	8.23 39.98

vchlist
03/17/2022 4:30:36PM

Voucher List
Village of Tinley Park

Page: 17

Bank code : apbank

<u>Voucher</u>	<u>Date</u>	<u>Vendor</u>	<u>Invoice</u>	<u>PO #</u>	<u>Description/Account</u>	<u>Amount</u>
196339	3/18/2022	006475	PARK ACE HARDWARE	(Continued)		
					01-19-000-73870	16.99
				67522/1	ACCT#9404 INV#67522/1 PLUNGER	
					01-19-000-73580	11.99
				67539/1	ACCT#89143 INV#67539/1 HOSE FL	
					60-00-000-73410	11.08
					63-00-000-73410	1.23
					64-00-000-73410	5.28
					Total :	94.78
196340	3/18/2022	020298	PEERLESS NETWORK INC	503775	VILLAGE LANDLINE PHONE SERV :	
					01-19-000-72120	3,326.61
					60-00-000-72120	2,253.75
					63-00-000-72120	250.42
					64-00-000-72120	1,073.22
					01-17-205-72120	747.68
					01-14-000-72120	620.00
					01-11-000-72120	0.22
					01-12-000-72120	0.51
					01-17-205-72120	0.51
					01-19-000-72120	0.11
					01-26-023-72120	0.13
					01-26-024-72120	0.13
					01-33-000-72120	0.27
					60-00-000-72120	0.35
					01-12-000-72120	38.78
					01-14-000-72120	121.20
					01-15-000-72120	24.24
					01-17-205-72120	72.72
					01-19-000-72120	33.94
					01-19-020-72120	9.70
					01-26-023-72120	14.54
					01-26-024-72120	14.54
					01-33-000-72120	77.57
					01-35-000-72120	14.54
					01-42-000-72120	9.70
					60-00-000-72120	48.48

vchlist
03/17/2022 4:30:36PM

Voucher List
Village of Tinley Park

Page: 18

Bank code : apbank

<u>Voucher</u>	<u>Date</u>	<u>Vendor</u>	<u>Invoice</u>	<u>PO #</u>	<u>Description/Account</u>	<u>Amount</u>
196340	3/18/2022	020298 PEERLESS NETWORK INC	(Continued)		63-00-000-72120	4.85
					Total :	8,758.71
196341	3/18/2022	013587 PROSHRED SECURITY	990111401		96 GALLON BIN SHREDDING SVC - 01-14-000-72790	54.50
					Total :	54.50
196342	3/18/2022	018110 PROVEN BUSINESS PRODUCTS	888124		MONTHLY CONTRACT SVC AGREE 01-16-000-72650	306.66
					Total :	306.66
196343	3/18/2022	017584 RELADYNE	1389573-IN		AFL API CERTIFIED DEF DR 01-19-000-73540	266.98
					Total :	266.98
196344	3/18/2022	017975 REVIZE LLC	13239		WEBSITE AND CMS ANNUAL TECH 01-35-000-72653	5,900.00
					Total :	5,900.00
196345	3/18/2022	006974 RINGHOFER, WILLIAM	AP040122		WILLIAM RINGHOFER HEALTH INSI 01-17-205-72435	663.30
					Total :	663.30
196346	3/18/2022	013442 ROADS SAFE-TRAFFIC SYSTEMS, INC	147361		SAFETY CONES	
				VTP-018992	01-26-023-73845	1,520.00
				VTP-018992	01-26-024-73845	760.00
				VTP-018992	60-00-000-73845	957.60
				VTP-018992	63-00-000-73845	106.40
				VTP-018992	64-00-000-73845	456.00
					Total :	3,800.00
196347	3/18/2022	016334 RUSH TRUCK CENTERS	3026011116		WINTER 2 IN WIPER STREETS 01-26-023-72540	142.60
			3026043448		SHOE KIT RETURN 01-26-023-72540	-106.40
			3026874178		MOBILE SERVICE CALL UNIT 58 SE 01-26-023-72540	447.20
				VTP-019023		

vchlist
03/17/2022 4:30:36PM

Voucher List
Village of Tinley Park

Page: 19

Bank code : apbank

<u>Voucher</u>	<u>Date</u>	<u>Vendor</u>	<u>Invoice</u>	<u>PO #</u>	<u>Description/Account</u>	<u>Amount</u>
196347	3/18/2022	016334 RUSH TRUCK CENTERS	(Continued) 3026879479	VTP-019018	TRUCK PART - SNOW PLOW 01-26-023-72540	2,410.00
Total :						2,893.40
196348	3/18/2022	020436 SAG MORAINÉ NATIVE PLANT	022222		VTP ENVIRONMENTAL COMM PLAN 01-41-044-73870	568.63
Total :						568.63
196349	3/18/2022	007629 SAM'S CLUB DIRECT	030422.		WATER,COFFEE FOR EMA OPEN H 01-21-000-72988	45.74
			030922		CUTLERY,WATER,COFFEE,PLATES 01-17-205-73315	160.84
			031022		VENDING MACHINE SNACKS,WATE 01-26-024-73115	18.48
					01-26-024-73870	3.20
					01-26-023-73115	36.95
					01-26-023-73870	6.39
					60-00-000-73115	12.93
					63-00-000-73115	12.93
					64-00-000-73115	11.09
					63-00-000-73870	2.24
					64-00-000-73870	1.92
					01-26-025-73580	19.84
					01-14-000-73115	81.67
					60-00-000-73870	2.24
			031122		BANKERS BOX 60-00-000-73110	23.93
					63-00-000-73110	2.66
					64-00-000-73110	11.39
			031522		BANKERS BOXES 01-26-025-73110	21.98
Total :						476.42
196350	3/18/2022	007177 SAM'S TECH SUPPLY INC.	176782		TIRE REPAIRS 01-17-205-72540	58.90
					01-26-024-72540	23.78

vchlist
03/17/2022 4:30:36PM

Voucher List
Village of Tinley Park

Page: 20

Bank code : apbank

<u>Voucher</u>	<u>Date</u>	<u>Vendor</u>	<u>Invoice</u>	<u>PO #</u>	<u>Description/Account</u>	<u>Amount</u>
196350	3/18/2022	007177 SAM'S TECH SUPPLY INC.	(Continued)		01-26-023-72540	47.56
					60-00-000-72540	24.97
					63-00-000-72540	8.23
					64-00-000-72540	14.36
					Total :	177.80
196351	3/18/2022	007092 SAUNORIS	679053		TOP SOIL PER YARD	
					01-26-024-73680	120.00
					Total :	120.00
196352	3/18/2022	013043 SITE DESIGN GROUP, LTD.	7482PH2-54		LANDSCAPING MGT SVC 12/19/21-	
				VTP-018432	01-26-023-72847	3,567.50
			7482PH2-55		LANDSCAPING 1/23-2/19/22	
				VTP-018432	01-26-023-72847	4,200.00
			7698-75		STORMWATER AREA MAINTENANC	
				VTP-018309	65-00-000-72847	3,050.00
			7698-76		STORMWATER AREA MAINTENANC	
				VTP-018309	65-00-000-72847	2,027.50
			7946-54		MOWING 12/21-1/22/22	
				VTP-018308	01-26-023-72847	1,120.00
			7954AS02-01		ENTRY PLAZA AT SOUTHEAST COF	
				VTP-018941	16-00-000-75315	1,000.00
			8498-37		URBAN FORESTRY PROGRAM 12/1	
				VTP-018431	01-26-023-72847	4,302.50
			8498-38		URBAN FORESTRY PROGRAM 1/23	
				VTP-018431	01-26-023-72847	4,322.29
			8803-22		LANDSCAPE MAINTENANCE MGT 1	
				VTP-018323	01-26-023-72847	440.00
					Total :	24,029.79
196353	3/18/2022	013950 SSWWA MEMBERSHIP	031622		SSWWA MEMBERSHIP A.SCHATTK	
					01-26-023-72720	66.67
					60-00-000-72720	13.33
					Total :	80.00
196354	3/18/2022	007224 STANDARD EQUIPMENT COMPANY	P34555		GUTTER BROOMS FOR SWEEPER:	

vchlist
03/17/2022 4:30:36PM

Voucher List
Village of Tinley Park

Page: 21

Bank code : apbank

<u>Voucher</u>	<u>Date</u>	<u>Vendor</u>	<u>Invoice</u>	<u>PO #</u>	<u>Description/Account</u>	<u>Amount</u>
196354	3/18/2022	007224 STANDARD EQUIPMENT COMPANY	(Continued)	VTP-019022	01-26-023-72530	786.56
Total :						786.56
196355	3/18/2022	012628 STATE FARM INSURANCE	031422		CANCELLED PARTICIPATION FOR I 01-14-000-79099	50.00
Total :						50.00
196356	3/18/2022	015452 STEINER ELECTRIC COMPANY	S007092646.004		STL CON STRAP FOR PARADE 01-26-024-73870 01-26-023-73870 60-00-000-73870 63-00-000-73870 64-00-000-73870	13.34 26.68 9.34 9.34 8.01
Total :						66.71
196357	3/18/2022	007297 SUTTON FORD INC./FLEET SALES	548232		LOCKASY POLICE 1R 01-17-205-72540	56.16
			548284		SHAFT ASY POLICE 1T 01-17-205-72540	305.76
			548419		RESERVOIR WINDSHIELD POLICE 01-17-205-72540	44.80
			548480		KIT ACTUATING LEVER 01-19-020-72540	101.92
			548488		NUT WHEEL 01-19-020-72540	72.80
			548490	VTP-019025	MUFFLER ASY 01-17-205-72540	787.25
			548536	VTP-019025	TUBE ASY, GASKET, NUT 01-17-205-72540	282.36
			548539		MIRROR ASY PD 1T 01-17-205-72540	230.62
Total :						1,881.67
196358	3/18/2022	018607 TELCOM INNOVATIONS GROUP, LLC	A58112		LABOR CHARGE FOR BILLABLE RE 01-26-025-72777	108.75

vchlist
03/17/2022 4:30:36PM

Voucher List
Village of Tinley Park

Page: 22

Bank code : apbank

<u>Voucher</u>	<u>Date</u>	<u>Vendor</u>	<u>Invoice</u>	<u>PO #</u>	<u>Description/Account</u>	<u>Amount</u>
196358	3/18/2022	018607	018607 TELCOM INNOVATIONS GROUP, LLC (Continued)			Total : 108.75
196359	3/18/2022	007717	THIRD DISTRICT FIRE CHIEF ASSN	4771	MONTHLY MAR'22 LUNCHEON KOR 01-19-000-72170	60.00 Total : 60.00
196360	3/18/2022	007930	TRANS UNION	02200293	CREDIT SUMMARY,EMPLOYMENT () 01-17-225-72852	90.00 Total : 90.00
196361	3/18/2022	013200	TRIBUNE PUBLISHING COMPANY	050010549000	CLASSIFIED LISTINGS 2/1-2/28/22 01-26-023-72330 01-33-310-72330	295.09 111.00 Total : 406.09
196362	3/18/2022	007909	TRI-RIVER POLICE TRAINING REG	5055	REID INTERVIEW & INTERROG 3/11 01-17-220-72140	150.00 Total : 150.00
196363	3/18/2022	004106	TYLER TECHNOLOGIES INC	045-371560	EXECUTIME MAINTENANCE 5/1/22- 01-15-000-72655	4,761.31 Total : 4,761.31
196364	3/18/2022	002613	UNITED HEALTHCARE AARP	AARP-AP040122	MARCH 22 PYMT FOR APRIL 22 CO 01-13-000-72435 60-00-000-72435 01-17-205-72435 60-00-000-72435 01-15-000-72435 01-26-024-72435 01-26-023-72435 60-00-000-72435 01-17-205-72435 01-26-025-72435 01-17-205-72435 60-00-000-72435	232.87 129.04 141.91 327.60 110.29 233.86 120.71 214.86 91.57 45.77 301.83 45.80
				AARP-PPAP040122	AARP POLICE PENSION MAR PMT// 01-17-205-72435	2,359.70

vchlist
03/17/2022 4:30:36PM

Voucher List
Village of Tinley Park

Page: 23

Bank code : apbank

<u>Voucher</u>	<u>Date</u>	<u>Vendor</u>	<u>Invoice</u>	<u>PO #</u>	<u>Description/Account</u>	<u>Amount</u>
196364	3/18/2022	002613 002613 UNITED HEALTHCARE AARP	(Continued)		Total :	4,355.81
196365	3/18/2022	018250 VERIZON CONNECT NWF INC	OSV000002699617		CUST ID TINL001 2/1-2/28/22 01-26-023-72790	275.23
					Total :	275.23
196366	3/18/2022	011416 VERIZON WIRELESS	9901041338		ACCT#242459316-00001 CENTRAL 60-00-000-72127 63-00-000-72127 64-00-000-72127	12.82 12.82 10.98
			9901768575		ACCT 280481333-00001 DATA 2/14-1 01-21-210-72127 01-26-023-72127 01-26-025-72127 11-00-000-72127 01-11-000-72127 01-12-000-72127 01-13-000-72127 01-15-000-72127 01-16-000-72127 01-17-220-72127 01-17-205-72127 01-19-000-72127 01-19-020-72127 01-33-000-72127 01-35-000-72127 60-00-000-72127 63-00-000-72127 64-00-000-72127	288.08 504.14 216.06 73.68 216.06 72.02 36.01 36.01 216.06 1,840.59 396.15 1,116.39 108.03 360.10 108.03 362.99 40.33 172.86
			9901768576		ACCT 2804813333-00003 MOBILE S 01-11-000-72120 01-12-000-72120 01-13-000-72120 01-14-000-72120 01-16-000-72120 01-17-205-72120 01-19-000-72120	307.01 105.48 126.45 12.70 370.84 4,494.66 181.57

vchlist
03/17/2022 4:30:36PM

Voucher List
Village of Tinley Park

Page: 24

Bank code : apbank

<u>Voucher</u>	<u>Date</u>	<u>Vendor</u>	<u>Invoice</u>	<u>PO #</u>	<u>Description/Account</u>	<u>Amount</u>
196366	3/18/2022	011416	VERIZON WIRELESS		(Continued)	
					01-19-020-72120	191.66
					01-21-000-72120	47.15
					01-21-210-72120	214.15
					01-26-023-72120	1,183.86
					01-26-024-72120	140.37
					01-35-000-72120	42.15
					60-00-000-72120	472.96
					63-00-000-72120	22.52
					64-00-000-72120	209.29
					01-26-025-72120	262.18
					01-33-000-72120	383.35
			9901769915		285837077-00001 TELLULAR SVC 2	
					01-17-205-72127	8.50
					Total :	14,977.06
196367	3/18/2022	010165	WAREHOUSE DIRECT WORKPL SOLTNS 5185231-0		A-Z FILE FOLDER,PENCILS	
					01-26-024-73110	1.95
					01-26-023-73110	3.90
					60-00-000-73110	12.23
					63-00-000-73110	1.36
					64-00-000-73110	5.84
			5188615-0		COPY PAPER	
					01-26-024-73110	28.64
					01-26-023-73110	57.28
					60-00-000-73110	36.09
					63-00-000-73110	4.01
					64-00-000-73110	17.17
			5191062-0		MONITOR STAND,SCISSORS,MOUSE	
					01-26-024-73110	28.17
					01-26-023-73110	56.34
					60-00-000-73110	35.49
					63-00-000-73110	3.94
					64-00-000-73110	16.90
					Total :	309.31
196368	3/18/2022	012322	WOOD, BRIAN	031422	REIMB PARKING TO ATTEND COUR	

vchlist
03/17/2022 4:30:36PM

Voucher List
Village of Tinley Park

Page: 25

Bank code : apbank

<u>Voucher</u>	<u>Date</u>	<u>Vendor</u>	<u>Invoice</u>	<u>PO #</u>	<u>Description/Account</u>	<u>Amount</u>
196368	3/18/2022	012322 WOOD, BRIAN	(Continued)		01-17-220-73600	48.99
Total :						48.99
94 Vouchers for bank code : apbank						Bank total : 372,497.42

vchlist
03/17/2022 4:30:36PM

Voucher List
Village of Tinley Park

Page: 26

Bank code : ipmq

<u>Voucher</u>	<u>Date</u>	<u>Vendor</u>	<u>Invoice</u>	<u>PO #</u>	<u>Description/Account</u>	<u>Amount</u>
3889	3/16/2022	018837	INSURANCE PROGRAM MANAGERS GR	210731W002	PAYEE-ALIGN NETWORKS INC 60-00-000-72542 63-00-000-72542 64-00-000-72542	228.87 43.59 116.78 Total : 389.24
3890	3/16/2022	018837	INSURANCE PROGRAM MANAGERS GR	210731W002-1	PAYEE-ALIGN NETWORKS INC 60-00-000-72542 63-00-000-72542 64-00-000-72542	198.90 37.89 101.47 Total : 338.26
3891	3/16/2022	018837	INSURANCE PROGRAM MANAGERS GR	210731W002-2	PAYEE-ALIGN NETWORKS INC 60-00-000-72542 63-00-000-72542 64-00-000-72542	228.87 43.59 116.78 Total : 389.24
3892	3/16/2022	018837	INSURANCE PROGRAM MANAGERS GR	210731W002-3	PAYEE-ALIGN NETWORKS INC 60-00-000-72542 63-00-000-72542 64-00-000-72542	198.90 37.89 101.47 Total : 338.26
3893	3/16/2022	018837	INSURANCE PROGRAM MANAGERS GR	200803W006	PAYEE-ENCOMPASS SPECIALTY NE 01-14-000-72542	158.73 Total : 158.73
3894	3/16/2022	018837	INSURANCE PROGRAM MANAGERS GR	200803W006-1	PAYEE-ENCOMPASS SPECIALTY NE 01-14-000-72542	151.03 Total : 151.03
3895	3/16/2022	018837	INSURANCE PROGRAM MANAGERS GR	200803W006-2	PAYEE-ENCOMPASS SPECIALTY NE 01-14-000-72542	151.03 Total : 151.03
3896	3/16/2022	018837	INSURANCE PROGRAM MANAGERS GR	200803W006-3	PAYEE-ENCOMPASS SPECIALTY NE 01-14-000-72542	151.03

vchlist
03/17/2022 4:30:36PM

Voucher List
Village of Tinley Park

Page: 27

Bank code : ipmq

Voucher	Date	Vendor	Invoice	PO #	Description/Account	Amount
3896	3/16/2022	018837	018837 INSURANCE PROGRAM MANAGERS (Continued)			Total : 151.03
3897	3/16/2022	018837	INSURANCE PROGRAM MANAGERS GR 200803W006-4		PAYEE-ENCOMPASS SPECIALTY NE 01-14-000-72542	151.03
					Total :	151.03
3898	3/16/2022	018837	INSURANCE PROGRAM MANAGERS GR 200803W006-5		PAYEE-ENCOMPASS SPECIALTY NE 01-14-000-72542	151.03
					Total :	151.03
3899	3/16/2022	018837	INSURANCE PROGRAM MANAGERS GR 200803W006-6		PAYEE-ENCOMPASS SPECIALTY NE 01-14-000-72542	151.03
					Total :	151.03
3900	3/16/2022	018837	INSURANCE PROGRAM MANAGERS GR 210731W002-4		PAYEE-ENCOMPASS SPECIALTY NE 60-00-000-72542 63-00-000-72542 64-00-000-72542	52.67 10.03 26.87
					Total :	89.57
3901	3/16/2022	018837	INSURANCE PROGRAM MANAGERS GR 200803W006-7		PAYEE-MCCA HILL CHIROPRACTIC 01-14-000-72542	226.24
					Total :	226.24
3902	3/16/2022	018837	INSURANCE PROGRAM MANAGERS GR 200211W025		PAYEE-PETERSON, JOHNSON & MI 01-14-000-72542	172.00
					Total :	172.00
3903	3/16/2022	018837	INSURANCE PROGRAM MANAGERS GR 210731W002-5		PAYEE-VILLAGE OF TINLEY PARK 60-00-000-72542 64-00-000-72542 63-00-000-72542	961.09 490.35 183.06
					Total :	1,634.50
15 Vouchers for bank code : ipmq						Bank total : 4,642.22
113 Vouchers in this report						Total vouchers : 385,437.12

vchlist
03/17/2022 4:30:36PM

Voucher List
Village of Tinley Park

Bank code : ipmq

Voucher	Date	Vendor	Invoice	PO #	Description/Account	Amount
---------	------	--------	---------	------	---------------------	--------

The Tinley Park Village Board having duly met at Village Hall do hereby certify that the following claims or demands against said village were presented and are approved for payment as presented on the above listing.

In witness thereof, the Village President and Clerk of the Village of Tinley Park, hereunto set their hands.

_____ Village President

_____ Village Clerk

_____ Date

vchlist
03/31/2022 3:57:28PM

Voucher List
Village of Tinley Park

Page: 1

Bank code : ap_py

<u>Voucher</u>	<u>Date</u>	<u>Vendor</u>	<u>Invoice</u>	<u>PO #</u>	<u>Description/Account</u>	<u>Amount</u>
126367	4/1/2022	017391 VSP ILLINOIS	PR040122		VSP 30061452 COBRA PMT-DEC&J/ 86-00-000-20430	23.36
Total :						23.36
1 Vouchers for bank code : ap_py						Bank total : 23.36

vchlist
03/31/2022 3:57:28PM

Voucher List
Village of Tinley Park

Page: 2

Bank code : apbank

<u>Voucher</u>	<u>Date</u>	<u>Vendor</u>	<u>Invoice</u>	<u>PO #</u>	<u>Description/Account</u>	<u>Amount</u>
196465	4/1/2022	015459 ABARAVICIUS, ALICE	032822		REFUND VEHICLE STICKER BOUGI 06-00-000-79005	45.00
					Total :	45.00
196466	4/1/2022	002628 AMERICAN WATER	4000231783		MAR'22 SEWER TREATMENT BROC 64-00-000-73225	455.67
					Total :	455.67
196467	4/1/2022	018807 BAXTER & WOODMAN INC	0232771		190816.60 LAGRANGE RD UTILITY 26-00-000-75707	5,228.78
					Total :	5,228.78
196468	4/1/2022	011713 CARR, PATRICK	032422		REIMB HOTEL,GAS FOR IML LOBBY 01-12-000-72130 01-12-000-72170	58.03 248.88
					Total :	306.91
196469	4/1/2022	015199 CHICAGO PARTS & SOUND LLC	2J0003538		INSTALL NEW TIMER IN UNIT 14A 01-17-205-72540	139.50
			3-0048937		PAD SET -FRT STREET#98 01-26-023-72540	46.32
			3-0048938		ACTUATOR - PD 5SAM 01-17-205-72540	24.55
			3-0048944		PRIME GUARD 5W30 12/10T 01-26-023-72540	33.48
					Total :	243.85
196470	4/1/2022	018325 CHICAGO TRIBUNE COMPANY LLC	197792300		SUBSCRIPTION THRU 6/23/22 01-17-205-72720	51.42
					Total :	51.42
196471	4/1/2022	003137 CHRISTOPHER B.BURKE ENGINEERNG	173140		01.R160373.00008 POST 5 LIFT STA 61-00-000-72840	2,142.50
			173141		01.R160373.00027 WATER RATE ST 60-00-000-72840	449.82
					63-00-000-72840	49.98
					64-00-000-72840	214.20

vchlist
03/31/2022 3:57:28PM

Voucher List
Village of Tinley Park

Page: 3

Bank code : apbank

<u>Voucher</u>	<u>Date</u>	<u>Vendor</u>	<u>Invoice</u>	<u>PO #</u>	<u>Description/Account</u>	<u>Amount</u>
196471	4/1/2022	003137 CHRISTOPHER B.BURKE ENGINEERNG	(Continued)			
			173142		01.R160373.00030 NEW WESTERN 26-00-000-75708	3,056.00
			173143		01.R160373.0003C LIGHTING PHAS 30-00-000-75500	322.00
			173144		01.R160373.00002 INTERIM ENG S\A 30-00-000-74604	202.50
			173145		64-00-000-72840 01.R160373.00024 WATER MODEL I 60-00-000-75813	4,312.99
					64-00-000-75813	375.20
					63-00-000-75813	321.60
			173146		01.R160373.D0025 DOROTHY LN W 26-00-000-75705	375.20
			173147		01.R160373.D0026 IRONWOOD DR 26-00-000-75704	5,205.95
			173148		01.R160373.D0029 NEW LAGRANGI 26-00-000-75708	3,540.95
			173149		SCHOOL FLASHING BEACON SIGN 30-00-000-73830	953.00
				VTP-018901		2,041.00
					Total :	23,562.89
196472	4/1/2022	013820 CINTAS CORPORATION	4114291420		MATS - PD 01-26-025-72790	111.81
			4114444218		MATS - VH 01-26-025-72790	210.33
					Total :	322.14
196473	4/1/2022	012315 CLASSY FLOWERS	100007712		SYMPATHY PLANT 01-14-000-73870	70.00
					Total :	70.00
196474	4/1/2022	012057 COMCAST CABLE	8771401810265348		ACCT#8771401810265348 6829 173 01-19-000-72517	97.11
			8771401810784702		ACCT#8771401810784702 7825 167 01-19-000-72517	90.78

vchlist
03/31/2022 3:57:28PM

Voucher List
Village of Tinley Park

Page: 4

Bank code : apbank

Voucher	Date	Vendor	Invoice	PO #	Description/Account	Amount
196474	4/1/2022	012057	012057 COMCAST CABLE		(Continued)	Total : 187.89
196475	4/1/2022	013892	COMED	6771163052	ACCT#6771163052 TRAFFIC SIGNA 01-26-024-72510	2,083.72
					Total :	2,083.72
196476	4/1/2022	013878	COMED - COMMONWEALTH EDISON	0021100130	ACCT#0021100130 17529 66TH AVE 01-26-024-72510	40.96
				0052035006	ACCT#0052035006 6720 SOUTH ST 01-26-025-72510	1,471.29
				0369095018	ACCT#0369095018 6761 NORTH ST 01-26-024-72510	450.74
				0519019106	ACCT#0519019106 6750 SOUTH ST 12-00-000-72510	18.63
				0522112018	ACCT#0522112018 17048 OPA 2/22- 01-26-024-72510	23.76
				1222218001	ACCT#1222218001 1 E OAK PK SOL 70-00-000-72510	82.43
				1224165129	ACCT#1224165129 7053 W 183RD S 01-26-024-72510	81.77
				2587063010	ACCT#2587063010 17311 OAK PARI 12-00-000-72510	19.33
				3784064010	ACCT#3784064010 16301 CENTRAL 60-00-000-72510	140.74
				4329016037	63-00-000-72510 ACCT#4329016037 17238 OAK PAR 12-00-000-72510	23.76
				4803158058	ACCT#4803158058 RIDGEFIELD LN 64-00-000-72510	201.39
				5437131000	ACCT#5437131000 7980 W 183RD S 01-26-025-72510	347.17
				7090006006	ACCT#7090006006 17231 OAK PAR 12-00-000-72510	10.33
				7398024011	ACCT#7398024011 7000 W 183RD S 01-26-024-72510	61.82
					Total :	3,114.85

vchlist
03/31/2022 3:57:28PM

Voucher List
Village of Tinley Park

Page: 5

Bank code : apbank

<u>Voucher</u>	<u>Date</u>	<u>Vendor</u>	<u>Invoice</u>	<u>PO #</u>	<u>Description/Account</u>	<u>Amount</u>
196477	4/1/2022	019406	CORDOGAN CLARK AND ASSOCIATES	23159	20-320 CCCS PUBLIC SAFETY BUIL 30-00-000-75112	37,486.25
				VTP-019040		Total : 37,486.25
196478	4/1/2022	003635	CROSSMARK PRINTING, INC	86114	BUSINESS CARDS D.REDA 01-19-000-72310	36.65
						Total : 36.65
196479	4/1/2022	018456	DEL GALDO LAW GROUP, LLC	28205	LEGAL SVC 2/1-2/28/22 18-00-000-72850	508.75
						Total : 508.75
196480	4/1/2022	003834	DRIVERS LICENSE GUIDE COMPANY	794551	2022 ID CHECKING GUIDE 01-17-225-73590	129.00
						Total : 129.00
196481	4/1/2022	004087	EMERGENCY MEDICAL PRODUCTS INC	2327060	NASOPHARYNGEAL AIRWAY,INFRA 01-19-000-73115	79.96
						Total : 79.96
196482	4/1/2022	004019	EVON'S TROPHIES & AWARDS	032322	BUSINESS BREAKFAST - BUSINES 01-41-045-72954	5,280.00
						Total : 5,280.00
196483	4/1/2022	004756	FIRST MIDWEST BANK 312	312-1843	SAFE DEPOSIT BOX RENTAL#312-1 01-17-205-73600	145.00
						Total : 145.00
196484	4/1/2022	012941	FMP	50-3785851	FVP WATER PUMP - STREETS UNIT 01-26-025-72530	72.83
				52-508533	BRAKE KIT PD STOCK 01-17-205-72540	82.65
				53-418172	FVP BRAKE ROTOR,BRAKE - PD ST 01-17-205-72540	214.65
				60-324212	FVP BRAKE ROTOR - PD STOCK 01-17-205-72540	132.00
						Total : 502.13

vchlist
03/31/2022 3:57:28PM

Voucher List
Village of Tinley Park

Page: 6

Bank code : apbank

<u>Voucher</u>	<u>Date</u>	<u>Vendor</u>	<u>Invoice</u>	<u>PO #</u>	<u>Description/Account</u>	<u>Amount</u>
196485	4/1/2022	020195 FOREST PRINTING COMPANY	110445		BUSINESS CARDS MITERA 01-33-000-72310	49.00
					Total :	49.00
196486	4/1/2022	011611 FOX VALLEY FIRE & SAFETY CO.	IN00508363		ANNUAL FIRE ALARM INSPECTION 01-26-025-72854	312.00
			IN00508365		ANNUAL FIRE ALARM INSPECTION 01-26-025-72854	170.00
			IN00508367		ANNUAL INSPECTION FIRE ALARM 01-26-025-72854	170.00
			IN00508369		ANNUAL INSPECTION FIRE ALARM 01-26-025-72854	170.00
					Total :	822.00
196487	4/1/2022	002877 G. W. BERKHEIMER CO., INC.	049115		PW HVAC FILTERS 01-26-025-72520	52.20
					Total :	52.20
196488	4/1/2022	018387 GBJ SALES, LLC	4292		SEWER DEGREASER 60-00-000-73550	112.42
					63-00-000-73550	112.42
					64-00-000-73550	96.36
					Total :	321.20
196489	4/1/2022	015397 GOVTEMPSUSA LLC	3929126		D.VANNORSDEL WEEK ENDING 3/1 30-00-000-74160	1,400.00
					Total :	1,400.00
196490	4/1/2022	004438 GRAINGER	9256123051		ATTACK LINE FIRE HOSE 01-26-023-73870	479.88
			9258220640		MARKING WAND 01-26-024-73410	7.04
					01-26-023-73410	14.08
					60-00-000-73410	8.87
					63-00-000-73410	0.99
					64-00-000-73410	4.23
					Total :	515.09

vchlist
03/31/2022 3:57:28PM

Voucher List
Village of Tinley Park

Page: 7

Bank code : apbank

Voucher	Date	Vendor	Invoice	PO #	Description/Account	Amount
196491	4/1/2022	020188 GRIFFIN WILLIAMS MCMAHON WALSH	11655		LABOR AND INVESTIGATION 12/1-2 01-14-000-72850	3,664.50
Total :						3,664.50
196492	4/1/2022	020454 HADDAD, KETAM & RAKAN	Ref001419397		UB Refund Cst #00462761, dupl pmt 60-00-000-20599	203.81
Total :						203.81
196493	4/1/2022	018696 HENRY'S HOUSE OF DECORATED	1074		PW CLERICAL STAFF UNIFORMS	
				VTP-019057	60-00-000-73610	84.67
				VTP-019057	63-00-000-73610	16.13
				VTP-019057	64-00-000-73610	43.20
				VTP-019057	60-00-000-73610	56.45
				VTP-019057	63-00-000-73610	10.75
				VTP-019057	64-00-000-73610	28.80
				VTP-019057	60-00-000-73610	381.01
				VTP-019057	64-00-000-73610	194.40
				VTP-019057	60-00-000-73610	254.01
				VTP-019057	63-00-000-73610	48.39
				VTP-019057	64-00-000-73610	129.60
				VTP-019057	60-00-000-73610	148.17
				VTP-019057	63-00-000-73610	28.23
				VTP-019057	64-00-000-73610	75.60
				VTP-019057	60-00-000-73610	19.70
				VTP-019057	63-00-000-73610	3.75
				VTP-019057	64-00-000-73610	10.05
				VTP-019057	63-00-000-73610	72.59
Total :						1,605.50
196494	4/1/2022	011032 HUB INTERNATIONAL MIDWEST LTD.	2653274		4 YEAR NOTARY BOND FOR A.HUM 01-17-205-72720	20.00
			2653285		4 YEAR NOTARY BOND FOR V.SED 01-17-205-72720	20.00
			2653292		4 YEAR NOTARY BOND FOR M.MCC 01-17-205-72720	20.00
			2653313		4 YEAR NOTARY BOND FOR L.FELL 01-17-205-72720	20.00

vchlist
03/31/2022 3:57:28PM

Voucher List
Village of Tinley Park

Page: 8

Bank code : apbank

Voucher	Date	Vendor	Invoice	PO #	Description/Account	Amount
196494	4/1/2022	011032 HUB INTERNATIONAL MIDWEST LTD.	(Continued) 2653324		4 YEAR NOTARY BOND FOR L.WIL/ 01-17-205-72720	20.00
			2653398		4 YEAR NOTARY BOND FOR K.SLIV 01-17-205-72720	20.00
			2653415		4 YEAR NOTARY BOND FOR J.SCHI 01-17-205-72720	20.00
			2653424		4 YEAR NOTARY BOND FOR M.MO1 01-17-205-72720	20.00
			2653431		4 YEAR NOTARY BOND FOR P.YUR 01-17-205-72720	20.00
			2653436		4 YEAR NOTARY BOND FOR P.ARD 01-17-205-72720	20.00
Total :						200.00
196495	4/1/2022	013910 IESMA	5914		MEMBERSHIP DUES P. CARR 1/1/21 01-21-000-72720	65.00
			6720		MEMBERSHIP DUES P.CARR 1/1/22 01-21-000-72720	65.00
			E2135		MEMBERSHIP L.KORTUM IESMA MI 01-21-000-72170	125.00
Total :						255.00
196496	4/1/2022	020452 IL SCHOOL COUNSELOR ASSOC	032422		CONVENTION CENTER INCENTIVE 12-00-000-72986	5,000.00
Total :						5,000.00
196497	4/1/2022	015497 ILLINOIS SECRETARY OF STATE	032522		NOTARY COMMISSION FILING V.SE 01-17-205-72720	10.00
			032522		NOTARY COMMISSION FILING P.YL 01-17-205-72720	10.00
			032522.		NOTARY COMMISSION FILING P.AF 01-17-205-72720	10.00
			032522..		NOTARY COMMISSION FILING L.WI 01-17-205-72720	10.00
			032522...		NOTARY COMMISSION FILING J.SC 01-17-205-72720	10.00

vchlist
03/31/2022 3:57:28PM

Voucher List
Village of Tinley Park

Page: 9

Bank code : apbank

Voucher	Date	Vendor	Invoice	PO #	Description/Account	Amount
196497	4/1/2022	015497 ILLINOIS SECRETARY OF STATE	(Continued) 032522....		NOTARY COMMISSION FILING K.SII 01-17-205-72720	10.00
			032522.....		NOTARY COMMISSION FILING M.M 01-17-205-72720	10.00
			032522.....		NOTARY COMMISSION FILING M.M 01-17-205-72720	10.00
			032522.....		NOTARY COMMISSION FILING A.HL 01-17-205-72720	10.00
			032522.....		NOTARY COMMISSION FILING L.FE 01-17-205-72720	10.00
					Total :	100.00
196498	4/1/2022	015288 KIESLER POLICE SUPPLY	IN186593	VTP-018675	FEDELE223T3~ 01-17-220-73760	995.00
					Total :	995.00
196499	4/1/2022	011822 LAPHEN, MORRIS	032822		REIMBURSEMENT CDL LICENSE 01-26-023-72860	61.35
					Total :	61.35
196500	4/1/2022	005222 LEE JENSEN SALES CO., INC.	0015103-00	VTP-019013 VTP-019013 VTP-019013	LOCATOR MACHINE 60-00-000-74017 63-00-000-74017 64-00-000-74017	193.90 193.90 166.20
					Total :	554.00
196501	4/1/2022	006559 LINDE GAS & EQUIPMENT INC	69611840		ACETYLENE 2/20-3/20/22 01-26-024-73730 01-26-023-73730 60-00-000-73730 63-00-000-73730 64-00-000-73730	58.06 116.12 40.65 40.65 34.83
					Total :	290.31
196502	4/1/2022	005537 LORENDO, STEVE	033022		REIMB HOTEL,MEAL FOR 2022 IL F 14-00-000-72140	358.69

vchlist
03/31/2022 3:57:28PM

Voucher List
Village of Tinley Park

Page: 10

Bank code : apbank

<u>Voucher</u>	<u>Date</u>	<u>Vendor</u>	<u>Invoice</u>	<u>PO #</u>	<u>Description/Account</u>	<u>Amount</u>
196502	4/1/2022	005537	005537 LORENDO, STEVE		(Continued)	Total : 358.69
196503	4/1/2022	003440	M. COOPER WINSUPPLY CO.		08674501 RESTROOM REPAIR KIT PARTS-VH 01-26-025-73630	145.83
					08674801 FAUCET - VH 01-26-025-73630	139.98
					Total :	285.81
196504	4/1/2022	013969	MAP AUTOMOTIVE OF CHICAGO		40-659356 CORE CHARGES CREDIT 01-17-205-72540	-48.00
					40-660028 BATTERY PD-28A,13B,45AM,10B 01-17-205-72540	474.00
					Total :	426.00
196505	4/1/2022	020322	MASTER AUTO SUPPLY		032222 BRAKE PADS,PAINTED ROTOR WA 60-00-000-72540	114.42
					63-00-000-72540	38.14
					64-00-000-72540	65.38
			15030-115557		SWIVEL,GREASE GUN -SHOP SUPI 01-26-024-73410	21.72
					01-26-023-73410	43.43
					60-00-000-73410	27.36
					63-00-000-73410	3.04
					64-00-000-73410	13.03
			15030-115598		HANGER PD #13A 01-17-205-72540	8.56
			15030-115706		MICRO V-BLT STREETS #90 01-26-023-72540	43.60
					Total :	378.68
196506	4/1/2022	015723	NICOR		90223493009 ACCT#90223493009 METER 508073 01-26-025-72511	499.68
					Total :	499.68
196507	4/1/2022	006216	NORTH EAST MULTI-REG TRAINING		300544 USE OF FORCE WORKSHOP TPPD 01-17-220-72140	1,200.00
					Total :	1,200.00

vchlist
03/31/2022 3:57:28PM

Voucher List
Village of Tinley Park

Page: 11

Bank code : apbank

<u>Voucher</u>	<u>Date</u>	<u>Vendor</u>	<u>Invoice</u>	<u>PO #</u>	<u>Description/Account</u>	<u>Amount</u>
196508	4/1/2022	006475 PARK ACE HARDWARE	006780/3		ACCT#891432 INV#006780/3 FILIT K 01-26-023-73410	123.37
			067629/1		ACCT#89143 INV#067629/1 PICTUR 01-26-025-73840	3.99
			067648/1		ACCT#89143 INV#067648/1 LED BU 01-26-025-72520	9.59
			67590/1		01-26-025-73580 ACCT#9404 INV#67590/1 BATTERY, 01-19-000-73585	4.98
			67623/1		01-19-000-73870 01-19-000-73580 ACCT#891432 INV#67623/1 LANYAF 60-00-000-72520	156.08
					64-00-000-72520	24.98
					63-00-000-72520	889.17
					Total :	1,224.11
196509	4/1/2022	006780 POMP'S TIRE SERVICE, INC	310200909		(4) 11R22.5 FIRESTONE FD711 TIRE 01-26-023-73560	1,341.00
			310200910	VTP-019027	(4) 11R 22.5 FIRESTONE TIRES	
			410942176	VTP-019028	01-26-023-73560	1,346.00
				VTP-019062	(8) 215/55HR16 FIRESTONE TIRES 60-00-000-73560	612.72
				VTP-019062	63-00-000-73560	204.24
				VTP-019062	64-00-000-73560	350.12
					Total :	3,854.08
196510	4/1/2022	006507 POSTMASTER, U. S. POST OFFICE	032922		STAMPS FOR FIRE ALARM MAILING 14-00-000-72110	464.00
					Total :	464.00
196511	4/1/2022	006507 POSTMASTER, U. S. POST OFFICE	032922.		FIRE SUPRESSION MAILINGS - 8 R 01-19-000-72110	464.00
					Total :	464.00
196512	4/1/2022	006507 POSTMASTER, U. S. POST OFFICE	032822		FIRE PREVENTION MAILINGS - 2 R 01-19-020-72110	116.00

vchlist
03/31/2022 3:57:28PM

Voucher List
Village of Tinley Park

Page: 12

Bank code : apbank

Voucher	Date	Vendor	Invoice	PO #	Description/Account	Amount
196512	4/1/2022	006507	006507 POSTMASTER, U. S. POST OFFICE (Continued)			Total : 116.00
196513	4/1/2022	006874	ROBINSON ENGINEERING CO. LTD.	22020422	19-R0866.01 TP 80TH AVE WATER M 26-00-000-75706	3,609.00
				22030195	11-320 TP THE BLVD AT CENTRAL S 27-00-000-72840	394.00
				22030338	19-R0866.01 TP 80TH AVE WATER M 26-00-000-75706	3,446.50
				22030388	21-R0005.014 TP FY2022 PMP RESI 05-00-000-72840	4,089.04
				22030389	21-R0945 TP RIVERWALK IMPROVE 18-00-000-72840	5,556.75
					Total :	17,095.29
196514	4/1/2022	007629	SAM'S CLUB DIRECT	032522	PACKAGING TAPE,PAPER TOWEL 01-26-025-73580	231.84
					01-26-023-73110	2.60
					01-26-024-73110	5.19
					60-00-000-73110	12.20
					63-00-000-73110	1.36
					64-00-000-73110	5.81
				032822	SODA,BATTERIES 01-26-024-73115	7.75
					01-26-024-73110	6.09
					01-26-023-73115	15.55
					01-26-023-73110	12.18
					60-00-000-73115	5.43
					63-00-000-73115	5.43
					64-00-000-73115	4.65
					60-00-000-73110	7.67
					63-00-000-73110	0.85
					64-00-000-73110	3.64
					Total :	328.24
196515	4/1/2022	018104	SBA STEEL,LLC	IN14062558	TOWER SITE RENT #IL46494-A-03 / 60-00-000-72631	201.02
					63-00-000-72631	201.02

vchlist
03/31/2022 3:57:28PM

Voucher List
Village of Tinley Park

Page: 13

Bank code : apbank

<u>Voucher</u>	<u>Date</u>	<u>Vendor</u>	<u>Invoice</u>	<u>PO #</u>	<u>Description/Account</u>	<u>Amount</u>
196515	4/1/2022	018104 SBA STEEL,LLC	(Continued)		64-00-000-72631	201.02
					01-17-205-72631	402.03
					01-19-000-72631	335.01
					Total :	1,340.10
196516	4/1/2022	007442 SEECO CONSULTANTS, INC	18827		CONSULTING STRUCTURAL SVC O	
					01-33-300-72840	1,740.00
					Total :	1,740.00
196517	4/1/2022	007350 SOUTH SUB. MAYORS & MANAGERS	2022-150		VENDOR FAIR MEMBER APPRECIATION	
					01-11-000-72220	500.00
					Total :	500.00
196518	4/1/2022	011767 STALEY, JENNIFER	033022		REIMBURSE 911 DISPATCH WASTE	
					01-21-210-72974	66.80
					Total :	66.80
196519	4/1/2022	007224 STANDARD EQUIPMENT COMPANY	P34857		GASKET	
			P34858		01-26-024-72540	133.14
			P34942		FUEL TUBE	
					01-26-023-72540	72.64
					GASKET STREET SWEEPER #10	
					01-26-023-72540	7.95
					Total :	213.73
196520	4/1/2022	012238 STAPLES BUSINESS ADVANTAGE	3502010637		TAPE,BOTTLE MOISTENER,PENS,F	
			3502010638		01-17-205-73110	118.15
			350201636		POST IT FLAGS	
					01-17-205-73110	12.21
			3502966316		CHAIR MAT,HANGING FOLDERS	
					01-14-000-73110	39.77
			3502966317		HEAVY DUTY CHISEL,SHARPIE,BO	
					01-14-000-73110	50.15
			3502966317		STORAGE BOXES,STAPLES	
					01-17-205-73110	135.83
			3502966318		TONERS	

vchlist
03/31/2022 3:57:28PM

Voucher List
Village of Tinley Park

Page: 14

Bank code : apbank

<u>Voucher</u>	<u>Date</u>	<u>Vendor</u>	<u>Invoice</u>	<u>PO #</u>	<u>Description/Account</u>	<u>Amount</u>
196520	4/1/2022	012238 STAPLES BUSINESS ADVANTAGE	(Continued)		01-17-205-73110	246.95
					Total :	603.06
196521	4/1/2022	015452 STEINER ELECTRIC COMPANY	S007106717.001		CONNECTOR,LOCKNUT,THERMAL 01-26-025-72520	45.45
			S007108730.001		STAINLESS COMBO TOOL,LONG N	109.34
			S007109365.001		LOW VOLT MTG BRACKET 01-26-025-72520	16.38
					Total :	171.17
196522	4/1/2022	015994 STERNBERG LIGHTING, INC.	62774		ODYSSEY LIGHTING	
				VTP-018984	08-00-000-73870	2,580.00
				VTP-018984	01-26-024-73570	180.00
					Total :	2,760.00
196523	4/1/2022	007438 SUB TRAILER HITCH, INC.	13550		DUST CAP,SEALS 01-26-023-72530	48.95
					Total :	48.95
196524	4/1/2022	010139 SULLIVAN, KEITH	032922		REIMB TUITION ONLINE TRAINING 01-17-220-72140	300.00
					Total :	300.00
196525	4/1/2022	007297 SUTTON FORD INC./FLEET SALES	549435		MOTOR ASY PD #13A 01-17-205-72540	23.74
			549529		BRACKET ENGINE PD STOCK 01-17-205-72540	140.22
			549572		SOCKET ASY PD RF 01-17-205-72540	234.08
			549694		WIPER WATER #4 60-00-000-72540	11.41
					63-00-000-72540	3.80
					64-00-000-72540	6.52
			549789		CABLE ASY BATTERY PD 2SAM 01-17-205-72540	170.24

vchlist
03/31/2022 3:57:28PM

Voucher List
Village of Tinley Park

Page: 15

Bank code : apbank

<u>Voucher</u>	<u>Date</u>	<u>Vendor</u>	<u>Invoice</u>	<u>PO #</u>	<u>Description/Account</u>	<u>Amount</u>
196525	4/1/2022	007297	007297 SUTTON FORD INC./FLEET SALES (Continued)			Total : 590.01
196526	4/1/2022	017944	TARGET SOLUTIONS LEARNING LLC	INV43260	TARGET SOLUTIONS MEMBERSHIP	
				VTP-019026	01-19-000-72145	15,563.36
						Total : 15,563.36
196527	4/1/2022	019192	TINLEY PARK CONVENTION CENTER	DPF-BK0491350011	VTP BUSINESS'S BREAKFAST MEE	
					01-41-045-72220	4,210.80
						Total : 4,210.80
196528	4/1/2022	019712	TM TIRE CO INC	139980	(8) ST205/75 R15 TRAILER TIRES	
				VTP-019065	01-26-023-73560	703.00
						Total : 703.00
196529	4/1/2022	013200	TRIBUNE PUBLISHING COMPANY	045579413000	LEGAL NOTICE DR. HORTON INC -I	
					01-33-310-72330	487.09
						Total : 487.09
196530	4/1/2022	008040	UNDERGROUND PIPE & VALVE CO	053707-01	MAIN BREAK CLAMPS	
				VTP-019034	60-00-000-73630	112.77
				VTP-019034	63-00-000-73630	12.53
				VTP-019034	64-00-000-73630	53.70
				VTP-019034	60-00-000-73630	401.94
				VTP-019034	63-00-000-73630	44.66
				VTP-019034	64-00-000-73630	191.40
				VTP-019034	60-00-000-73630	427.14
				VTP-019034	63-00-000-73630	47.46
				VTP-019034	64-00-000-73630	203.40
			053850		HYDRANT PARTS	
				VTP-019058	60-00-000-73632	497.00
				VTP-019058	64-00-000-73632	213.00
			053918		4" SPOOL PIECE	
				VTP-019055	60-00-000-73630	371.70
				VTP-019055	63-00-000-73630	41.30
				VTP-019055	64-00-000-73630	177.00
				VTP-019055	60-00-000-73630	7.56
				VTP-019055	63-00-000-73630	0.84

vchlist
03/31/2022 3:57:28PM

Voucher List
Village of Tinley Park

Page: 16

Bank code : apbank

Voucher	Date	Vendor	Invoice	PO #	Description/Account	Amount
196530	4/1/2022	008040 UNDERGROUND PIPE & VALVE CO	(Continued)	VTP-019055	64-00-000-73630	3.60
Total :						2,807.00
196531	4/1/2022	011416 VERIZON WIRELESS	9902444079		ACCT#442345192-00001 WATER RE	
					60-00-000-72127	17.79
					63-00-000-72127	17.79
					64-00-000-72127	15.25
Total :						50.83
196532	4/1/2022	013263 WEST SIDE TRACTOR SALES	S018618		OIL,AIR FILTER ELEMENT FOR STR	
					01-26-023-72540	414.83
Total :						414.83
68 Vouchers for bank code : apbank						Bank total : 155,195.13

vchlist
03/31/2022 3:57:28PM

Voucher List
Village of Tinley Park

Page: 17

Bank code : ipmq

<u>Voucher</u>	<u>Date</u>	<u>Vendor</u>	<u>Invoice</u>	<u>PO #</u>	<u>Description/Account</u>	<u>Amount</u>
3914	3/29/2022	018837	INSURANCE PROGRAM MANAGERS GR	210526W019	PAYEE-ADVANCED PAIN CONSULTA 01-14-000-72542	41.47 Total : 41.47
3915	3/29/2022	018837	INSURANCE PROGRAM MANAGERS GR	200803W006	PAYEE-ENCOMPASS SPECIALTY NE 01-14-000-72542	90.47 Total : 90.47
3916	3/29/2022	018837	INSURANCE PROGRAM MANAGERS GR	200803W006-1	PAYEE-ENCOMPASS SPECIALTY NE 01-14-000-72542	204.69 Total : 204.69
3917	3/29/2022	018837	INSURANCE PROGRAM MANAGERS GR	200803W006-2	PAYEE-ENCOMPASS SPECIALTY NE 01-14-000-72542	409.38 Total : 409.38
3918	3/29/2022	018837	INSURANCE PROGRAM MANAGERS GR	210731W002	PAYEE-ENCOMPASS SPECIALTY NE 60-00-000-72542 63-00-000-72542 64-00-000-72542	78.07 14.87 39.84 Total : 132.78
3919	3/29/2022	018837	INSURANCE PROGRAM MANAGERS GR	210731W002-1	PAYEE-ENCOMPASS SPECIALTY NE 60-00-000-72542 63-00-000-72542 64-00-000-72542	287.46 54.75 146.66 Total : 488.87
3920	3/29/2022	018837	INSURANCE PROGRAM MANAGERS GR	210731W002-2	PAYEE-ENCOMPASS SPECIALTY NE 60-00-000-72542 63-00-000-72542 64-00-000-72542	52.67 10.03 26.87 Total : 89.57
3921	3/29/2022	018837	INSURANCE PROGRAM MANAGERS GR	200803W006-3	PAYEE-MIDWEST ORTHOPEDICS 01-14-000-72542	143.48 Total : 143.48

vchlist
03/31/2022 3:57:28PM

Voucher List
Village of Tinley Park

Page: 18

Bank code : ipmq

<u>Voucher</u>	<u>Date</u>	<u>Vendor</u>	<u>Invoice</u>	<u>PO #</u>	<u>Description/Account</u>	<u>Amount</u>
3922	3/29/2022	018837	INSURANCE PROGRAM MANAGERS GR	201119W024	PAYEE-PARKVIEW ORTHOPAEDIC (
					01-14-000-72542	2,224.34
					Total :	2,224.34
3923	3/29/2022	018837	INSURANCE PROGRAM MANAGERS GR	201119W024-1	PAYEE-PARKVIEW ORTHOPAEDIC (
					01-14-000-72542	2,297.82
					Total :	2,297.82
3924	3/29/2022	018837	INSURANCE PROGRAM MANAGERS GR	201119W024-2	PAYEE-PARKVIEW ORTHOPAEDIC (
					01-14-000-72542	270.88
					Total :	270.88
3925	3/29/2022	018837	INSURANCE PROGRAM MANAGERS GR	201119W024-3	PAYEE-PARKVIEW ORTHOPAEDIC (
					01-14-000-72542	240.78
					Total :	240.78
3926	3/29/2022	018837	INSURANCE PROGRAM MANAGERS GR	201119W024-4	PAYEE-PARKVIEW ORTHOPAEDIC (
					01-14-000-72542	240.78
					Total :	240.78
3927	3/29/2022	018837	INSURANCE PROGRAM MANAGERS GR	201119W024-5	PAYEE-PARKVIEW ORTHOPAEDIC (
					01-14-000-72542	270.88
					Total :	270.88
3928	3/29/2022	018837	INSURANCE PROGRAM MANAGERS GR	201119W024-6	PAYEE-PARKVIEW ORTHOPAEDIC (
					01-14-000-72542	270.88
					Total :	270.88
3929	3/29/2022	018837	INSURANCE PROGRAM MANAGERS GR	201119W024-7	PAYEE-PARKVIEW ORTHOPAEDIC (
					01-14-000-72542	270.88
					Total :	270.88
3930	3/29/2022	018837	INSURANCE PROGRAM MANAGERS GR	201119W024-8	PAYEE-PARKVIEW ORTHOPAEDIC (
					01-14-000-72542	270.88
					Total :	270.88
3931	3/29/2022	018837	INSURANCE PROGRAM MANAGERS GR	201119W024-9	PAYEE-PARKVIEW ORTHOPAEDIC (
					01-14-000-72542	270.88

vchlist
03/31/2022 3:57:28PM

Voucher List
Village of Tinley Park

Page: 19

Bank code : ipmq

<u>Voucher</u>	<u>Date</u>	<u>Vendor</u>	<u>Invoice</u>	<u>PO #</u>	<u>Description/Account</u>	<u>Amount</u>
3931	3/29/2022	018837	018837 INSURANCE PROGRAM MANAGERS (Continued)			Total : 270.88
3932	3/29/2022	018837	INSURANCE PROGRAM MANAGERS GR 210902W013		PAYEE-PETERSON JOHNSON & ML 01-14-000-72542	537.50
						Total : 537.50
3933	3/29/2022	018837	INSURANCE PROGRAM MANAGERS GR 210902W013-1		PAYEE-PETERSON JOHNSON & ML 01-14-000-72542	666.50
						Total : 666.50
3934	3/29/2022	018837	INSURANCE PROGRAM MANAGERS GR 220112W046		PAYEE-PETERSON JOHNSON & ML 01-14-000-72542	516.00
						Total : 516.00
3935	3/29/2022	018837	INSURANCE PROGRAM MANAGERS GR 220112W046-1		PAYEE-PETERSON JOHNSON & ML 01-14-000-72542	5,872.37
						Total : 5,872.37
3936	3/29/2022	018837	INSURANCE PROGRAM MANAGERS GR 190514W019		PAYEE-PETERSON JOHNSON & ML 01-14-000-72542	580.50
						Total : 580.50
3937	3/29/2022	018837	INSURANCE PROGRAM MANAGERS GR 190514W019-1		PAYEE-PETERSON JOHNSON & ML 01-14-000-72542	215.00
						Total : 215.00
3938	3/29/2022	018837	INSURANCE PROGRAM MANAGERS GR 211022W021		PAYEE-PETERSON JOHNSON & ML 01-14-000-72542	107.50
						Total : 107.50
3939	3/29/2022	018837	INSURANCE PROGRAM MANAGERS GR 210731W002-3		PAYEE-VILLAGE OF TINLEY PARK 60-00-000-72542 63-00-000-72542 64-00-000-72542	961.09 183.06 490.35
						Total : 1,634.50
26 Vouchers for bank code : ipmq						Bank total : 18,359.58

vchlist
03/31/2022 3:57:28PM

Voucher List
Village of Tinley Park

Bank code : ipmq

Voucher	Date	Vendor	Invoice	PO #	Description/Account	Amount
95 Vouchers in this report						
Total vouchers :						173,578.07

The Tinley Park Village Board having duly met at Village Hall do hereby certify that the following claims or demands against said village were presented and are approved for payment as presented on the above listing.

In witness thereof, the Village President and Clerk of the Village of Tinley Park, hereunto set their hands.

_____ Village President

_____ Village Clerk

_____ Date

THE VILLAGE OF TINLEY PARK
Cook County, Illinois
Will County, Illinois

ORDINANCE
NO. 2022-O-023

**AN ORDINANCE APPROVING A PURCHASE AND SALE AGREEMENT BETWEEN
THE VILLAGE OF TINLEY PARK AND GSP DEVELOPMENT, LLC, FOR THE SALE
OF PROPERTY LOCATED AT 7551 191ST STREET IN TINLEY PARK, ILLINOIS**

MICHAEL W. GLOTZ, PRESIDENT
NANCY O'CONNER, VILLAGE CLERK

WILLIAM P. BRADY
WILLIAM A. BRENNAN
DIANE M. GALANTE
DENNIS P. MAHONEY
MICHAEL G. MUELLER
COLLEN M. SULLIVAN
Board of Trustees

Published in pamphlet form by authority of the President and Board of Trustees of the Village of Tinley Park
Peterson, Johnson, and Murray Chicago, LLC, Village Attorneys
200 W. Adams, Suite 2125 Chicago, IL 60606

VILLAGE OF TINLEY PARK
Cook County, Illinois
Will County, Illinois

ORDINANCE NO. 2022-O-023

AN ORDINANCE APPROVING A PURCHASE AND SALE AGREEMENT BETWEEN THE VILLAGE OF TINLEY PARK AND GSP DEVELOPMENT, LLC, FOR THE SALE OF PROPERTY LOCATED AT 7551 191ST STREET IN TINLEY PARK, ILLINOIS

WHEREAS, Section 6(a) of Article VII of the 1970 Constitution of the State of Illinois provides that any municipality which has a population of more than 25,000 is a home rule unit, and the Village of Tinley Park, Cook and Will Counties, Illinois, with a population in excess of 25,000 is, therefore, a home rule unit and, pursuant to the provisions of said Section 6(a) of Article VII, may exercise any power and perform any function pertaining to its government and affairs, including, but not limited to, the power to tax and to incur debt; and

WHEREAS, the President and Board of Trustees of the Village of Tinley Park, Cook and Will Counties, believe and hereby declare that it will be in the best interests of the Village and its residents to approve and authorize the execution of a Purchase and Sale Agreement for the sale of property located at 7551 191st Street, Tinley Park, Illinois, to the GSP Development, LLC, as buyer, in the amount of ONE MILLION SEVEN HUNDRED THOUSAND DOLLARS AND NO CENTS (\$1,700,000.00), substantially in the form attached hereto as Exhibit 1 (“Agreement of Purchase and Sale”); and

NOW, THEREFORE, BE IT ORDAINED BY THE VILLAGE PRESIDENT AND BOARD OF TRUSTEES OF THE VILLAGE OF TINLEY PARK, COOK AND WILL COUNTIES, ILLINOIS, IN THE EXERCISE OF ITS HOME RULE POWERS, AS FOLLOWS:

SECTION 1: The foregoing recitals shall be and are hereby incorporated as findings of fact as if said recitals were fully set forth herein.

SECTION 2: The President and the Board of Trustees hereby approve the Purchase and Sale Agreement for the sale of property located at 7551 191st Street, Tinley Park, Illinois by the Village of Tinley Park, as seller, to GSP Development, LLC, as buyer, in the amount of ONE MILLION SEVEN HUNDRED THOUSAND DOLLARS AND NO CENTS (\$1,700,000.00), substantially in the form attached hereto as Exhibit 1; and the Village President and/or the Village Manager are hereby authorized to execute said Purchase Agreement, subject to review and revisions as to form by the Village Attorney.

SECTION 3: Any policy, resolution, or ordinance of the Village of Tinley Park that conflicts with the provisions of this Ordinance shall be and is hereby repealed to the extent of such conflict.

SECTION 4: That this Ordinance shall be in full force and effect from and after its adoption and approval.

SECTION 5: The Village Clerk be and hereby is authorized and directed to publish this Ordinance in pamphlet form.

PASSED THIS 5th day of April, 2022.

AYES:

NAYS:

ABSENT:

APPROVED THIS 5th day of April, 2022.

VILLAGE PRESIDENT

ATTEST:

VILLAGE CLERK

STATE OF ILLINOIS)
COUNTY OF COOK) SS
COUNTY OF WILL)

CERTIFICATE

I, NANCY O’CONNER, Village Clerk of the Village of Tinley Park, Counties of Cook and Will and State of Illinois, DO HEREBY CERTIFY that the foregoing is a true and correct copy of Ordinance No. 2022-O-023, “AN ORDINANCE APPROVING A PURCHASE AND SALE AGREEMENT BETWEEN THE VILLAGE OF TINLEY PARK AND GSP DEVELOPMENT, LLC, FOR THE SALE OF PROPERTY LOCATED AT 7551 191ST STREET IN TINLEY PARK, ILLINOIS,” which was adopted by the President and Board of Trustees of the Village of Tinley Park on the 5th day of April, 2022.

IN WITNESS WHEREOF, I have hereunto set my hand and affixed the corporate seal of the Village of Tinley Park this 5th day of April, 2022.

VILLAGE CLERK

AGREEMENT OF PURCHASE AND SALE

THIS AGREEMENT OF PURCHASE AND SALE (the "Agreement") is made and entered into as of the Effective Date (as defined herein), by and between the Village of Tinley Park ("Seller" or "Village") and GSP Development LLC or its assignee or nominee ("Purchaser").

In consideration of the mutual promises, covenants and agreements hereinafter set forth and of other good and valuable consideration, the receipt and sufficiency of which are hereby acknowledged, Seller and Purchaser agree as follows:

ARTICLE 1 **Sale of Property**

1.1 **Sale of Property.** Seller hereby agrees to sell, assign and convey to Purchaser and Purchaser agrees to purchase from Seller, all of Seller's respective right, title and interest in and to, the following:

(a) **Real Property.** The vacant parcel of real estate comprising approximately 71.9 acres and located near the Southwest Corner of 191st and Harlem Avenue, and commonly known as 7551 191st Street, Tinley Park, Will County Illinois and legally described on Exhibit A attached hereto together with all rights, appurtenances and privileges pertaining to such real estate, including, without limitation, all of Seller's right, title and interest, if any, in and to all easements, licenses, covenants and other rights-of-way or other appurtenances used in connection with the beneficial use and enjoyment of the real estate Land and the Improvements (collectively referred to herein as the "Real Property"). The Seller and Purchaser agree to amend Exhibit A, if necessary, with an updated legal description, PIN number, and common address of the Property, prior to the expiration of the Inspection Period as set forth in Section 4.1 of this Agreement.

(b) **Intangible Property.** All Seller's interest, if any, guarantees, licenses, approvals, certificates, plans and specifications, permits and warranties relating to the Property (collectively, the "Intangible Property").

The Real Property and the Intangible Property are sometimes collectively hereinafter referred to as the "Property".

ARTICLE 2 **Purchase Price**

2.1 **Purchase Price.** The purchase price to be paid to Seller for the Property is One Million Seven Hundred Thousand and no/100 Dollars (\$1,700,000) (the "Purchase Price"). The Purchase Price, as adjusted by all prorations as provided for herein, shall be paid to Seller by Purchaser at Closing, (as herein defined), by wire transfer of immediately available federal funds.

ARTICLE 3 **Deposit**

3.1 **Deposit.** Within five (5) business days after the Effective Date of this Agreement, the Purchaser shall pay Fifty Thousand and no/100 Dollars (\$50,000.00) ("Initial Deposit"). The Initial Deposit shall be

deposited with Chicago Title Insurance Company, 10 South LaSalle Street, Suite 3100, Chicago, Illinois 60603, ("Escrow Agent"), in a joint order escrow pursuant to the Escrow Agent's standard form of joint order escrow agreement (the "Escrow"). Within five (5) business days after approval of this Agreement by the Village as required in Section 9.2, Purchaser shall deposit with the Escrow Agent the additional sum of Fifty Thousand Dollars (\$50,000) ("Additional Deposit"). The Initial Deposit and the Additional Deposit shall be collectively referred to as the "Deposit". The cost of the Escrow shall be the Responsibility of Purchaser.

3.2 **Application Upon Default.** If the Closing occurs, the Deposit shall be credited against the Purchase Price at Closing. If the Closing does not occur in accordance with the terms hereof, the Deposit shall be held and delivered as hereinafter provided.

ARTICLE 4

Purchaser's Right of Inspection; Inspection Period

4.1 **Right to Evaluate.** Purchaser shall until June 1, 2022 (the "Inspection Period"), at Purchaser's sole cost and expense, to perform such inspections of the Property, status of zoning and required governmental approvals and such other analyses, inquiries and investigations as Purchaser shall deem necessary or appropriate (collectively "Due Diligence Investigation"). In the event Purchaser desires to conduct any such physical testing, drilling, boring, sampling or removal of, on or through the surface of the Property (or any part or portion thereof) (collectively, "Physical Testing"), the Purchaser shall submit to Seller, for Seller's approval, which shall not be unreasonably withheld conditioned or delayed, a written description of the scope and extent of the proposed Physical Testing. Any such tests, examinations or inspections of the Property by Purchaser and all costs and expenses in connection with Purchaser's inspection of the Property shall be at the sole cost of Purchaser. Purchaser shall remove or bond any lien which attaches to the Property by virtue of any of Purchaser's inspections After making such Physical Testing, Purchaser agrees to promptly restore the Property to its condition prior to such tests and inspections. Prior to Purchaser entering the Property to conduct the inspections and Physical Testing described above, Purchaser shall cause its contractors performing such work to obtain and maintain, and, upon request of Seller, shall deliver to Seller evidence of, the following insurance coverage: general liability insurance, from an insurer reasonably acceptable to Seller, in the amount of One Million and No/100 Dollars (\$1,000,000.00) combined single limit for personal injury and property damage per occurrence, such policy to name Seller and the Board of Education of Lincoln Way Community High School District 210 (the "School Board") as additional insured parties which insurance shall provide coverage against any claim for personal liability or property damage caused by such contractors in connection with such inspections and tests. Seller shall have the right, in its discretion, to accompany Purchaser and/or its agents during any inspection (including, but not limited to, Physical Testing) provided Seller or its agents do not unreasonably interfere with Purchaser's inspection. Purchaser agrees to indemnify and hold Seller and School Board, harmless from and against any and all claims, demands, suits, obligations, damages, losses, liabilities, costs and expenses, including but not limited to reasonable attorneys' fees, arising out of Purchaser or Purchaser's agents' inspections, tests and actions taken in or about the Property in the exercise of the inspection right granted herein. This obligation for indemnification shall survive the termination of this Agreement.

4.2 **Seller Deliveries.** Seller has delivered and made available to Purchaser all documents relating to the Property to the extent such items are in Seller's possession.

4.3 **Termination Right.** In the event that Purchaser is not satisfied with the Due Diligence Investigation for any reason, Purchaser may terminate this Agreement and provide written notice of such

termination to Seller prior to the end of the Inspection Period, and whereupon this Agreement shall terminate, the Deposit shall be delivered to Purchaser and neither party shall have any further rights or obligations to the other hereunder.

ARTICLE 5

Title and Survey Matters

5.1 **Title.** Promptly after the Effective Date, Purchaser shall order a title insurance commitment (the "Commitment") for an Owner's Policy of Title Insurance, issued by Chicago Title Insurance Company ("Title Company"), covering title to the Real Property in the initial amount of Ten Thousand and no/100 Dollars (\$10,000.00) and to be amended and increased at least fourteen (14) days prior to the Closing Date and committing to issue such Owner's Title Policy in the full amount of the Purchase Price. The Commitment shall include a 3.2 Zoning Endorsement with parking, contiguity, owner's comprehensive, access, utility facilities, and such other endorsements as determined by Purchaser after review of the Commitment and Survey. Purchaser shall notify Seller (the "Objection Notice") on or before the expiration of the Inspection Period, in writing (the "Title Objection Notice") of any title exceptions identified in the Commitment which it disapproves or which adversely affect the marketability of the Property (the "Title Objections"). No less than ten (10) days after being given the Title Objection Notice, Seller will use commercially reasonable efforts to cure and remove (or procure title insurance over to the extent reasonably satisfactory to Purchaser) such Title Objections. In the event Seller fails to modify and/or eliminate any such Exceptions within twenty-one (21) days after Purchaser's Objection Notice and Seller and Purchaser have not entered into a written agreement with regard to the modification or elimination of such Title Objections, Purchaser shall be entitled to: (i) terminate this Agreement, in which event the Deposit shall be refunded to Purchaser and neither party shall have any further liability to the other party under this Agreement, except as otherwise provided in this Agreement; or (ii) proceed to Closing and accept Title to the Property subject to such unacceptable Exceptions. All exceptions appearing in the Title Commitment to which Purchaser accepts are referred to as "Permitted Exceptions." Notwithstanding the foregoing, Seller shall be obligated to eliminate at or prior to Closing any: (a) financing liens, including mortgages, mechanic's and materialmen liens not caused by Purchaser, (b) tax liens relating to the Property, (c) liens or other Exceptions not resulting from acts of Purchaser occurring on or after the Effective Date, or (d) other liens or encumbrances which secure other monetary obligations of parties other than Purchaser.

5.2 **Survey.** Seller has provided to Purchaser a copy of an existing survey of the Property prepared by Geotech, Inc. and dated December 18, 2006. Promptly, and within twenty-one (21) days after the Effective Date, Purchaser, at its sole cost and expense, shall obtain a new survey dated after the date of this Agreement ("Survey"), which Survey conforms to the Minimum Standard Detailed Requirements for ALTA/NSPS Land Title Surveys as adopted in 2021 by ALTA/ NSPS, and including Table A Items 1, 2, 3, 4, 6, 7(a) (b) (1) (c), 8, 9, 11, 13, 14, 16, 17, 18 and 19, and in a form fully sufficient to cause the Title Company: (i) to delete the standard printed survey exceptions; and (ii) to issue the Title Policy free of any survey-related objections or exceptions whatsoever. The Survey shall be certified to the Seller, Purchaser and to the Title Company. If the Survey discloses any matters which are unacceptable to Purchaser or render title uninsurable or unmarketable, Purchaser shall notify Seller in writing (the "Survey Objection Notice") on or before expiration of the Inspection Period. No less than ten (10) days after being given the Survey Objection Notice, Seller shall notify Purchaser in writing of any disapproved Survey matters which Seller is unable or unwilling to cause to be removed or insured against prior to or at Closing and, with respect to such exceptions, Purchaser then shall elect, by giving written notice to Seller within three (3)

business days thereafter to either, (x) terminate this Agreement, or (y) waive its disapproval of such matters.

ARTICLE 6
Representations and Warranties of the Seller

6.1 **Seller's Representations.** Seller represents and warrants that the following matters are true and correct as of the Effective Date with respect to the Property and will be made again by Seller to Purchaser on and effective as of the Closing Date as follows:

(a) Subject to the Village Board's approval, as set forth and disclosed in Section 9.2 herein, and the Village's status as the Contract Purchaser of the Property as set forth and disclosed in Sections 8.1, 9.2, and 15.15 herein, Seller has the legal power, right and authority to enter into this Agreement, to consummate the transactions contemplated herein, and to execute and deliver all documents and instruments to be delivered by Seller hereunder. The individual(s) executing this Agreement on behalf of Seller have the legal power, right, and actual authority to bind Seller to the terms and conditions of this Agreement;

(b) Other than the Village's present contract to purchase and acquire title to the Property as set forth and disclosed in Sections 8.1, 9.2, and 15.15 herein, Seller is not a party to any contract, agreement or commitment to sell, convey, assign, transfer, provide rights of first refusal or other similar rights or otherwise dispose of any portion or portions of the Property;

(c) Seller has not received any written notice that the Property is in violation of any federal, state and local laws, ordinances, rules, regulations and orders;

(d) There are not presently pending, and Seller has received no written notice of, any special assessments of any nature with respect to the Property;

(f) The Property is presently exempt from the payment of real estate taxes; and

(e) To Seller's knowledge and without any obligation to investigate or inquire, the Property is not contaminated with any Hazardous Substances. For purposes of this Agreement, "*Hazardous Substances*" means any substance or material which gives rise to liability under any of the Environmental Laws. For purposes of this Agreement, "*Environmental Laws*" means the Resource Conservation and Recovery Act, 42 U.S.C. Section 6901 et seq., the Comprehensive Environmental Response, Compensation and Liability Act, 42 U.S.C. Sections 9601 et seq., the Clean Water Act, 33 U.S.C. Section 1251 et seq., and all other applicable state, county, municipal, administrative or other environmental, hazardous waste or substance, health and/or safety laws, ordinances, rules, and regulations pertaining to the environmental or ecological conditions on, under or about the Property.

PURCHASER ACKNOWLEDGES AND AGREES TO ACCEPT THE PROPERTY IN "AS IS" CONDITION AT THE TIME OF CLOSING, INCLUDING, WITHOUT LIMITATION, ANY DEFECTS OR ENVIRONMENTAL CONDITIONS, NOT OTHERWISE REMEDIATED BY THE SELLER PRIOR TO CLOSING, AFFECTING THE PROPERTY, WHETHER KNOWN OR UNKNOWN, WHETHER SUCH DEFECTS OR CONDITIONS WERE DISCOVERABLE THROUGH INSPECTION OR NOT. NO REPRESENTATIONS OR WARRANTIES HAVE BEEN MADE OR ARE MADE AND NO

RESPONSIBILITY HAS BEEN OR IS ASSUMED BY SELLER OR BY ANY OFFICER, EMPLOYEE, PERSON, FIRM, AGENT OR REPRESENTATIVE ACTING OR PURPORTING TO ACT ON BEHALF OF SELLER AS TO THE CONDITION OR REPAIR OF THE PROPERTY OR THE VALUE, EXPENSE OF OPERATION, OR INCOME POTENTIAL THEREOF OR AS TO ANY OTHER FACT OR CONDITION WHICH HAS OR MIGHT AFFECT THE PROPERTY OR THE CONDITION, REPAIR, VALUE, EXPENSE OF OPERATION OR INCOME POTENTIAL OF THE PROPERTY OR ANY PORTION THEREOF.

Seller hereby agrees to indemnify, defend and hold Purchaser harmless from and against any and all loss, damage, liability and expense (including reasonable attorneys' fees and other litigation expenses) which Purchaser may suffer, sustain or incur as a result of any misrepresentation or breach of warranty or agreement made by Seller for any document or instrument executed or to be executed by or on behalf of Seller pursuant to this Agreement and in furtherance of the transactions contemplated herein.

6.2 **Change in Representation/Waiver.** Seller shall deliver to Purchaser at Closing a statement certifying that the representations and warranties set forth above are true and correct in all material respects as of the Closing with the same effect as though made on the Closing.

6.3 **Survival.** The express representations and warranties of either Party to this Agreement shall survive the Closing for a period of six (6) months after the date of Closing.

ARTICLE 7 **Representations and Warranties of Purchaser**

7.1 Purchaser represents and warrants to Seller that the following matters are true and correct as of the Effective Date.

(a) This Agreement has been duly authorized and executed on behalf of Purchaser and constitutes the valid and binding agreement, enforceable in accordance with its terms. Purchaser has been duly formed, it is validly existing, and Purchaser has the full right and authority to enter into this Agreement, to complete the transactions contemplated hereby and to execute and deliver all documents and instruments to be delivered by Purchaser under this Agreement; and

(b) Purchaser is in compliance with the requirements of Executive Order No. 13224, 66 Fed. Reg. 49079 (Sept. 23, 2001) (the "Order") and other similar requirements contained in the rules and regulations of the office of Foreign Assets Control, Department of the Treasury ("OFAC") and in any enabling legislation or other Executive Orders or regulations in respect thereof.

Purchaser hereby agrees to indemnify, defend and hold Seller harmless from and against any and all loss, damage, liability and expense (including reasonable attorneys' fees and other litigation expenses) which Seller may suffer, sustain or incur as a result of any misrepresentation or breach of warranty or agreement made by Purchaser for any document or instrument executed or to be executed by or on behalf of Purchaser pursuant to this Agreement and in furtherance of the transactions contemplated herein.

ARTICLE 8
Seller's Interim Covenants

8.1 **Annexation and Zoning.** Seller is the contract purchaser of the Property and agrees to cooperate with the Purchaser during the Due Diligence Period and Post-Closing Approval Period (as defined in Section 15.17), to annex the Property into the Village at B3 zoning, and to re-zone any previously annexed and zoned parcels within the Property to B3 zoning. Purchaser acknowledges that the Village Board and Community Development staff have not been provided any concept or other preliminary plans for the development of this Property, and as such there is no guarantee that Village of Tinley Park will approve the zoning, re-zoning, entitlement, annexation, and future development plan for this Property.

8.2 **No Continuing Sale.** After the expiration of the Due Diligence Period and through the Closing Date and during the Post-Closing approval stage, Seller shall not list the Property for sale, solicit or evaluate any offers to purchase to purchase the Property, nor in any manner negotiate, discuss or enter into any agreement or option to sell or otherwise dispose of the Property or convey any interest in the Property to any third party, (hereinafter collectively referred to as "solicitation activities") unless and until this Agreement has been terminated in accordance with the terms hereof. However, nothing within this Section 8.2, shall be interpreted or construed to restrict or preclude the Village from exercising its Re-Purchase Option set forth in Section 15.17 herein, and subsequent thereto, perform any of the "solicitation activities" set forth above.

8.3 **Notices.** Seller will advise Purchaser promptly (no later than 7 days after notice or knowledge) of any notices, claims or any other matter or proceedings affecting the Property in any manner.

8.4 **New Agreements.** While this Agreement is in effect, Seller shall not, without the prior written consent of the Purchaser; do, suffer or permit, or agree to do, any of the following:

- A. enter into any easement, servitude, covenant, restriction, or right of way for or burdening the Property, or any part thereof;
- B. incur any liability or obligation or enter into any agreement, written or otherwise, with respect to the Property, or any part thereof, the term of which extends beyond the Closing Date, or which would obligate Purchaser to assume and pay the same, without Purchaser's prior written consent; or
- C. Sell, encumber or grant any interest in the Property, or any part thereof, in any form or manner whatsoever;

ARTICLE 9
Closing Conditions

9.1 **Conditions to Obligations of Purchaser.** The obligations of Purchaser under this Agreement to purchase the Property and consummate the other transactions contemplated hereby shall be subject to the satisfaction of the following conditions on or before the Closing Date, except to the extent that any of such conditions may be waived by Purchaser in writing at Closing.

(a) Upon recordation of the Deed and payment of the title insurance premium, the Title Company shall be prepared to issue to Purchaser an Owner's Policy of Title Insurance in the amount of the Purchase Price and subject only to the Permitted Exceptions.

(b) Delivery by Seller of possession of the Property shall be at Closing, subject to the Permitted Exceptions and not subject to any leases or contracts which survive Closing.

(c) After the Effective Date: (i) no change shall have occurred, without Purchaser's written consent, in the state of title matters disclosed in the Title Commitment and the Survey, and (ii) no material and adverse change shall have occurred in the Property or any of the other matters inspected by Purchaser.

(d) Seller shall have timely complied with its obligations hereunder.

(e) All warranties and representations made by Seller herein shall have been and remain truthful in all material respects and Seller's covenants have been duly performed.

The failure of any of the aforesaid conditions in any material respect shall entitle Purchaser, at its option, upon notice to Seller, to terminate this Agreement. In such event, this Agreement shall terminate, the Deposit shall be delivered to Purchaser and thereupon neither party shall have any further rights or obligations to the other hereunder.

9.2 Conditions to Obligations of Seller. The obligations of Seller under this Agreement to sell the Property is expressly conditioned on the following:

(a) Seller's Acquisition of Title to the Property. This Agreement is contingent on the Village closing on its contract to purchase the Property with the School Board and acquiring title to the same, on or before June 20, 2022.

(b) Approval of Village Board. This Agreement is contingent on the approval of the Village Board of the Village of Tinley Park, within 28 days after Purchaser's execution of this Agreement.

(c) Warranties, covenants and representations. All warranties and representations made by Seller herein shall have been and remain truthful in all material respects and Seller's covenants have been duly performed.

The non-performance and/or failure of any of the aforesaid conditions in any material respect, regardless of whether said performance or lack thereof was within the control of the Seller, shall entitle Seller, at its option, upon notice to Purchaser, to terminate this Agreement. In such event, this Agreement shall terminate, the Deposit shall be delivered to Purchaser and thereupon neither party shall have any further rights or obligations to the other hereunder.

ARTICLE 10

Closing, Prorations, Closing Costs and Credits

10.1 Closing. The closing of the purchase and sale of the Property shall occur on or before thirty (30) days following the expiration of the Due Diligence Period, and provided that all contingencies and

requirements to close this transaction have been satisfied. The Closing shall be held at the offices of the Title Company, or at such other place as agreed to by Seller and Purchaser. Closing shall be deemed to have occurred when the Title Company has been instructed by both Seller and Purchaser to record the deed, disburse the sale proceeds and issuance of the Title Policy. The sale shall be closed through escrow with the Title Company in accordance with the general provisions of the usual form of escrow agreement and the cost of the escrow shall be divided equally between Seller and Purchaser. The date of Closing is referred to in this Agreement as the "Closing" or the "Closing Date."

10.2 **Prorations.** All matters involving prorations or adjustments to be made in connection with Closing and not specifically provided for in some other provision of this Agreement shall be adjusted in accordance with this Section 10.2. Except as otherwise set forth herein, all items to be prorated pursuant to this Section 10.2 shall be prorated as of the Closing Date, with Seller to be treated as the owner of the Property, for purposes of prorations of income and expenses, through the Closing Date.

(a) **Prorations.** All items which are customarily prorated in transactions similar to this transaction, and which are not covered above will be prorated as of the Closing Date. If any proration or computations made under this Section are based on estimates and if prove to be incorrect, then either party shall be entitled to an adjustment, provided that it makes written demand on the party from whom it is entitled to an adjustment, within sixty (60) days after the Closing Date.

10.3 **Allocation of Closing Costs and Expenses.** Seller shall pay the cost to record any instruments or endorsements necessary to clear the Title Objections. Purchaser shall pay the cost of the title policy, any recording fees with respect to the deed, the cost of the Purchaser requested title endorsements and the cost of the Closing Escrow. The cost of state and transfer taxes, if any shall be paid by the Seller and municipal transfer taxes shall be allocated between Seller and Purchaser pursuant to local ordinance. In the event the Closing occurs, and after Purchaser has obtained all Post-Closing Approvals (as defined in Section 15.17), Purchaser shall also reimburse Seller for all of its closing, annexation, zoning and re-zoning costs, including but not limited to reasonable attorneys' fees (collectively "Seller Reimbursable Costs"), provided however in not event shall the Seller Reimbursable Costs exceed \$25,000

ARTICLE 11 **Closing Deliveries**

11.1 **Purchaser's Deliveries.** Purchaser or its assignee shall deliver or cause to be delivered to Seller or the Title Company at Closing the following:

- (a) The Purchase Price, plus or minus agreed upon prorations.
- (b) Executed original or counterpart of the Closing Escrow Disbursement Statement.
- (c) Such other documents as may be reasonably necessary or appropriate or required by the Title Company to effect the consummation of the transactions which are the subject of this Agreement.

11.2 **Seller's Deliveries.** Seller or its assignee shall deliver or cause to be delivered to Purchaser or the Title Company the following:

- (a) A special warranty deed (the "Deed") in recordable form properly executed by Seller conveying to Purchaser (or its nominee or assignee) good and marketable fee simple title to the Property, subject only to the Permitted Exceptions.
- (b) A General Assignment, duly executed by Seller, conveying and assigning to Purchaser the Intangible Property.
- (c) A certificate indicating that the representations and warranties set forth in Article 6 are true and correct on the Closing Date, or, if there have been changes, describing such changes.
- (d) A certificate certifying that Seller is not a "foreign person" as defined in Section 1445 of the Internal Revenue Code of 1986, as amended.
- (e) Applicable state, county and/or municipal transfer tax declarations signed by Seller.
- (f) Executed original or counterpart of the Closing Escrow Agreement and Disbursement Statement
- (g) Such other documents as may be reasonably necessary or appropriate to effect the consummation of the transactions which are the subject of this Agreement.

ARTICLE 12 **Risk of Loss**

12.1 **Condemnation.** If, prior to the Closing Date, all or any portion of the Property is taken by condemnation or eminent domain or is the subject of a pending taking which has not been consummated, Seller shall notify Purchaser of such fact promptly after Seller obtains knowledge thereof. Purchaser shall have the option to terminate this Agreement upon notice to Seller given not later than fifteen (15) days after receipt of Seller's notice, or the Closing Date, whichever is sooner. If this Agreement is terminated, the Deposit shall be returned to Purchaser and thereafter neither Seller nor Purchaser shall have any further rights or obligations to the other hereunder. If this Agreement is not terminated, (x) Seller shall assign, without recourse, and turn over to Purchaser all of the condemnation proceeds, net of any costs of repairs and net of reasonable collection costs (or, if such have not been awarded, all of its right, title and interest therein) payable with respect to such condemnation and (y) the parties shall proceed to Closing pursuant to the terms hereof without abatement of the Purchase Price.

ARTICLE 13 **Default**

13.1 **Default by Seller.** In the event the Closing and the transactions contemplated hereby do not occur as provided herein by reason of the default of Seller, Purchaser's may elect as its sole and exclusive

remedies to; (i) terminate this Agreement and receive the Deposit from the Escrow and in such event Seller shall not have any other liability whatsoever to Purchaser hereunder except for those obligations which expressly survive the termination of this Agreement or (ii) enforce specific performance of this Agreement and the obligations of Seller hereunder.

13.2 **Default by Purchaser.** In the event the Closing and the transactions contemplated hereby do not occur as provided herein by reason of any default of Purchaser, Seller's sole remedy shall be to terminate this Agreement and retain the Deposit as liquidated damages, and not as a penalty, it being understood that Seller's actual damages in the event of such a default are difficult to ascertain and that such Deposit Amount represents the parties' best estimate of such damages, and agreement in advance as to the settlement of any and all damages that may arise because of Purchaser's default, and bears a relation to the actual damages that might be sustained by Seller. Accordingly, the parties agree that the liquidated damage provision in this Section 13.2 is fair and reasonable, and it not a penalty as a result of non-performance. The remaining portion of the Deposit shall be paid to Purchaser and neither party shall have any further liability to the other, except for those obligations which expressly survive the termination of this Agreement.

ARTICLE 14

Brokers

14.1 **Brokers.** Purchaser and Seller each represents and warrants to the other that it has not dealt with any person or entity entitled to a brokerage commission, finder's fee or other compensation with respect to the transaction contemplated hereby. Purchaser hereby agrees to indemnify, defend, and hold Seller harmless from and against any claims or demands incurred by Seller by reason of any breach or inaccuracy of the Purchaser's (or its nominee's) representations and warranties contained in this Article 14. Seller hereby agrees to indemnify, defend, and hold Purchaser harmless from and against any claims or demands incurred by Purchaser by reason of any breach or inaccuracy of Seller's representations and warranties contained in this Article 14.

ARTICLE 15

Miscellaneous

15.1 **Notices.** Any and all notices, requests, demands or other communications hereunder shall be in writing and shall be deemed properly served (i) on the date sent if transmitted by personal delivery with receipt therefor, (ii) on the date sent if transmitted by facsimile or electronic mail (with confirmation by hard copy to follow by first class mail), (iii) on day after the notice is deposited with an overnight courier, or (iv) three (3) days after being sent by registered or certified mail, return receipt requested, first class postage prepaid, addressed as follows (or to such new address as the addressee of such a communication may have notified the sender thereof):

To Purchaser:

GSP Development LLC
 1111 E. Touhy – Suite 230
 Des Plaines, IL 60018
 Tel: 847-699-2152
 Fax: 847-699-2156
 Email: ldebb@gspdevelopment.com

With a copy to: Kenneth H. Brown.
Strauss Malk & Feder LLP
135 Revere Drive
Northbrook, IL 600
Tel 847-770-6909
Fax 847-770-6929
Email: kbrown@smflfp.com

To Seller: Village of Tinley Park
Patrick Carr
Village Manager
Village of Tinley Park
16250 Oak Park Avenue
Tinley Park, Illinois
pcarr@tinleypark.org
Tel: 708-475-8802
Fax: (708) 444-5099
Email: pcarr@tinleypark.org

With a copy to: Michael J. Pasquinelli, Jr.
Peterson, Johnson & Murray-Chicago
200 W. Adams Street-Suite 2125
Chicago, IL 60606
Tel: 312-724-8034
Fax: 312-896-9318
Email: mpasquinelli@pjmchicago.com

15.2 **Governing Law.** This Agreement shall be governed by and construed in accordance with the internal, substantive laws of the State of Illinois, without regard to the conflict of laws principles thereof.

15.3 **Headings.** The captions and headings herein are for convenience and reference only and in no way define or limit the scope or content of this Agreement or in any way affect its provisions.

15.4 **Effective Date.** This Agreement shall be effective upon delivery of this Agreement fully executed by the Seller and Purchaser, which date shall be deemed the Effective Date hereof. Either party may request that the other party promptly execute a memorandum specifying the Effective Date.

15.5 **Business Days.** If any date herein set forth for the performance of any obligations of Seller or Purchaser or for the delivery of any instrument or notice as herein provided should be on a Saturday, Sunday or legal holiday, the compliance with such obligations or delivery shall be deemed acceptable on the next business day following such Saturday, Sunday or legal holiday. As used herein, the term "legal holiday" means any state or Federal holiday for which financial institutions or post offices are generally closed in the state where the Property is located.

15.6 **Counterpart Copies.** This Agreement may be executed in two or more counterpart copies, all of which counterparts shall have the same force and effect as if all parties hereto had executed a single copy of this Agreement. Any facsimile signature of the parties on this Agreement transmitted by telecopier or

electronic mail shall be binding and effective as if an original and if requested of any party hereto, each of the parties agrees to re-execute original forms of any facsimile signature. No party hereto shall raise the use of a facsimile machine or other electronic transmission to deliver a signature or the fact that any signature was transmitted or communicated through the use of such electronic transmission as a defense to the formation or enforceability of this Agreement and each such party forever waives any such defense.

15.7 **Binding Effect.** This Agreement shall be binding upon, and inure to the benefit of, the parties hereto and their respective successors and assigns.

15.8 **Assignment.** Purchaser shall have the right to assign this Agreement with Seller's written consent, which consent shall not be unreasonably withheld, to an entity in which the principal of the Seller is either a controlling party or manager of the entity. Any other assignment to an unaffiliated third party shall be with Seller's prior written consent, which may be withheld or granted in Seller's sole exclusive discretion and if granted, is subject to the obligations as set forth in Section 15.16. Whenever reference is made in this Agreement to Seller or Purchaser, such reference shall include the successors and assigns of such party under this Agreement.

15.9 **Interpretation.** This Agreement shall not be construed more strictly against one party than against the other merely by virtue of the fact that it may have been prepared by counsel for one of the parties, it being recognized that both Seller and Purchaser have contributed substantially and materially to the preparation of this Agreement.

15.10 **Entire Agreement.** This Agreement and the Exhibits attached hereto contain the final and entire agreement between the parties hereto with respect to the sale and purchase of the Property and are intended to be an integration of all prior negotiations and understandings. Purchaser, Seller and their agents shall not be bound by any terms, conditions, statements, warranties or representations, oral or written, not contained herein. No change or modifications to this Agreement shall be valid unless the same is in writing and signed by the parties hereto. Each party reserves the right to waive any of the terms or conditions of this Agreement which are for their respective benefit and to consummate the transaction contemplated by this Agreement in accordance with the terms and conditions of this Agreement which have not been so waived. Any such waiver must be in writing signed by the party for whose benefit the provision is being waived.

15.11 **Severability.** If any one or more of the provisions hereof shall for any reason be held to be invalid, illegal or unenforceable in any respect, such invalidity, illegality or unenforceability shall not affect any other provision hereof, and this Agreement shall be construed as if such invalid, illegal or unenforceable provision had never been contained herein.

15.12 **Time.** Time is of the essence in the performance of each of the parties' respective obligations contained herein.

15.13 **Prevailing Party.** Should either party employ an attorney to enforce any of the provisions hereof, (whether before or after Closing, and including any claims or actions involving amounts held in escrow), the non-prevailing party in any final judgment agrees to pay the other party's reasonable expenses, expended or incurred in connection therewith, as determined by a court of competent jurisdiction. The provisions of this Section 15.13 shall survive Closing and/or any termination of this Agreement.

15.14 **1031 Exchange.** At the election of either Seller or Purchaser, such party may consummate the transaction contemplated by this Agreement as part of a tax deferred exchange of like kind property within

the meaning of Section 1031 of the Internal Revenue Code of 1986, as amended. In such event, the other party shall reasonably cooperate with the exchanging party to facilitate a like kind exchange of real property; provided, however (i) in no event shall the cooperating party be obligated to become personally liable under any contract, mortgage, installment note or other instrument not otherwise expressly required under this Agreement; and (ii) consummation of this transaction as a like kind exchange of real property shall not unreasonably delay the Closing.

15.15 **Condition Subsequent.** This Agreement is subject to the Seller completing the acquisition of the Property by no later than June 20, 2022 (“Seller Closing Condition”). In the event the Seller Closing Condition is not satisfied for any reason, then upon written notice to the Purchaser of the failure of the Seller Closing Condition, this Agreement shall terminate and neither party shall have any further liability to the other, except for those obligations which expressly survive the termination of this Agreement. Seller agrees to keep the Purchaser advised from time to time as to the status of the Seller Closing Condition, upon request of Purchaser.

15.16 **Post-Closing Development.** It is agreed and understood that Seller has agreed to sell the Property to Purchaser with the understanding that Purchaser or its permitted assigns, will be responsible for developing the Property as a retail strip shopping center (“Shopping Center”), and not for the purpose of re-selling the Property to a third party prior to the commencing construction of the Shopping Center. In the event within five (5) years after the Closing Date, Purchaser elects not to develop the Shopping Center, and sells the Property to an un-affiliated third party (“Third-Party Sale”), Purchaser agrees to pay to Seller 50% of the net profit received by Purchaser from the Third-Party Sale. The term “net profit” shall be the amount of net proceeds in excess of \$1,700,000 received by the Purchaser, and after deduction of all expenses of sale and prorations, including but not limited to title, survey, taxes, transfer fees, commission, closing escrow fees, and attorneys’ fees. Any amount due and owing to Seller shall be paid within 10 days after the Third-Party Sale closing. Upon the Purchaser’s commencement of the construction of the Shopping Center, this Section 15.16 shall be deemed null and void and Purchaser shall have no further liability hereunder. The phrase “construction of the Shopping Center” shall mean the physical construction of the shopping center building, and shall not be interpreted to include construction site development and improvement work, such as excavation, engineering, survey work, soil borings, environmental reports, utility work, sewer and water improvements, and the installation of streets, curb and gutter improvements. The above construction “commencement” provision shall not apply if Purchaser constructs the Shopping Center outside of the customary practice and sequence of site development and construction work.

15.17 **Post-Closing Annexation Entitlement Zoning.** In the event that Purchaser does not obtain approval to annex, zone, re-zone and/or entitle the Property and/or obtain a development agreement mutually agreeable to the Village and Purchaser, (collectively referred to as “Post-Closing Approvals), within one year after the Closing Date has occurred (the “Post-Closing Approval Period”), regardless of whether the inability to obtain the Post-Closing Approvals was within the control of the Seller, Purchaser or some other third-party. Seller shall repurchase from Purchaser and Purchaser shall sell to the Seller the Property at the price of \$1,700,000 (the “Re-Purchase Covenant”), regardless of whether the inability to obtain the Post-Closing Approvals was within the control of the Seller, Purchaser or some other third-party. The closing under the Re-Purchase Covenant shall occur within thirty (30) days after the expiration of the Post-Closing Approval Period. Independent of the Parties’ respective rights and obligations under the Re-Purchase Covenant, and provided that the Post-Closing Approvals have not been obtained, Seller shall independently have the sole, exclusive right and Option to re-purchase the Property, within one year after the Closing Date, at the price of \$1,700,000 (the “Seller’s Re-Purchase Option”), regardless of whether the inability to obtain the Post-Closing Approvals was within the control of the Seller, Purchaser

or some other third-party. The closing under the Re-Purchase Option, shall occur within 30-days of Seller's notice to the Property Owner that Seller intends to exercise the Option. Under both the Re-Purchase Covenant and Re-Purchase Option, Seller shall pay all costs and expenses attributable to the Purchaser's purchase and resale of the Property, including but not limited to title, escrow and closing fees, site investigation (including soil and environmental), design, engineering fees, and reasonable attorney's fees (collectively "Buy-Back Costs") provided however in no event shall the "Buy Back Costs" exceed \$50,000. The provisions of this Section 15.17 shall survive the Closing.

[SIGNATURE PAGE IMMEDIATELY FOLLOWS]

IN WITNESS WHEREOF, the parties hereto have executed this Agreement under seal on the date or dates set forth below.

PURCHASER:

GSP Development LLC

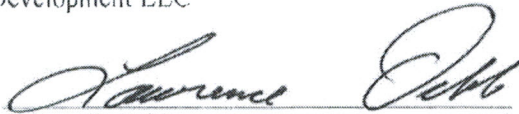
By: 
Lawrence Debb - manager

Date of Acceptance: 3-16, 2022.

SELLER:

Village of Tinley Park

By: _____

Date of Acceptance: _____, 2022.

Exhibit

Exhibit A - Legal Description

EXHIBIT A

LEGAL DESCRIPTION



Interoffice

Memo

Date: March 30, 2022

To: Pat Carr, Village Manager
John Urbanski, Public Works Director

From: Arlan Schattke, Village Engineer

Subject: Qualification Based Selection (QBS) Procedures

Presented for April 5, 2022 Village Board Agenda discussion and possible action:

Background:

Qualification Based Selection (QBS) ensures that federal agencies receive highly technical architect and engineering services from the most experienced and well qualified firms at a fair and reasonable cost. The QBS process is required by State and Federal law for certain public projects in Illinois.

Description:

The Village is required to adopt a QBS procedure and complete the process for Federally funded projects. Typically, the Village board has approved the QBS procedure on individual projects; However, adopting a standard Village QBS procedure provides consistency and expedites projects moving forward.

The policies and procedures meet all necessary requirements.

Budget / Finance:

There are no budget or financial implications to this resolution.

Staff Direction:

1. Adopt the attached QBS policy and procedures as the Village's standard.

Attachments:

1. Qualification Based Selection (QBS) Policy and Procedures March 2022.

THE VILLAGE OF TINLEY PARK
Cook County, Illinois
Will County, Illinois

RESOLUTION
NO. 2022-R-029

**A RESOLUTION APPROVING THE ADOPTION OF A
QUALIFICATIONS BASED SELECTION POLICY FOR ENGINEERING
AND PROFESSIONAL SERVICES**

MICHAEL W. GLOTZ, PRESIDENT
NANCY O'CONNER, VILLAGE CLERK

WILLIAM P. BRADY
WILLIAM A. BRENNAN
DIANE M. GALANTE
DENNIS P. MAHONEY
MICHAEL G. MUELLER
COLLEN M. SULLIVAN
Board of Trustees

Published in pamphlet form by authority of the President and Board of Trustees of the Village of Tinley Park
Peterson, Johnson, & Murray Chicago, LLC, Village Attorneys
200 W. Adams, Suite 2125, Chicago, IL 60606

VILLAGE OF TINLEY PARK

Cook County, Illinois

Will County, Illinois

RESOLUTION NO. 2022-R-029**A RESOLUTION APPROVING THE ADOPTION OF A
QUALIFICATIONS BASED SELECTION POLICY FOR ENGINEERING
AND PROFESSIONAL SERVICES**

WHEREAS, Section 6(a) of Article VII of the 1970 Constitution of the State of Illinois provides that any municipality which has a population of more than 25,000 is a home rule unit, and the Village of Tinley Park, Cook and Will Counties, Illinois, with a population in excess of 25,000 is, therefore, a home rule unit and, pursuant to the provisions of said Section 6(a) of Article VII, may exercise any power and perform any function pertaining to its government and affairs, including, but not limited to, the power to tax and to incur debt; and

WHEREAS, the Village of Tinley Park (“Village”) desires to adopt a qualified-based selection (“QBS”) process before retaining any engineering or professional services related to projects funded by the State of Illinois or any associated governmental entity; and

WHEREAS, the State of Illinois requires that municipalities utilize QBS procedures and policies in selecting consultants to oversee projects involving State funds; and

WHEREAS, the Village has established a written QBS Policy based on the requirements set forth by the State of Illinois, attached hereto as Exhibit 1; and

WHEREAS, the Corporate Authorities of the Village of Tinley Park, Cook and Will Counties, Illinois, have determined that it is in the best interest of said Village of Tinley Park and its residents to adopt said policy; and

NOW, THEREFORE, BE IT RESOLVED BY THE PRESIDENT AND BOARD OF TRUSTEES OF THE VILLAGE OF TINLEY PARK, COOK AND WILL COUNTIES, ILLINOIS, STATE AS FOLLOWS:

SECTION 1: The foregoing recitals shall be and are hereby incorporated as findings of fact as if said recitals were fully set forth herein.

SECTION 2: The President and Board of Trustees of the Village of Tinley Park hereby approve and adopt said QBS Policy substantially in the form, attached hereto as Exhibit 1, and made a part hereof.

SECTION 3: Any policy, resolution, or ordinance of the Village that conflicts with the provisions of this Resolution shall be and is hereby repealed to the extent of such conflict.

SECTION 4: That the Village Clerk is hereby ordered and directed to publish this Resolution in pamphlet form, and this Resolution shall be in full force and effect from and after its passage, approval, and publication as required by law.

PASSED THIS 5th day of April, 2022.

AYES:

NAYS:

ABSENT:

APPROVED THIS 5th day of April, 2022.

VILLAGE PRESIDENT

ATTEST:

VILLAGE CLERK

STATE OF ILLINOIS)
 COUNTY OF COOK) SS
 COUNTY OF WILL)

CERTIFICATE

I, NANCY M. O’CONNOR, Village Clerk of the Village of Tinley Park, Counties of Cook and Will and State of Illinois, DO HEREBY CERTIFY that the foregoing is a true and correct copy of Resolution No. 2022-R-029, **“A RESOLUTION APPROVING THE ADOPTION OF A QUALIFICATIONS BASED SELECTION POLICY FOR ENGINEERING AND PROFESSIONAL SERVICES,”** which was adopted by the President and Board of Trustees of the Village of Tinley Park on the 5th day of April, 2022.

IN WITNESS WHEREOF, I have hereunto set my hand and affixed the corporate seal of the Village of Tinley Park this 5th day of April, 2022.

VILLAGE CLERK



Village of Tinley Park, Illinois

Qualification Based Selection (QBS) Policy and Procedures

March 2022

When the Village of Tinley Park (VILLAGE) receives federal funds for consultant related engineering services, the VILLAGE consultant Quality Based Selection (QBS) process will comply with the following written policies and procedures, which meets the requirements of 23 CFR 172 and the Brooks Act. These policies and procedures, as adopted by the VILLAGE, substantially follow Section 5-5 of the Illinois Department of Transportation (IDOT) Bureau of Local Roads and Streets (BLRS) Manual, and specifically Section 5-5.06(e), and therefore separate approval from IDOT is not required.

I. Responsibility

The VILLAGE QBS policy and procedures assigns responsibility to the following personnel within the VILLAGE for the procurement of consultant engineering services, negotiations with the selected consultant engineering firm, and administration of the contract for projects utilizing federal funding, as described herein:

- **Village Clerk:** Posting of public notice for consultant engineering services in the form of a Request for Qualifications (RFQ) on the VILLAGE website; Placement of the RFQ in a local newspaper; Recipient of consultant submittals in response to the RFQ.
- **Village Engineer:** Point of contact for questions from potential respondents to the RFQ; Selection committee member; Lead negotiator with the selected consultant; Project Administrator (PA) after IDOT authorization to proceed.
- **Assistant Public Works Director:** Selection committee member; Assistant negotiator with the selected consultant.
- **Public Works Director:** Administrative oversight, selection committee member.
- **Village Board:** Approval of the selection committee results; Approval of the negotiated consultant contract for submittal to IDOT.

II. Public Notice

When developing the public notice for consultant engineering services, the VILLAGE will include the following information, with additional items as necessary when unique circumstances exist.

- Overall project description including the anticipated need, purpose, and objective of the project;
- The scope of engineering services being requested and any expected unique challenges;
- The desired timetable for the engineering services being requested;
- Identify any specific qualification requirements;
- Minimum submittal requirements from interested consultant engineering firms;
- Submittal instructions and due date;
- Evaluation criteria that will be used for reviewing and scoring the consultant submittals;
- Anticipated timeframe for the consultant selection;
- Instructions for retrieving available background information and submitting questions.



Village of Tinley Park, Illinois

Qualification Based Selection (QBS) Policy and Procedures

March 2022

The VILLAGE will post the public notice on the “Open Bids and Contracts” page of the VILLAGE website [<https://www.tinleypark.org>] and/or publish an ad in a newspaper with appropriate circulation. The public notice will be advertised for at least 14 days prior to the due date for consultant submittals with the website posting being continuous and the newspaper ad being at least twice.

The VILLAGE will require each responding consultant submit one (1) electronic copy and two (2) hard copies of their response to the RFQ for review by the selection committee. For consistency and to facilitate manageable review time, the VILLAGE will require that all submittals be single-sided and limited to a maximum of 20 pages, not including front and back covers, table of contents, and tabs.

III. Review of Consultant Submittals

Selection Committee: The VILLAGE will appoint a three (3) person selection committee for reviewing all consultant submittals. The selection committee members will include the Village Engineer, Assistant Director of Public Works and the Director of Public Works. The selection committee members must certify that they do not have a conflict of interest prior to completing their review of the consultant submittals, in compliance with the IDOT BLRS Manual, Section 5-5.04. If a replacement member of the selection committee is required, the replacement will be appointed by the Mayor.

Evaluation Factors: The Village Engineer will establish the evaluation factors for reviewing the consultant submittals for each project. The evaluation factors will typically include the criterion listed below, which complies with the weighting range guidance in Section 5-5.06(d) of the IDOT BLRS Manual.

- Project Understanding
- Similar Project Experience
- Work Experience within the Village
- Project Team
- Project Development Approach
- IDOT Prequalification
- Overall Completeness of Submittal

These evaluation factors may vary from one project to another depending on unique project requirements or conditions that may be present. In addition, any required Disadvantaged Business Enterprise (DBE) and local presence combined will not be more than 10%.

Scoring of Consultant Submittals: Each member of the selection committee will provide an independent score for each proposal using the form below prior to the selection committee meeting. For each consultant proposal, the scores will range from 0 (lowest in comparison to others) to 10 (highest in comparison to others) for each criterion, with the overall score



Village of Tinley Park, Illinois
 Qualification Based Selection (QBS) Policy and
 Procedures

March 2022

based on the weight assigned for each criterion.

Criteria	Weighting	Scores (0-10)		
		Consultant 1	Consultant 2..	Consultant X
<i>Project Understanding</i>	30%			
<i>Similar Project Experience</i>	20%			
<i>Work Experience within the Village</i>	10%			
<i>Project Team</i>	10%			
<i>Project Development Approach</i>	10%			
<i>IDOT Prequalification</i>	10%			
<i>Overall Completeness of Submittal</i>	10%			
Total Weighted Score	100%			

Final Scoring of Short-Listed Consultants: The selection committee member scores are averaged for an overall committee score which is used to establish a short list of three firms. The overall committee score for the short-listed firms is adjusted based on selection committee discussion, and any additional information gained from interviews of the short-listed firms, to determine the final scoping of the consultant submittals and the selected consultant. The VILLAGE reserves the right to waive the need for interviews if they are determined to be unnecessary due to the completeness of the received consultant submittals.

If less than three (3) consultant submittals are received, then the VILLAGE will request IDOT approval that the QBS procedures followed are acceptable, before proceeding with final scoring of consultant submittals received.

The final scoring of the consultant submittals, and the selected consultant will be presented to the VILLAGE Board for approval.

Suspension and Debarment: The VILLAGE will ensure the eligibility of the short-listed consultants before the final selection committee scores are prepared, by reviewing the System for Award Management (SAM) Exclusions website, IDOT's Chief Procurement Office's (CPO) website and the three other state CPO's websites for suspensions and/or debarment actions.

IV. Contract Negotiation

The VILLAGE will prepare an independent in-house estimate for the cost of the consultant engineering services being requested, prior to contract negotiation. The estimate is used in the negotiation.

The VILLAGE will require a two (2) person team to negotiate with the selected consultant. The VILLAGE negotiation team will consist of the Village Engineer and the Assistant Public



Village of Tinley Park, Illinois

Qualification Based Selection (QBS) Policy and Procedures

March 2022

Works Director; however, members of the negotiation team may delegate this responsibility to staff members. The negotiation team will review the contract costs and the indirect cost rates to assure they are compliant with Federal cost principles prior to submission to IDOT.

V. Project Administration

The Project Administrator (PA) for the VILLAGE will be the Village Engineer. The VILLAGE PA will monitor work on the project in accordance with the contract and provide status reports with the Mayor and Village Board as required and/or requested. The VILLAGE PA will prepare a written evaluation of the consultant's work at the end of each project. These reports are maintained in the VILLAGE consultant information database. The VILLAGE will follow IDOT's requirements, including the required submission of BLRS Form 05613 to the IDOT district at contract close-out along with the final invoice.

The VILLAGE PA will be required review and approve all invoices submitted by the consultant prior to payment and submission to IDOT for reimbursement.



Interoffice Memo

Date: March 28, 2022

To: Pat Carr, Village Manager

From: John Urbanski, Public Works Director

Subject: 1st Amendment to 175th Street Oak Park Ave. to Ridgeland Ave. CCDOTH Intergovernmental Agreement

Presented for April 5, 2022 COW & Village Board Agenda discussion and possible action:

Background:

On September 13, 2017, the Village of Tinley Park and Cook County Department of Transportation and Highway (CCDOTH) entered into an Intergovernmental Agreement (IGA), to establish the responsibilities and costs associated with Part A Preliminary Engineering Services and Part B Design Engineering Services for improvements along 175th Street from Oak Park Avenue to Ridgeland Avenue, Ridgeland Avenue from 175th Street to Oak Forest Avenue, and Oak Forest Avenue from Ridgeland Avenue to 167th Street.

Description:

In coordination with adjustments needed to be had during the design phase which has constituted this requested amendment for Subsection 3.1 of the original IGA:

- 3.1 County's Share of the PROJECT. The County shall pay for one hundred (100%) percent of the costs of the PROJECT as described in this Agreement, less the costs for the Village Work as described in Section 5.8 herein. The County's total estimated cost for the PROJECT is Five Hundred Thirty-Two Thousand Five Hundred Sixty and 00/100 Dollars (\$532,560.00).

This amendment still follows that costs associated with the details of the work as described for the "design Engineering" Phase will be 100% CCDOTH share as shown in the following table.

Budget / Finance:

ITEM	ESTIMATED TOTAL COST	VILLAGE SHARE	COUNTY SHARE
Original Agreement Part A Preliminary Engineering and Part B Design Engineering Costs September 13, 2017	\$482,562	\$0	\$482,562
First Amendment Additional Part B Design Engineering Costs	\$49,998	\$0	\$49,998
REVISED TOTAL	\$532,560	\$0	\$532,560

Staff Direction:

1. Approve amendment to IGA with Cook County and amendment to Resolution 2017-R-040.

Attachments:

1. First Amendment to Intergovernmental Agreement.
2. Original 2017-R-040 Resolution and IGA.



THE VILLAGE OF TINLEY PARK
Cook County, Illinois
Will County, Illinois

RESOLUTION
NO.2022-R-030

**A RESOLUTION APPROVING FIRST AMENDMENT TO AN
INTERGOVERNMENTAL AGREEMENT BETWEEN THE VILLAGE OF
TINLEY PARK AND COOK COUNTY, ILLINOIS BY AND THROUGH
THE DEPARTMENT OF TRANSPORTATION AND HIGHWAYS**

MICHAEL W. GLOTZ, PRESIDENT
NANCY O'CONNOR, VILLAGE CLERK

WILLIAM P. BRADY
WILLIAM A. BRENNAN
DIANE M. GALANTE
DENNIS P. MAHONEY
MICHAEL G. MUELLER
COLLEN M. SULLIVAN
Board of Trustees

Published in pamphlet form by authority of the President and Board of Trustees of the Village of Tinley Park
Peterson, Johnson, & Murray Chicago, LLC, Village Attorneys
200 W. Adams, Suite 2125, Chicago, IL 60606

VILLAGE OF TINLEY PARK

Cook County, Illinois

Will County, Illinois

RESOLUTION NO. 2022-R-030**A RESOLUTION APPROVING FIRST AMENDMENT TO AN INTERGOVERNMENTAL AGREEMENT BETWEEN THE VILLAGE OF TINLEY PARK AND COOK COUNTY, ILLINOIS BY AND THROUGH THE DEPARTMENT OF TRANSPORTATION AND HIGHWAYS**

WHEREAS, Section 6(a) of Article VII of the 1970 Constitution of the State of Illinois provides that any municipality which has a population of more than 25,000 is a home rule unit, and the Village of Tinley Park, Cook and Will Counties, Illinois, with a population in excess of 25,000 is, therefore, a home rule unit and, pursuant to the provisions of said Section 6(a) of Article VII, may exercise any power and perform any function pertaining to its government and affairs, including, but not limited to, the power to tax and to incur debt; and

WHEREAS, the Village of Tinley Park (“Village”) previously entered into an Intergovernmental Agreement (“Agreement”) on September 13, 2017 to establish the responsibilities and costs associated with improvements along 175th Street from Oak Park Avenue to Ridgeland Avenue, Ridgeland Avenue from 175th Street to Oak Forest Avenue, and Oak Forest Avenue from Ridgeland Avenue to 167th Street (the “Project”); and

WHEREAS, the Village desires to enter into an Amendment to the Agreement, attached hereto as Exhibit 1, with Cook County, Illinois by and through the Department of Transportation and Highways, to amend certain financial provisions; and

WHEREAS, the Corporate Authorities of the Village of Tinley Park, Cook and Will Counties, Illinois, have determined that it is in the best interest of said Village of Tinley Park and its residents to enter into said Agreement with Cook County, Illinois; and

NOW, THEREFORE, BE IT RESOLVED BY THE PRESIDENT AND BOARD OF TRUSTEES OF THE VILLAGE OF TINLEY PARK, COOK AND WILL COUNTIES, ILLINOIS, STATE AS FOLLOWS:

SECTION 1: The foregoing recitals shall be and are hereby incorporated as findings of fact as if said recitals were fully set forth herein.

SECTION 2: The President and Board of Trustees of the Village of Tinley Park hereby approve said Agreement substantially in the form, attached hereto as Exhibit 1, and made a part hereof, and the Village President and/or Village Manager are hereby authorized to execute and memorialize said Agreement, subject to review and revision as to form by the Village Attorney.

SECTION 3: Any policy, resolution, or ordinance of the Village that conflicts with the provisions of this Resolution shall be and is hereby repealed to the extent of such conflict.

SECTION 4: That the Village Clerk is hereby ordered and directed to publish this Resolution in pamphlet form, and this Resolution shall be in full force and effect from and after its passage, approval, and publication as required by law.

PASSED THIS 5th day of April, 2022.

AYES:

NAYS:

ABSENT:

APPROVED THIS 5th day of April, 2022.

VILLAGE PRESIDENT

ATTEST:

VILLAGE CLERK

STATE OF ILLINOIS)
 COUNTY OF COOK) SS
 COUNTY OF WILL)

CERTIFICATE

I, NANCY O’CONNOR, Village Clerk of the Village of Tinley Park, Counties of Cook and Will and State of Illinois, DO HEREBY CERTIFY that the foregoing is a true and correct copy of Resolution No. 2022-R-030, **“A RESOLUTION APPROVING FIRST AMENDMENT TO AN INTERGOVERNMENTAL AGREEMENT BETWEEN THE VILLAGE OF TINLEY PARK AND COOK COUNTY, ILLINOIS BY AND THROUGH THE DEPARTMENT OF TRANSPORTATION AND HIGHWAYS,”** which was adopted by the President and Board of Trustees of the Village of Tinley Park on the 5th day of April, 2022.

IN WITNESS WHEREOF, I have hereunto set my hand and affixed the corporate seal of the Village of Tinley Park this 5th day of April, 2022.

VILLAGE CLERK

FIRST AMENDMENT TO INTERGOVERNMENTAL AGREEMENT

COUNTY OF COOK

175TH STREET
Oak Park Avenue to Ridgeland AvenueRIDGELAND AVENUE
175th Street to Oak Forest AvenueOAK FOREST AVENUE
Ridgeland Avenue to 167th Street

VILLAGE OF TINLEY PARK

Section: 17-B6125-00-EG

This **First Amendment to Intergovernmental Agreement** (the "FIRST AMENDMENT") is entered into this ____ day of _____, 2022, by and between the COUNTY OF COOK, a body politic and corporate of the State of Illinois (the "COUNTY"), acting by and through its DEPARTMENT OF TRANSPORTATION AND HIGHWAYS (the "DEPARTMENT"), and the VILLAGE OF TINLEY PARK, a municipal corporation of the State of Illinois (the "VILLAGE"). The COUNTY and VILLAGE are sometimes referred to herein collectively as the "PARTIES."

RECITALS

WHEREAS, the COUNTY and VILLAGE entered into an Intergovernmental Agreement (the "AGREEMENT") on September 13, 2017, to establish the responsibilities and costs associated with Part A Preliminary Engineering Services and Part B Design Engineering Services for improvements along 175th Street from Oak Park Avenue to Ridgeland Avenue, Ridgeland Avenue from 175th Street to Oak Forest Avenue, and Oak Forest Avenue from Ridgeland Avenue to 167th Street (the "PROJECT");

WHEREAS, the AGREEMENT is incorporated herein as EXHIBIT 1;

WHEREAS, the PARTIES wish to amend certain financial provisions in the AGREEMENT as additional scope was identified for the PROJECT, including extended timelines for project management, right-of-way and utility coordination, and updates to the plans, specifications and estimates for final submittal to the COUNTY;

WHEREAS, the COUNTY, by virtue of its powers as set forth in the Counties Code, 55 ILCS 5/1-1 et seq., and the Illinois Highway Code, 605 ILCS 5/1-101 et seq., is authorized to enter into this FIRST AMENDMENT;

WHEREAS, the VILLAGE, by virtue of its powers as set forth in the Illinois Municipal Code, 65 ILCS 5/1-1-1 et seq., is authorized to enter into this FIRST AMENDMENT; and

WHEREAS, this FIRST AMENDMENT is further authorized under Article VII, Section 10 of the Illinois Constitution and by the provisions of the Intergovernmental Cooperation Act, 5 ILCS 220/1 et seq.

FIRST AMENDMENT TO INTERGOVERNMENTAL AGREEMENT
County of Cook/Village of Tinley Park
Section: 17-B6125-00-EG

NOW, THEREFORE, in consideration of the aforementioned recitals and the mutual covenants contained herein, the PARTIES agree as follows:

- A. All provisions contained in the original AGREEMENT that are not in conflict with the terms of this FIRST AMENDMENT shall remain in full force and effect.
- B. Subsection 3.1 of the AGREEMENT is hereby stricken and replaced with the following:
 - 3.1 County's Share of the PROJECT. The County shall pay for one hundred (100%) percent of the costs of the PROJECT as described in this Agreement, less the costs for the Village Work as described in Section 5.8 herein. The County's total estimated cost for the PROJECT is Five Hundred Thirty-Two Thousand Five Hundred Sixty and 00/100 Dollars (\$532,560.00).
- C. A Revised Funding Breakdown is incorporated into this FIRST AMENDMENT and the AGREEMENT and is attached hereto as REVISED EXHIBIT A. The Revised Funding Breakdown is only an estimate and does not limit the financial obligations of the PARTIES as described herein.
- D. In the event there is a conflict between the terms contained in this document and the attached exhibits, the terms included in this document shall control.
- E. This FIRST AMENDMENT shall become effective upon proper execution by authorized signatories of the PARTIES and shall remain in effect until the AGREEMENT is terminated by both PARTIES in writing.
- F. This FIRST AMENDMENT may be executed in two (2) or more counterparts, each of which shall be deemed an original and all of which shall be deemed one and the same instrument.
- G. This FIRST AMENDMENT shall be binding upon and inure to the benefit of the PARTIES hereto and their respective successors and assigns.
- H. The introductory recitals included at the beginning of this FIRST AMENDMENT are agreed to and incorporated into this FIRST AMENDMENT.

THE REMAINDER OF THIS PAGE IS INTENTIONALLY BLANK

FIRST AMENDMENT TO INTERGOVERNMENTAL AGREEMENT
County of Cook/Village of Tinley Park
Section: 17-B6125-00-EG

IN WITNESS WHEREOF, the COUNTY and the VILLAGE have caused this FIRST AMENDMENT to be executed by their respective officials on the dates shown.

EXECUTED BY COUNTY OF COUNTY:

EXECUTED BY VILLAGE OF TINLEY PARK:

Toni Preckwinkle
President
Cook County Board of Commissioners

Michael W. Glotz
Mayor

This ___ day of _____ A.D. 2022.

This ___ day of _____ A.D. 2022.

ATTEST: _____
County Clerk

ATTEST: _____
Village Clerk

(SEAL)

(SEAL)

RECOMMENDED BY:

APPROVED AS TO FORM:
Kimberly M. Foxx, State's Attorney

Jennifer "Sis" Killen, P.E., PTOE
Superintendent
County of Cook
Department of Transportation and Highways

Assistant State's Attorney

FIRST AMENDMENT TO INTERGOVERNMENTAL AGREEMENT
 County of Cook/Village of Tinley Park
 Section: 17-B6125-00-EG

REVISED EXHIBIT A

Funding Breakdown

ITEM	ESTIMATED TOTAL COST	VILLAGE SHARE	COUNTY SHARE
Original Agreement Part A Preliminary Engineering and Part B Design Engineering Costs September 13, 2017	\$482,562	\$0	\$482,562
First Amendment Additional Part B Design Engineering Costs	\$49,998	\$0	\$49,998
REVISED TOTAL	\$532,560	\$0	\$532,560

STATE OF ILLINOIS)
COUNTY OF COOK) SS.
COUNTY OF WILL)

CLERK'S CERTIFICATE

I, **KRISTIN A. THIRION**, the duly elected and qualified Village Clerk of the Village of Tinley Park, Cook and Will Counties, Illinois, do hereby certify that attached hereto is a true and correct copy of the Resolution now on file in my office, entitled:

RESOLUTION NO. 2017-R-040

A RESOLUTION AUTHORIZING THE EXECUTION OF AN INTERGOVERNMENTAL AGREEMENT BETWEEN THE VILLAGE OF TINLEY PARK AND THE COUNTY OF COOK FOR 175TH STREET – OAK PARK AVENUE TO RIDGELAND AVENUE

which was passed by the Board of Trustees of the Village of Tinley Park at a regular meeting held on the 1st day of August, 2017, at which meeting a quorum was present, and approved by the President of the Village of Tinley Park on the 1st day of August, 2017.

I further certify that the vote on the question of the passage of the said Resolution by the Board of Trustees of the Village of Tinley Park was taken by the Ayes and Nays and recorded in the Journal of Proceedings of the Board of Trustees of the Village of Tinley Park, and that the result of said vote was as follows, to-wit:

- AYES:** Younker, Pannitto, Berg, Brady, Glotz, Mangin
- NAYS:** None
- ABSENT:** None

I do further certify that the original Resolution, of which the attached is a true copy, is entrusted to my care for safekeeping, and that I am the lawful keeper of the same.

IN WITNESS WHEREOF, I have hereunto set my hand and affixed the seal of the Village of Tinley Park, this 9 day of August, 2017



Kristin A. Thirion
 Village Clerk

RESOLUTION NO. 2017-R-040**A RESOLUTION AUTHORIZING THE EXECUTION OF AN INTERGOVERNMENTAL AGREEMENT BETWEEN THE VILLAGE OF TINLEY PARK AND THE COUNTY OF COOK FOR 175TH STREET – OAK PARK AVENUE TO RIDGELAND AVENUE**

WHEREAS, the Village of Tinley Park, Cook and Will Counties, Illinois, is a Home Rule Unit pursuant to the Illinois Constitution of 1970; and

WHEREAS, the Corporate Authorities of the Village of Tinley Park, Cook and Will Counties, Illinois, have considered entering into An Intergovernmental Agreement with the County of Cook pertaining to the making of improvements along 175th, Ridgeland Avenue, and Oak Forest Avenue, a true and correct copy of such Intergovernmental Agreement being attached hereto and made a part hereof as **EXHIBIT 1**; and

WHEREAS, the Corporate Authorities of the Village of Tinley Park, Cook and Will Counties, Illinois, have determined that it is in the best interests of said Village of Tinley Park that said Agreement be entered into by the Village of Tinley Park;

NOW, THEREFORE, Be It Resolved by the President and Board of Trustees of the Village of Tinley Park, Cook and Will Counties, Illinois, as follows:

Section 1: The Preambles hereto are hereby made a part of, and operative provisions of, this Resolution as fully as if completely repeated at length herein.

Section 2: That this President and Board of Trustees of the Village of Tinley Park hereby find that it is in the best interests of the Village of Tinley Park and its residents that the aforesaid Intergovernmental Agreement be entered into and executed by said Village of Tinley Park, with said Agreement to be substantially in the form attached hereto and made a part hereof as **EXHIBIT 1**.

Section 3: That the President and Clerk of the Village of Tinley Park, Cook and Will Counties, Illinois are hereby authorized to execute for and on behalf of said Village of Tinley Park the aforesaid Intergovernmental Agreement.

Section 4: That this Resolution shall take effect from and after its adoption and approval.

ADOPTED this 1st day of August, 2017, by the Corporate Authorities of the Village of Tinley Park
on a roll call vote as follows:

AYES:

NAYS:

ABSENT:

APPROVED this 1st day of August, 2017, by the President of the Village of Tinley Park.

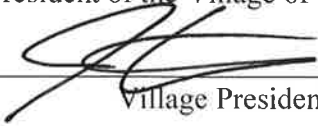

Village President

ATTEST:



Deputy Village Clerk

EXHIBIT 1

**AN INTERGOVERNMENTAL AGREEMENT BETWEEN THE VILLAGE OF TINLEY PARK
AND THE COUNTY OF COOK FOR 175TH STREET –
OAK PARK AVENUE TO RIDGELAND AVENUE**

INTERGOVERNMENTAL AGREEMENT

THE COUNTY OF COOK

175TH STREET

Oak Park Avenue to Ridgeland Avenue

VILLAGE OF TINLEY PARK

RIDGELAND AVENUE

175th Street to Oak Forest Avenue

OAK FOREST AVENUE

Ridgeland Avenue to 167th Street

Section: 17-B6125-00-EG

This **Intergovernmental Agreement** (the "Agreement") is made and entered into by and between the County of Cook (the "County"), a body politic and corporate of the State of Illinois, and the Village of Tinley Park (the "Village"), a municipal corporation of the State of Illinois. The County and the Village are sometimes individually referred to as "Party" and collectively referred to as the "Parties."

RECITALS

WHEREAS, the Constitution of the State of Illinois, 1970, Article VII, Section 10, authorizes units of local government to contract or otherwise associate among themselves in any manner not prohibited by law or ordinance; and

WHEREAS, the provisions of the Intergovernmental Cooperation Act, 5 ILCS 220/1 *et seq.*, authorize and encourages intergovernmental cooperation; and

WHEREAS, the County by virtue of its powers as set forth in the Counties Code, 55 ILCS 5/1-1 *et seq.*, and the Illinois Highway Code, 605 ILCS 5/1-101 *et seq.*, is authorized to enter into this Agreement; and

WHEREAS, the Village by virtue of its powers as set forth in the Illinois Municipal Code, 65 ILCS 5/1-1-1 *et seq.*, is authorized to enter into this Agreement; and

WHEREAS, the County and the Village are units of local government under the Illinois and have the constitutional and statutory authority to enter into this Agreement; and

WHEREAS, in order to facilitate the free flow of traffic and ensure the safety of the motoring public, the County and the Village wish to make improvements along 175TH Street from Oak Park Avenue to Ridgeland Avenue, Ridgeland Avenue from 175th Street to Oak Forest Avenue, and Oak Forest Avenue from Ridgeland Avenue to 167th Street; and

WHEREAS, the Village has prepared Part A Preliminary Engineering Study report originally approved in April 2009 for the 175th Street corridor from Oak Park Avenue to Ridgeland Avenue, Ridgeland Avenue corridor from 175th Street to Oak Forest Avenue and Oak Forest Avenue corridor from Ridgeland Avenue to 167th Street; and

175TH STREET
RIDGELAND AVENUE
OAK FOREST AVENUE
Section: 17-B6125-00-EG

WHEREAS, the planned improvements include update of the Part A Preliminary Engineering Study report, and completing Part B Design Engineering for the improvement along 175th Street from Oak Park Avenue to Ridgeland Avenue, Ridgeland Avenue from 175th Street to Oak Forest Avenue and Oak Forest Avenue from Ridgeland Avenue to 167th Street (hereinafter the planned improvements are collectively referred to as the "PROJECT") and said PROJECT is herein designated as County Section: 17-B6125-00-EG; and

WHEREAS, the Village and County established terms for updating Part A Preliminary Engineering Study report and completion of Part B Design Engineering for the PROJECT in a Letter of Understanding dated June 15, 2016 and accepted by the Village on July 19, 2016; and

WHEREAS, the Part A Preliminary Engineering Study report updates for the improvement will include general administration, meetings with various agencies, revisions to preliminary design and drainage study, public involvement, existing right-of-way determination and right-of-way impact analysis, traffic signal warrant study, and all other related work necessary to complete the revised Part A project report to current standards and requirements; and

WHEREAS, the Part B Design Engineering for the improvement will include general administration, coordination with various agencies, municipalities and utility companies; preparation of right-of-way plans and documents, plats and legals, public involvement, preparation of pre-final and final construction plans, specifications, estimates and contract documents; project administration, coordination with regulatory agencies and permit acquisition, field services, construction assistance, shop drawing review and various meetings; and

WHEREAS, the Part A Preliminary Engineering Study was originally conducted by the Village's consultant, Robinson Engineering, Ltd., it is in the mutual best interest of the Parties hereto for Robinson Engineering, Ltd. to conduct Part A Engineering Study updates and Part B Design Engineering for the PROJECT by utilizing its extensive knowledge and understanding of the improvements in order to most effectively accomplish labor and cost efficiencies; and

WHEREAS, the County has requested assistance from the Village with conducting the Part A Preliminary Engineering update services and Part B Design Engineering services for the PROJECT and the Village concurs with this request; and

WHEREAS, the County and the Village, by this instrument, desire to memorialize their respective obligations and responsibilities toward the PROJECT; and

NOW THEREFORE, in consideration of the promises, covenants, terms and conditions set forth in this Agreement, the Parties hereto agree as follows:

SECTION 1. INCORPORATION OF RECITALS

The above recitals are incorporated into this Agreement as if set forth herein.

SECTION 2. TERM AND TERMINATION

This Agreement between the County and the Village shall not become effective unless authorized and executed by the Cook County Board of Commissioners and an authorized representative of the Village. This Agreement is a legal, valid and binding agreement, enforceable against the Village and, the County, in accordance with its terms. This Agreement shall terminate two years after completion of the PROJECT.

175TH STREET
RIDGELAND AVENUE
OAK FOREST AVENUE
Section: 17-B6125-00-EG

SECTION 3. PROJECT FUNDS

- 3.1 County's Share of the PROJECT. The County shall pay for one hundred (100%) percent of the costs of the PROJECT as described in this Agreement, less the costs for the Village Work as described in Section 5.8 herein. The County's total estimated cost for the PROJECT is Four Hundred Eighty-Two Thousand Five Hundred Sixty-Two and 00/100 Dollars (\$482,562.00).
- 3.2 Village's Share of the PROJECT. Except for costs related to Village authorized work that is outside the PROJECT scope of work and subject to the availability of County Funding, the Village shall not incur any costs for the PROJECT.
- 3.3 Cost Estimates. The Village Share and the County Share are more fully described in the Funding Breakdown which is incorporated and attached hereto as Exhibit A and is only an estimate. Notwithstanding the forgoing, the County's obligations to pay for eligible items shall be based upon the actual work performed and the costs as approved for the PROJECT.

SECTION 4. COUNTY'S RESPONSIBILITIES

- 4.1 Contract Review. The County shall review the Part A Preliminary Engineering update Services contract and Part B Design Engineering Services contract for adequacy and acknowledge its concurrence for same to the Village.
- 4.2 Plan Review. The County shall review and approve plan submittals in a timely manner.
- 4.3 Right-of-Way.
- 4.3.1 The County shall review and approve the Village's plats and legal descriptions.
- 4.3.2 The County shall responsible for preparation of appraisals, review of appraisals and perform negotiations for land acquisition.
- 4.3.3 The County shall pay for one hundred (100%) percent of the costs for the preparation of appraisals, review appraisals, negotiations and land acquisition.
- 4.4 Payments to the Village. The costs that the County is obligated to pay as described in Section 3. Project Funds, shall be paid on a progressive basis as follows:
- 4.4.1 The first installment in the amount of Seventy-Eight Thousand Nine Hundred Sixty-Six Dollars (\$78,966.00), shall be invoiced by the Village within ninety (90) days following County execution of this Agreement and the County shall pay the Village within ninety (90) days after receipt of invoice from the Village.
- 4.4.2 The remaining balance of County obligations shall be invoiced by the Village on a progressive basis thereafter and the County shall pay the Village within ninety (90) days after receipt of the invoice from the Village.

175TH STREET
RIDGELAND AVENUE
OAK FOREST AVENUE
Section: 17-B6125-00-EG

SECTION 5. VILLAGE'S OBLIGATIONS

- 5.1 Village as Lead Agent; Appropriation of Funds. The Village will act as Lead Agent for the engineering phases of the PROJECT and shall finance the Part A preliminary engineering study update and Part B design engineering costs, subject to the reimbursements provisions found in Section 3.
- 5.2 Design Engineering. The Village shall execute an engineering services contract with Robinson Engineering, Ltd., subject to contract review and approval by the County, to conduct Part A Engineering Study updates, Part B Design Engineering and prepare PROJECT construction design plans, specifications, estimates and contract documents for bidding purposes and obtain County and State of Illinois approval of final plans, specifications, estimates and contract documents.
- 5.3 Right-of-way. The Village's consultant shall include surveying to reference highway centerlines to public landlines, preparation of legal descriptions, land surveying to locate boundaries, staking of proposed right-of-way, preparation of a statutory plat of highways (including cover sheet), preparation and recording of monument record documents for all U.S. public and survey monuments referred to in the legal descriptions.
- 5.4 Plan Development. The Village shall have the County participate in plan development and review of plan submittals by the Village consultant (at 65%, 90% and 100% levels) and await County approval of Final Plans before advertising the PROJECT for letting. The submittal shall be directed to the Bureau Chief of Design, Department of Transportation and Highways, 69 W. Washington Street, 23rd Floor, Chicago, IL 60602.
- 5.5 Regulatory Permits. The Village shall prepare, submit the required documentation (including any associated fees) for and secure any regulatory permits required for the PROJECT.
- 5.6 Meetings and Coordination. The Village will coordinate with the County for identification and scheduling of all meetings for the PROJECT, including utility coordination, staging, review meetings and public meetings, adjacent municipalities and regulatory agencies, as required.
- 5.7 County's Identifier. The Village shall reference all correspondence, invoices and other documents for the PROJECT with the County's identifier Section: 17-B6125-00-EG.
- 5.8 Village Work: The Village shall pay for one hundred (100%) percent of the costs for design engineering, construction, construction engineering preparation of appraisals, review appraisals, negotiations, land acquisition and regulatory permit approvals for any Village infrastructure or infrastructure adjustments that may be identified during the Part A Study and/or Part B design engineering and, said work to include new water main and sanitary sewer.
- 5.9 Street Lighting: The Village shall pay for one hundred (100%) percent of the costs for construction and construction engineering for Street Lighting. The County shall pay for one hundred (100%) percent of the costs for design engineering for Street Lighting.
- 5.10 Final Plans. The Village shall supply the County with Final PROJECT plans, specifications and contract documents for bidding purposes.

175TH STREET
RIDGELAND AVENUE
OAK FOREST AVENUE
Section: 17-B6125-00-EG

SECTION 6. GENERAL PROVISIONS

- 6.1 Governing Law and Venue. This Agreement shall be interpreted under, and governed by, the laws of the State of Illinois, without regard to conflict-of-law principles. Any claim, suit, action, or proceeding brought in connection with this Agreement shall be in the Circuit Court of Cook County and each Party hereby irrevocably consents to the personal and subject matter jurisdiction of such court and waives any claim that such court does not constitute a convenient and appropriate venue for such claims, suits, actions, or proceedings.
- 6.2 Default. The Village shall be in default hereunder in the event of a material breach by the Village of any term or condition of this Agreement including, but not limited to, a representation or warranty, where the Village has failed to cure such breach within ninety (90) days after written notice of the breach is given to Village by the County, setting forth the nature of such breach. Failure of County to give written notice of breach to the Village shall not be deemed to be a waiver of the County's right to assert such breach at a later time. Upon default by the Village, the County shall be entitled to exercise all available remedies at law or in equity, including, but not limited to, termination of this Agreement upon thirty (30) days' written notice to the Village.
- The County shall be in default hereunder in the event of a material breach by the County of any term or condition of this Agreement including, but not limited to, a representation or warranty, where the County has failed to cure such breach within ninety (90) days after written notice of the breach is given to the County by the Village, setting forth the nature of such breach. Failure of Village to give written notice of breach to the County shall not be deemed to be a waiver of the Village's right to assert such breach at a later time. Upon default by the County, the Village shall be entitled to exercise all available remedies at law or in equity, including, but not limited to, termination of this Agreement upon thirty (30) days' written notice to the County.
- 6.3 Modification. This Agreement may not be altered, modified or amended except by a written instrument signed by both Parties; provided, however, the Parties agree that provisions required to be inserted in this Agreement by laws, ordinances, rules, regulations or executive orders are deemed inserted whether or not they appear in this Agreement and that in no event will the failure to insert such provisions prevent the enforcement of this Agreement.
- 6.4 Binding Successors. The Parties agree that their respective successors and assigns shall be bound by the terms of this Agreement.
- 6.5 Compliance with Department of Transportation and Highways Permits. This Agreement shall serve in lieu of a separate County permit for the water main, sanitary sewer, storm sewer, sidewalks, bike path and street lighting installed as part of the Project; and, by execution of this Agreement, the Village shall be bound by the General Terms for Department of Transportation and Highways Permits as they exist on the date of the execution of this Agreement by the County.
- 6.6 Force Majeure. Neither the County nor the Village shall be liable for failing to fulfill any obligation under this Agreement to the extent any such failure is caused by any event beyond such Party's control and which event is not caused by such Party's fault or negligence. Such events shall include, but are not limited to, acts of God, acts of war, fires, lightning, floods, epidemics or riots.
- 6.7 Time of the Essence. The obligations of the Parties as set forth in this Agreement shall be performed in a timely manner such that it will not result in a delay of the Project timetable as determined by the Parties.

175TH STREET
RIDGELAND AVENUE
OAK FOREST AVENUE
Section: 17-B6125-00-EG

- 6.8 Notices. Unless otherwise specified, any notice, demand or request required under this Agreement must be given in writing at the addresses set forth below by any of the following means: personal service, overnight courier or first class mail.

TO THE COUNTY:

Mr. John Yonan, P.E.
Superintendent
Cook County Department of Transportation and Highways
69 West Washington, Suite 2400
Chicago, IL 60602

TO THE VILLAGE OF TINLEY PARK:

Mr. David Niemeyer
Village Manager
Village of Tinley Park
16250 South Park Avenue
Tinley Park, IL 60477

- 6.9 Entire Agreement. This Agreement constitutes the entire agreement between the County and the Village, and merges all discussion between them and supersedes and replaces any and every other prior or contemporaneous agreement, negotiation, understanding, commitment and writing with respect to such subject matter hereof.

THE REMAINDER OF THIS PAGE IS INTENTIONALLY BLANK

175TH STREET
RIDGELAND AVENUE
OAK FOREST AVENUE
Section: 17-B6125-00-EG

IN WITNESS WHEREOF, the County and the Village have caused this Agreement to be executed by their respective officials on the dates as shown.

EXECUTED BY COUNTY:

EXECUTED BY
VILLAGE OF TINLEY PARK:

Toni Preckwinkle
President
Cook County Board of Commissioners

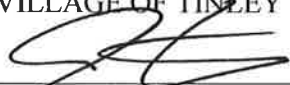

Jacob C. Vandenberg
Village President

This ____ day of _____ A.D. 2017.

This 1 day of August A.D. 2017.

ATTEST: _____
County Clerk

(SEAL)

ATTEST: 

Deputy Village Clerk

(SEAL)

RECOMMENDED BY:

APPROVED AS TO FORM:
Kimberly M. Foxx, State's Attorney

John Yonan, P.E.
Superintendent
County of Cook
Department of Transportation and Highways

Assistant State's Attorney

175TH STREET
RIDGELAND AVENUE
OAK FOREST AVENUE
Section: 17-B6125-00-EG

IN WITNESS WHEREOF, the County and the Village have caused this Agreement to be executed by their respective officials on the dates as shown.

EXECUTED BY COUNTY:

EXECUTED BY
VILLAGE OF TINLEY PARK:

Toni Preckwinkle

Jacob C. Vandenberg

Toni Preckwinkle
President
Cook County Board of Commissioners

Jacob C. Vandenberg
Village President

This 13th day of SEPT. A.D. 2017.

This 1 day of August A.D. 2017.

ATTEST: *David Orr*

ATTEST: *Russell J. Gossett*

County Clerk

Deputy Village Clerk

(SEAL)

APPROVED BY THE BOARD OF
COOK COUNTY COMMISSIONERS

SEP 13 2017

COM _____



RECOMMENDED BY:

APPROVED AND FORWARDED
Kimberly M. Fox, State's Attorney

John Yonan

Kimberly M. Fox

John Yonan, P.E.
Superintendent
County of Cook
Department of Transportation and Highways

Assistant State's Attorney

I, DAVID D. ORR, County Clerk of Cook County, in the State of Illinois aforesaid and keeper of the records and files of said Cook County, do hereby certify that The Board of Commissioners of The County of Cook, at their regular meeting held on September 13, 2017, passed the following Resolution:

17-R-

RESOLUTION

Sponsored by

THE HONORABLE TONI PRECKWINKLE

PRESIDENT OF THE COOK COUNTY BOARD OF COMMISSIONERS

RESOLVED, by the members of The Board of Commissioners of Cook County, Illinois, on behalf of the County of Cook, to authorize and direct its President to execute, by original signature or authorized signature stamp, two (2) copies of an Intergovernmental Agreement with the Village of Tinley Park, attached, wherein the Village will be the lead agency for Part A preliminary engineering study update and Part B design engineering services for improvements along 175th Street from Oak Park Avenue to Ridgeland Avenue, Ridgeland Avenue from 175th Street to Oak Forest Avenue and Oak Forest Avenue from Ridgeland Avenue to 167th Street; that the County of Cook will pay for a share of the Part A preliminary engineering study update and Part B design engineering services costs incurred by the Village and shall reimburse the Village of Tinley Park for its share of said costs (estimated total County share \$482,562.00) under County Section: 17-B6125-00-ES; and, the Department of Transportation and Highways is authorized and directed to return one (1) executed copy of the Agreement with a certified copy of this Resolution to the Village of Tinley Park and implement the terms of the Agreement.

All of which appears from the records and files of my office.

APPROVED BY THE BOARD OF
COOK COUNTY COMMISSIONERS

SEP 13 2017

COM _____

(SEAL)

IN WITNESS WHEREOF I have hereunto set my hand and affixed the SEAL of said County at my office in the City of Chicago, in said County, this 13th day of September A.D. 2017.

David Orr

County Clerk

175TH STREET
 RIDGELAND AVENUE
 OAK FOREST AVENUE
 Section: 17-B6125-00-EG

EXHIBIT A

Funding Breakdown

ITEM	ESTIMATED TOTAL COST	VILLAGE SHARE	COUNTY SHARE
Part A Preliminary Engineering update Services	\$78,966.00	\$0	\$78,966.00
Part B Design Engineering Services	\$403,596.00	\$0	\$403,596.00
TOTAL	\$482,562.00	\$0	\$482,562.00



Interoffice Memo

Date: March 30, 2022
To: John Urbanski, Public Works Director
From: Kelly Mulqueeny, Street Superintendent
Subject: Stormwater Area Maintenance FY 2023 -Service Contract Award (Year 1 of 3)

Presented at the Committee of the Whole and Village Board Meetings for consideration and possible action:

Scope of Work: This requested service contract is for a qualified contractor to provide maintenance for stormwater areas including installation, management, and stewardship for naturalized areas at various locations throughout the Village.

Background: This RFP was advertised on March 1, 2022 in accordance with state bidding laws; two (2) sealed proposals were received by the deadline on March 21, 2022, at noon, and recorded by the Village Clerk's office.

Cardno, now Stantec	Monee, IL	\$124,417.40
Davey Resource Group	Elmhurst, IL	\$136,624.24

Description: Public Works is recommending that we approve a contract to Cardno, now Stantec who rated very high on the RFP scoring and has proven on previous contracts to be a professional, reliable contractor with reasonable rates. The contract has the option of 2 (two) – 1 (one) year renewals. This would be the first year of the contract.

Budget / Finance: Funding in the amount of \$189,500 will be available in the FY23 Budget; Storm Water Mangement.

Budget Available	\$228,000
Costs Stormwater Area Maintenance	<u>\$228,000</u>
Difference	\$0

Staff Direction Request:

1. Approve the service contract for the FY23 stormwater maintenance contract with Cardno, now Stantec in the amount of \$228,000.
2. Direct Staff as necessary.



THE VILLAGE OF TINLEY PARK
Cook County, Illinois
Will County, Illinois

RESOLUTION
NO. 2022-R-031

**A RESOLUTION APPROVING A CONTRACT BETWEEN THE VILLAGE OF TINLEY
PARK AND CARDNO, NOW STANTEC, FOR STORMWATER AREA MAINTENANCE - FY
2023-SERVICE CONTRACT (YEAR 1 OF 3)**

MICHAEL W. GLOTZ, PRESIDENT
NANCY M. O'CONNOR, VILLAGE CLERK

WILLIAM P. BRADY
WILLIAM A. BRENNAN
DIANE M. GALANTE
DENNIS P. MAHONEY
MICHAEL G. MUELLER
COLLEEN M. SULLIVAN
Board of Trustees

RESOLUTION NO. 2022-R-031**A RESOLUTION APPROVING A CONTRACT BETWEEN THE VILLAGE OF TINLEY PARK AND CARDNO, NOW STANTEC, FOR STORMWATER AREA MAINTENANCE FY 2023-SERVICE CONTRACT (YEAR 1 OF 3)**

WHEREAS, the Village of Tinley Park, Cook and Will Counties, Illinois, is a Home Rule Unit pursuant to the Illinois Constitution of 1970; and

WHEREAS, the Corporate Authorities of the Village of Tinley Park, Cook and Will Counties, Illinois, have considered entering into a Contract with Cardno, now Stanec, a true and correct copy of such Contract being attached hereto and made a part hereof as **EXHIBIT 1**; and

WHEREAS, the Corporate Authorities of the Village of Tinley Park, Cook and Will Counties, Illinois, have determined that it is in the best interests of said Village of Tinley Park that said Contract be entered into by the Village of Tinley Park;

NOW, THEREFORE, Be It Resolved by the President and Board of Trustees of the Village of Tinley Park, Cook and Will Counties, Illinois, as follows:

Section 1: The Preambles hereto are hereby made a part of, and operative provisions of, this Resolution as fully as if completely repeated at length herein.

Section 2: That this President and Board of Trustees of the Village of Tinley Park hereby find that it is in the best interests of the Village of Tinley Park and its residents that the aforesaid "Contract" be entered into and executed by said Village of Tinley Park, with said Contract to be substantially in the form attached hereto and made a part hereof as **EXHIBIT 1**.

Section 3: That the President and Clerk of the Village of Tinley Park, Cook and Will Counties, Illinois are hereby authorized to execute for and on behalf of said Village of Tinley Park the aforesaid Contract.

Section 4: That this Resolution shall take effect from and after its adoption and approval.

ADOPTED this 5th day of April, 2022, by the Corporate Authorities of the Village of Tinley Park on a roll call vote as follows:

AYES:

NAYS:

ABSENT:

APPROVED this 5th day of April, 2022, by the President of the Village of Tinley Park.

Village President

ATTEST:

Village Clerk

EXHIBIT 1

CONTRACT BETWEEN THE VILLAGE OF TINLEY PARK AND CARDNO, NOW STANTEC, FOR STORMWATER AREA MAINTENANCE FY 2023- SERVICE CONTRACT (YEAR 1 OF 3)

STATE OF ILLINOIS)
COUNTY OF COOK) SS
COUNTY OF WILL)

CERTIFICATE

I, NANCY M. O’CONNOR, Village Clerk of the Village of Tinley Park, Counties of Cook and Will and State of Illinois, DO HEREBY CERTIFY that the foregoing is a true and correct copy of Resolution No. 2022-R-031, “**A RESOLUTION APPROVING A CONTRACT BETWEEN THE VILLAGE OF TINLEY PARK AND CARDNO, NOW STANTEC, FOR STORMWATER AREA MAINTENANCE FY 2023-SERVICE CONTRACT (YEAR 1 OF 3)**,” which was adopted by the President and Board of Trustees of the Village of Tinley Park on April 5, 2022.

IN WITNESS WHEREOF, I have hereunto set my hand and affixed the corporate seal of the Village of Tinley Park this 5th day of April, 2022.

VILLAGE CLERK



Interoffice Memo

Date: March 29, 2022

To: John Urbanski, Public Works Director

From: Kelly Mulqueeney, Street Superintendent

Subject: Landscape Bed Maintenance – Service Contract Award (Year 1 of 3)

Presented for at the Committee of the Whole and Village Board meetings for consideration and possible action:

Scope of Work: This requested service contract is for a qualified contractor to provide maintenance to the Villages 5.6 acres of landscape beds throughout Tinley Park.

Background: This RFP was advertised on March 1, 2022 in accordance with state bidding laws; three (3) sealed proposals were received by the deadline on March 22, 2022, at noon, and recorded by the Village Clerk's office.

City Escape Garden and Design, LLC	Chicago, IL	\$153,089.46
Christy Webber Landscapes	Chicago, IL	\$159,797.75
Semmer Landscape	Chicago, IL	\$299,531.00

Description:

Public Works is recommending that we approve a contract to City Escape Garden and Design, LLC who rated very high on the scoring for Landscape Bed Maintenance. The contract has the option of 2 (two) – 1 (one) year renewals. This would be the first year out of the possible 3 (three) year contract.

Budget / Finance: Funding is budgeted in the FY23 Budget.

Budget Available	\$160,000.00
Year 1 of 3 contract	<u>\$153,089.46</u>
Difference under budget	\$ 6,910.54

Staff Direction Request:

1. Approve the service contract for the FY2023 Contract with City Escape Garden and Design, LLC of Chicago, IL in the amount of \$153,089.46
2. Direct Staff as necessary.

THE VILLAGE OF TINLEY PARK
Cook County, Illinois
Will County, Illinois

RESOLUTION
NO. 2022-R-032

**A RESOLUTION APPROVING A CONTRACT BETWEEN THE VILLAGE OF TINLEY
PARK AND CITY ESCAPE GARDEN AND DESIGN, LLC FOR LANDSCAPE BED
MAINTENANCE SERVICE CONTRACT (YEAR 1 OF 3)**

MICHAEL W. GLOTZ, PRESIDENT
NANCY M. O'CONNOR, VILLAGE CLERK

WILLIAM P. BRADY
WILLIAM A. BRENNAN
DIANE M. GALANTE
DENNIS P. MAHONEY
MICHAEL G. MUELLER
COLLEEN M. SULLIVAN
Board of Trustees

RESOLUTION NO. 2022-R-032**A RESOLUTION APPROVING A CONTRACT BETWEEN THE VILLAGE OF TINLEY PARK AND CITY ESCAPE GARDEN AND DESIGN, LLC FOR LANDSCAPE BED MAINTENANCE SERVICE CONTRACT (YEAR 1 OF 3)**

WHEREAS, the Village of Tinley Park, Cook and Will Counties, Illinois, is a Home Rule Unit pursuant to the Illinois Constitution of 1970; and

WHEREAS, the Corporate Authorities of the Village of Tinley Park, Cook and Will Counties, Illinois, have considered entering into a Contract with City Escape Garden and Design, LLC, a true and correct copy of such Contract being attached hereto and made a part hereof as **EXHIBIT 1**; and

WHEREAS, the Corporate Authorities of the Village of Tinley Park, Cook and Will Counties, Illinois, have determined that it is in the best interests of said Village of Tinley Park that said Contract be entered into by the Village of Tinley Park;

NOW, THEREFORE, Be It Resolved by the President and Board of Trustees of the Village of Tinley Park, Cook and Will Counties, Illinois, as follows:

Section 1: The Preambles hereto are hereby made a part of, and operative provisions of, this Resolution as fully as if completely repeated at length herein.

Section 2: That this President and Board of Trustees of the Village of Tinley Park hereby find that it is in the best interests of the Village of Tinley Park and its residents that the aforesaid "Contract" be entered into and executed by said Village of Tinley Park, with said Contract to be substantially in the form attached hereto and made a part hereof as **EXHIBIT 1**.

Section 3: That the President and Clerk of the Village of Tinley Park, Cook and Will Counties, Illinois are hereby authorized to execute for and on behalf of said Village of Tinley Park the aforesaid Contract.

Section 4: That this Resolution shall take effect from and after its adoption and approval.

ADOPTED this 5th day of April, 2022, by the Corporate Authorities of the Village of Tinley Park on a roll call vote as follows:

AYES:

NAYS:

ABSENT:

APPROVED this 5th day of April, 2022, by the President of the Village of Tinley Park.

Village President

ATTEST:

Village Clerk

EXHIBIT 1

**APPROVING A CONTRACT BETWEEN THE VILLAGE OF TINLEY PARK AND CITY
ESCAPE GARDEN AND DESIGN, LLC FOR LANDSCAPE BED MAINTENANCE SERVICE
CONTRACT (YEAR 1 OF 3)**

STATE OF ILLINOIS)
COUNTY OF COOK) SS
COUNTY OF WILL)

CERTIFICATE

I, NANCY M. O’CONNOR, Village Clerk of the Village of Tinley Park, Counties of Cook and Will and State of Illinois, DO HEREBY CERTIFY that the foregoing is a true and correct copy of Resolution No. 2022-R-032, **“A RESOLUTION APPROVING A CONTRACT BETWEEN THE VILLAGE OF TINLEY PARK AND CITY ESCAPE GARDEN AND DESIGN, LLC FOR LANDSCAPE BED MAINTENANCE SERVICE CONTRACT (YEAR 1 OF 3),”** which was adopted by the President and Board of Trustees of the Village of Tinley Park on April 5, 2022.

IN WITNESS WHEREOF, I have hereunto set my hand and affixed the corporate seal of the Village of Tinley Park this 5th day of April, 2022.

VILLAGE CLERK

STAFF COMMENT

BOARD COMMENT

PUBLIC COMMENT